

# CARDIFF

132121/  
726-23-1453

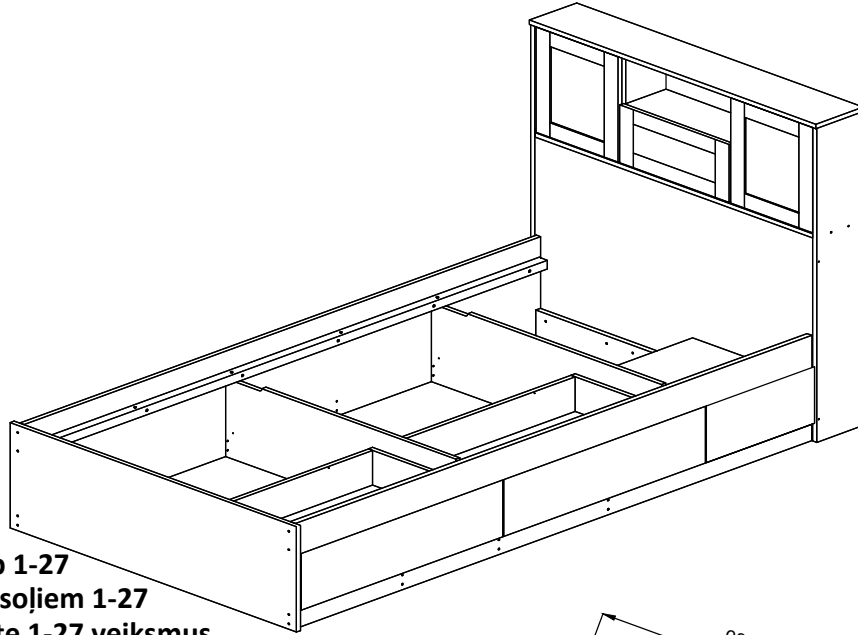

EN : Use Step 1-27  
LV : Sekojiet soļiem 1-27  
LT : Naudokite 1-27 veiksmus  
EE : Kasutage sammu 1-27  
RU : Выполняйте шаги 1-27

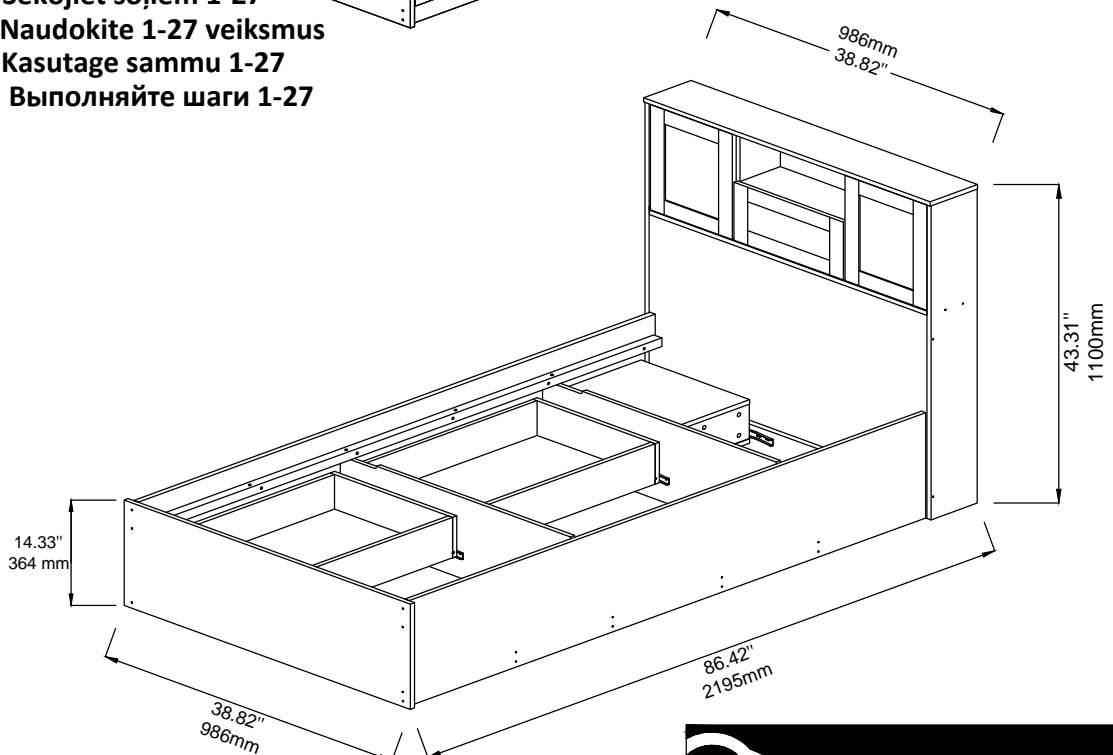

EN : Use Step 28-35  
LV : Sekojiet soļiem 28-35  
LT : Naudokite 28-35 veiksmus  
EE : Kasutage sammu 28-35  
RU : Выполняйте шаги 28-35



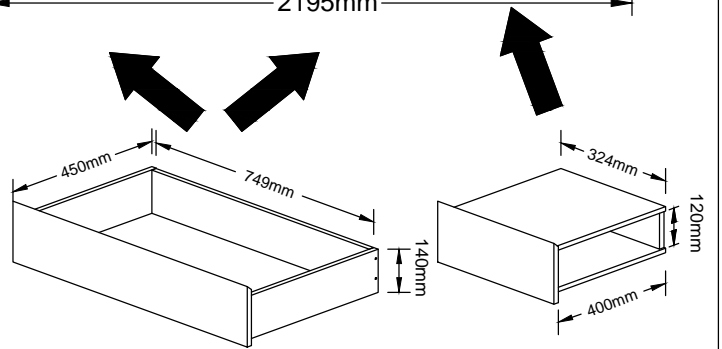
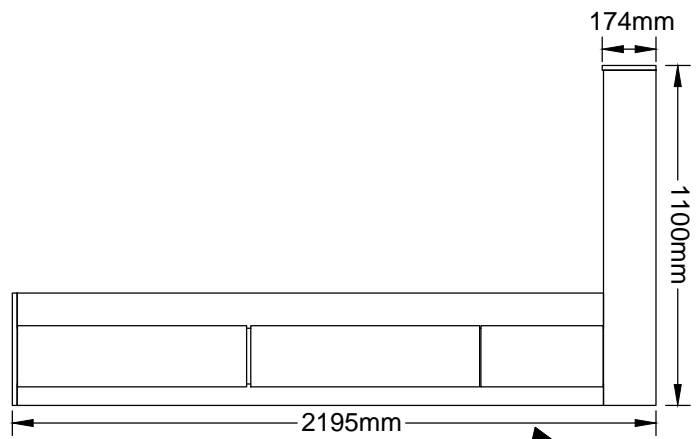
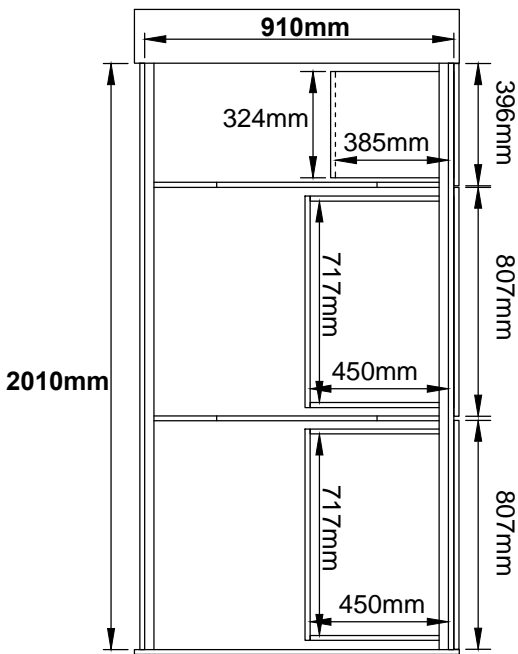
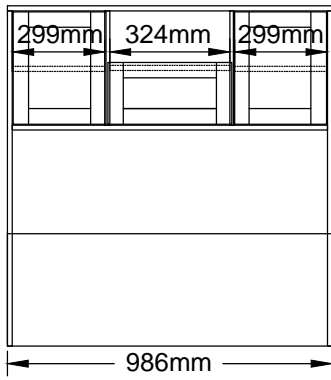

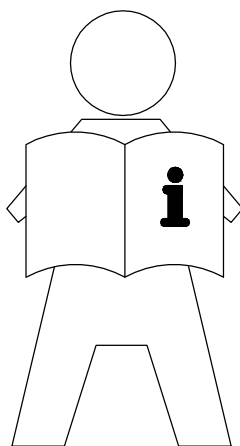

**EN: IMPORTANT INFORMATION!**

*Please read the entire manual carefully before starting to assemble and/or using this product. Follow the manual thoroughly and keep it for further reference.*

**FR: INFORMATIONS IMPORTANTES**

*Veillez lire attentivement l'ensemble du manuel avant de commencer à monter et/ou utiliser ce produit. Suivez rigoureusement le manuel et conservez-le pour toute consultation ultérieure.*

**LV: SVARĪGA INFORMĀCIJA!**

*Pirms šī izstrādājuma montāžas un/vai lietošanas uzsākšanas pilnībā izlasiet lietošanas pamācību. Stingri ievērojiet pamācības norādījumus un saglabājiet to turpmākai lietošanai.*

**LT: SVARBI INFORMACIJA!**

*Prieš pradėdami montuoti gaminį, ir (arba) juo naudotis, prašome atidžiai perskaityti visą vadovą. Atidžiai skaitykite vadovą ir turėkite jį su savimi, kad galėtumėte toliau vadovautis jo nuorodomis.*

**EE: OLULINE TEAVE!**

*Enne kui alustate toote kokku panemist ja/või kasutamist, lugege see kasutusjuhend hoolikalt läbi. Järgige täpselt juhendis toodud juhiseid ja hoidke juhend alles.*

**RU: ВАЖНАЯ ИНФОРМАЦИЯ!**

*Внимательно и полностью прочитайте это руководство, прежде чем приступить к сборке или использованию этого изделия. Следуйте всем инструкциям этого руководства и сохраните его на будущее для справки.*

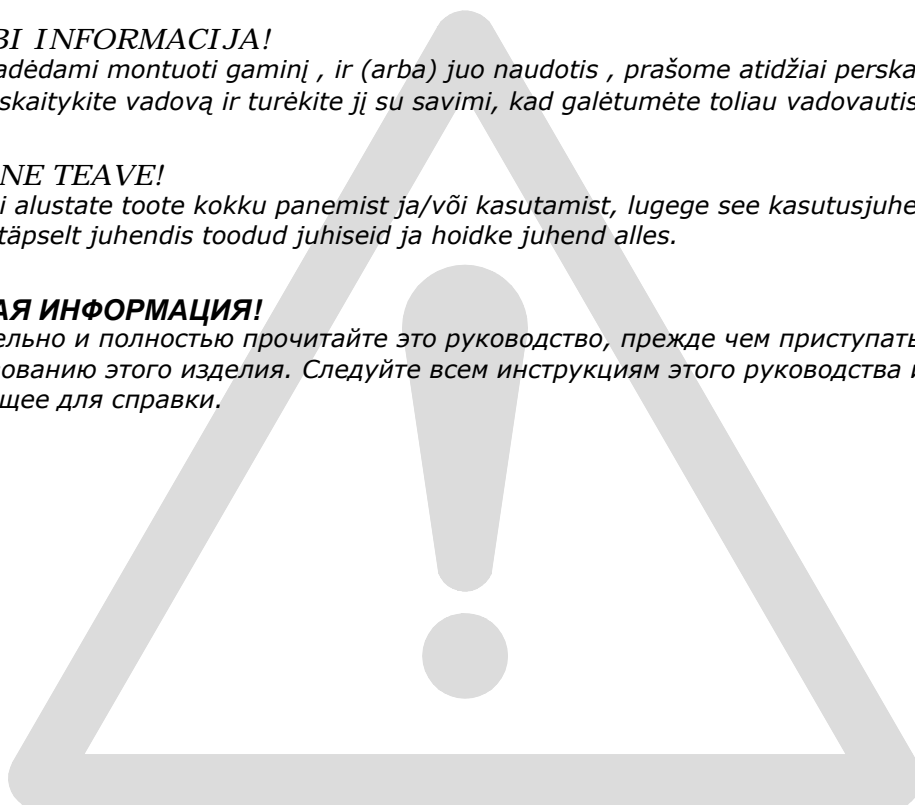

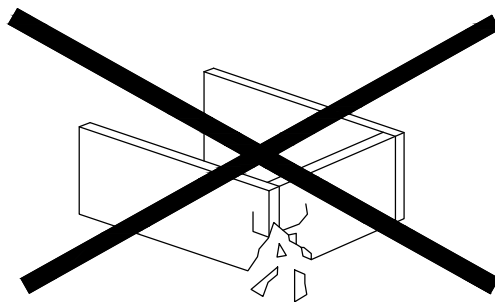
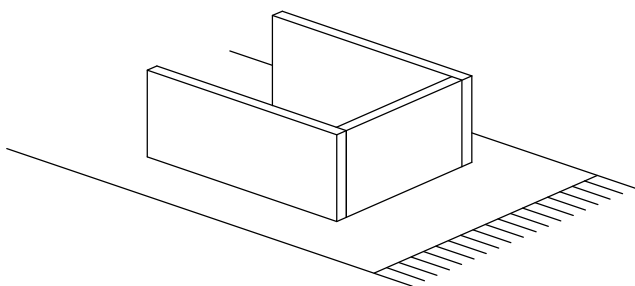

**EN:** **WARNING TO AVOID SCRATCHES!**  
*In order to avoid scratching this furniture should be assembled on a soft layer - could be a rug.*

**FR:** **AVERTISSEMENT POUR ÉVITER LES RAYURES**  
*Afin d'éviter les rayures, ce meuble doit être monté sur une surface souple (un tapis, par exemple).*

**LV:** **BRĪDINĀJUMS PAR SKRĀPĒJUMIEM!**  
*Lai nesaskrāpētu šo izstrādājumu, veiciet montāžu uz mīkstas pamatnes, piemēram, paklāja.*

**LT:** **ĮSPĖJIMAS, KAD IŠVENGTUMĖTE ĮBRĖŽIMŲ!**  
*Šio baldo nesubraižysite, jei jį surinksite ant švelnaus paviršiaus, pavyzdžiui, kilimo.*

**EE:** **HOIATUS KRIIMUSTUSTE VÄLTIMISEKS!**  
*Kriimustuste tekkimise vältimiseks mööblile tuleb see kokku panna pehmel pinnal, nt kaltsuvaibal.*

**RU:** **ПРЕДУПРЕЖДЕНИЕ ОТНОСИТЕЛЬНО ЦАРАПИН!**  
*Во избежание нанесения царапин, сборку этой мебели необходимо выполнять на мягкой поверхности, например на ковре.*



- EN:** **IMPORTANT!**  
*It is important that any product which is assembled using any kind of screw is re-tightened 2 weeks after assembly, and once every 3 months - in order to assure stability through-out the lifespan of the product.*
- FR:** **IMPORTANT**  
*Il est important que tout produit monté à l'aide de vis soit resserré 2 semaines après son montage, puis tous les 3 mois, afin de garantir sa stabilité durant tout son cycle de vie.*
- LV:** **SVARĪGI!**  
*Ir svarīgi, lai jebkuram produktam, kas tiek uzstādīts ar jebkādu skrūvju palīdzību, skrūves tiktu atkārtoti pievilktas 2 nedēļas pēc montāžas, pēc tam - reizi 3 mēnešos, tā nodrošinot stabilitāti visā izstrādājuma kalpošanas laikā.*
- LT:** **SVARBU!**  
*Bet kokį varžtais tvirtinamą gaminį 2 savaites po surinkimo bei kas 3 mėnesius reikia papildomai suveržti - taip užtikrinamas naudojamo gaminių stabilumas.*
- EE:** **TÄHTIS!**  
*Oluline on, et toote kruvisid pingutataks 2 nädalat pärast kokkupanekut ja seejärel iga 3 kuu järel, et tagada stabiilsus kogu toote eluea jooksul.*
- RU:** **ВАЖНО!**  
*В любом изделии, собранном с использованием винтов любого типа, необходимо через 2 недели после сборки и в дальнейшем каждые 3 месяца подтягивать винты, чтобы обеспечить прочность изделия в течение срока эксплуатации.*





- EN:** *GENERAL INSTRUCTION FOR FURNITURE MADE OF WOOD OR WOOD COMPOSITES SUCH AS MELAMINE, LAMINATE OR VENEER SURFACES!  
Wipe clean with a damp cloth. Use only water or a gentle detergent.  
Wipe dry with a clean cloth.*
- FR:** ***INSTRUCTIONS GÉNÉRALES POUR LE MOBILIER CONSTITUÉ DE BOIS OU DE COMPOSITES DE BOIS (COMME LES SURFACES EN MELAMINÉ, STRATIFIÉ OU PLACAGE )**  
Nettoyer à l'aide d'un chiffon humide. Utiliser uniquement de l'eau ou un détergent doux.  
Essuyer à l'aide d'un chiffon propre.*
- LV:** ***VISPĀRĒJI NORĀDĪJUMI MĒBELĒM NO KOKA VAI KOKSNES KOMPOZĪTIEM, PIEMĒRAM, MELAMĪNA, LAMINĀTA VAI FINIERA VIRSMĀM!**  
Noslaukiet ar mitru drānu. Lietojiet tikai ūdeni vai maigu mazgāšanas līdzekli.  
Nosusiniet ar tīru drānu.*
- LT:** ***BALDŲ IŠ MEDIENOS AR MEDIENOS KOMPOZITO, DENGTO MELAMINU, LAMINATU AR PLONU FANEROS SLUOKSNIU, BENDRIEJI VALYMO NURODYMAI!**  
Valykite drėgnu skudurėlu. Naudokite tik vandenį arba švelnų valikį.  
Nusausinkite švari skudurėliu.*
- EE:** ***PUIDUST VÕI MITMEKIHILISEST PUIDUST, NAGU MELAMIINIST, LAMINAADIST VÕI VINEERIST MÖÖBLI ÜLDJUHISED!**  
Kasutage puhastamiseks niisket lappi. Kasutage ainult vett või õrnatoimelist puhastusvahendit.  
Pühkige puhta lapiga kuivaks.*
- RU:** ***ОБЩИЕ УКАЗАНИЯ ОТНОСИТЕЛЬНО МЕБЕЛИ, ИЗГОТОВЛЕННОЙ ИЗ ДЕРЕВА ИЛИ ДРЕВЕСНЫХ КОМПОЗИЦИОННЫХ МАТЕРИАЛОВ, ТАКИХ КАК МЕЛАМИН, ЛАМИНАТ ИЛИ ШПОН!**  
Очистите изделие чистой влажной тканью. Используйте мягкодействующее моющее средство.  
Вытрите досуха чистой тряпкой.*

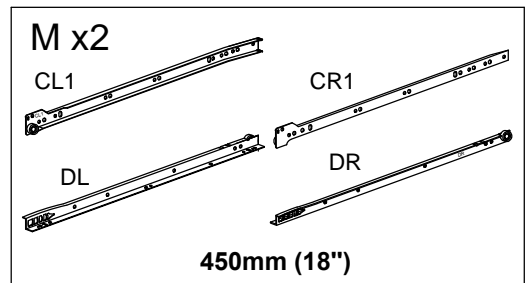
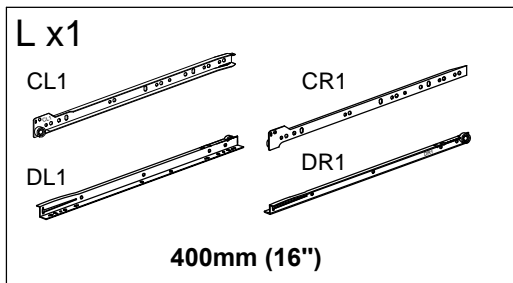
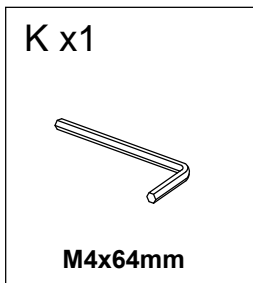
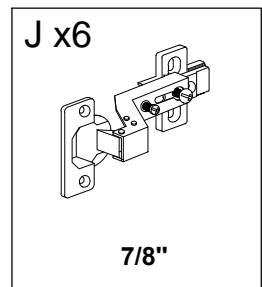
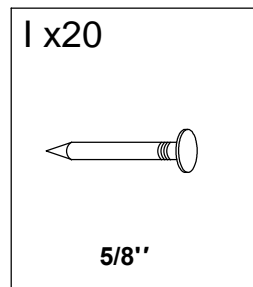
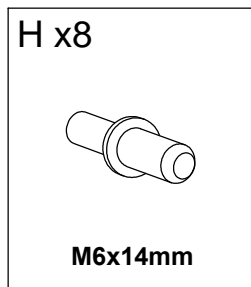
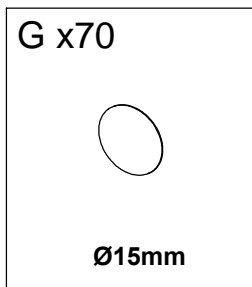
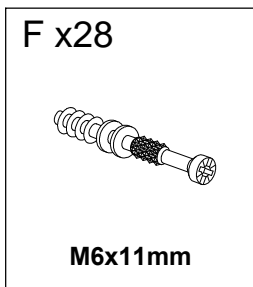
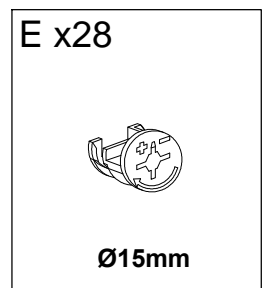
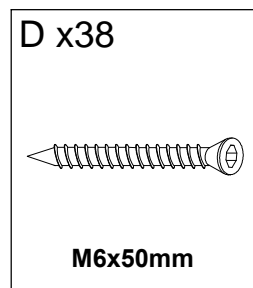
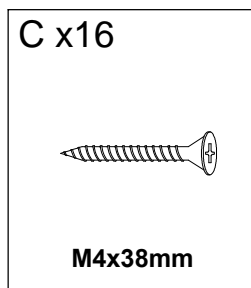
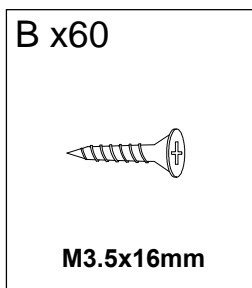
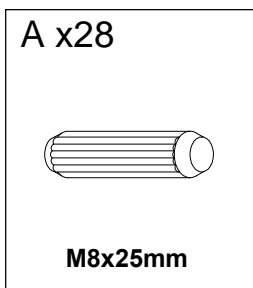
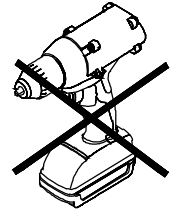
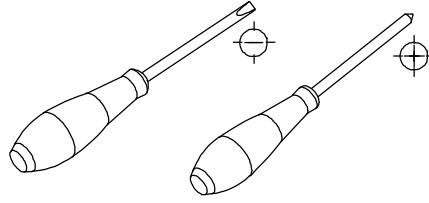
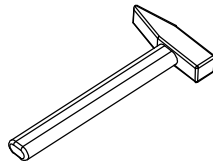
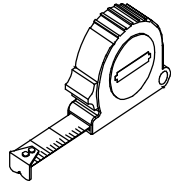
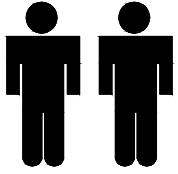

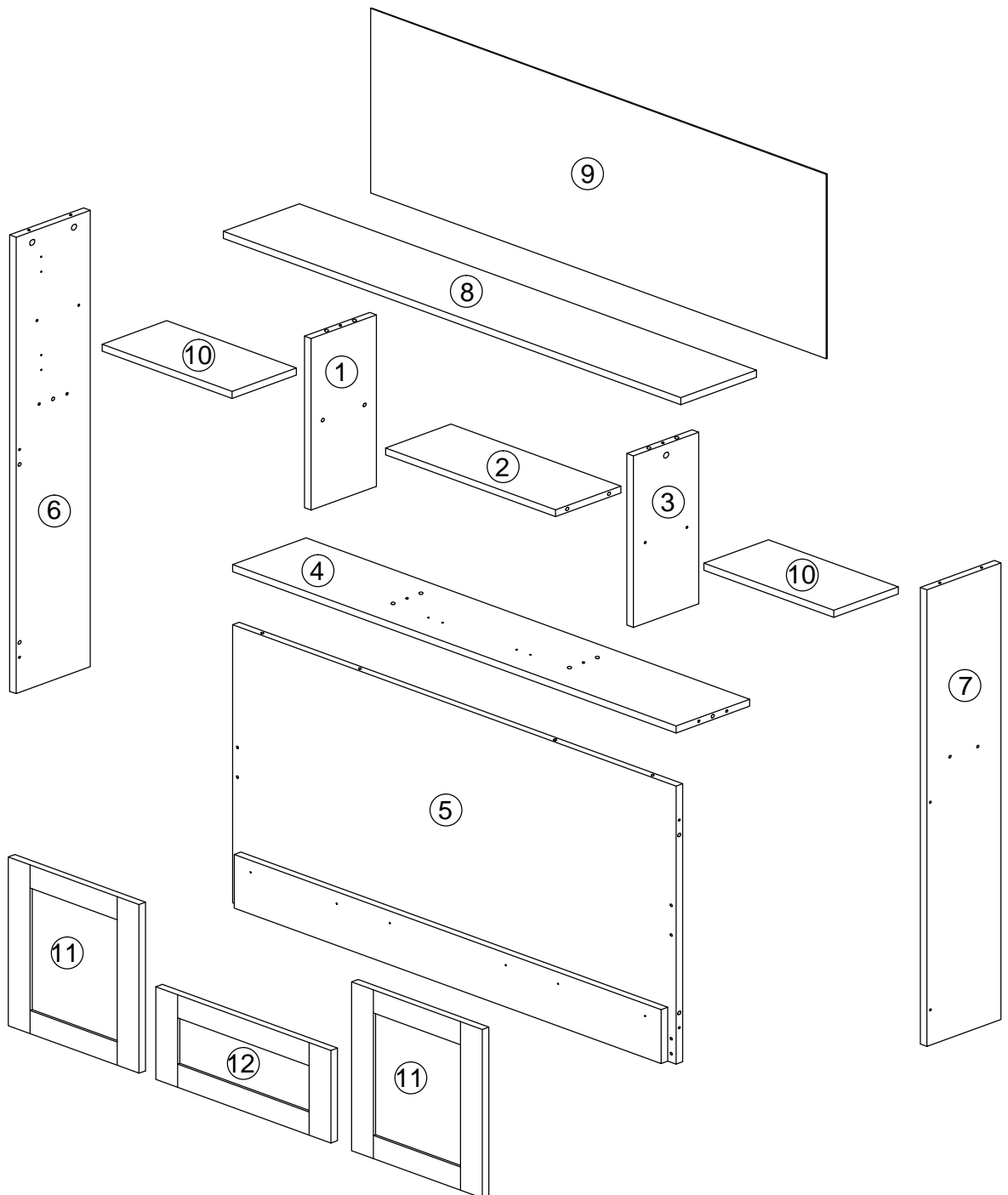
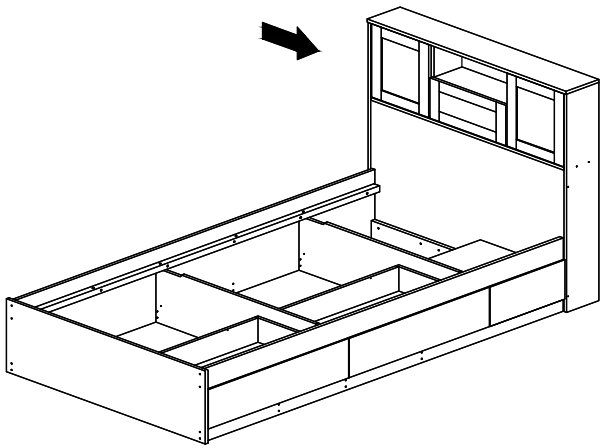

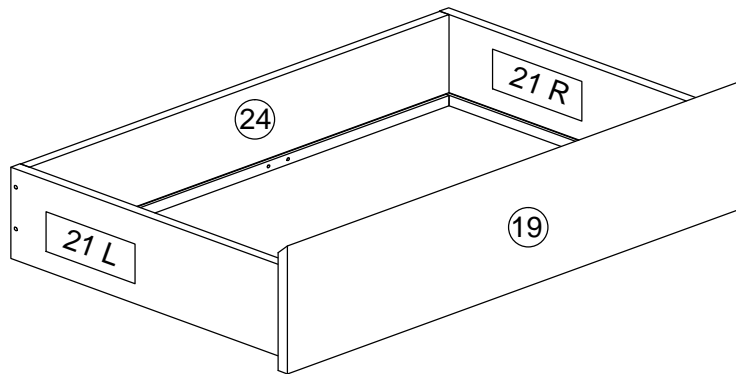
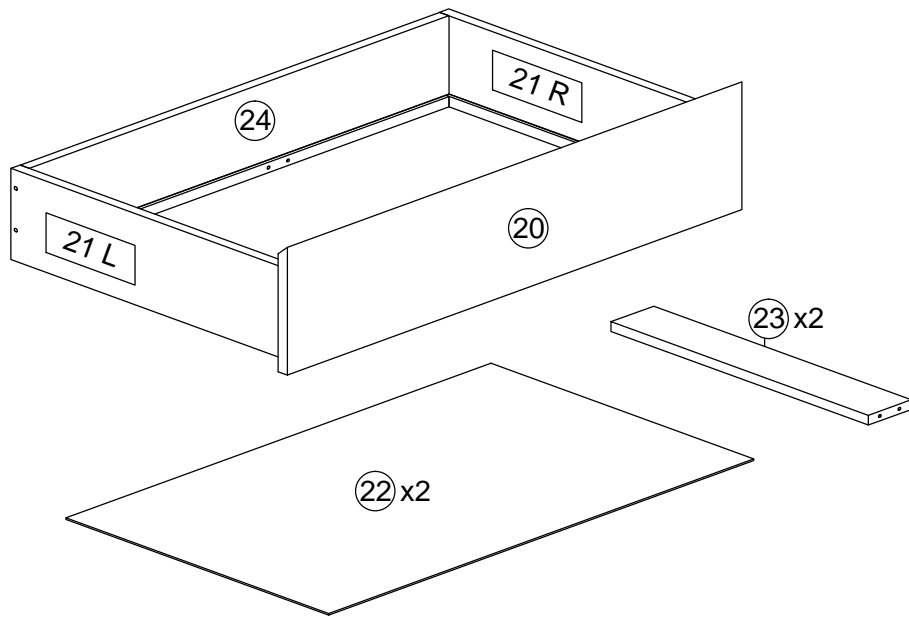
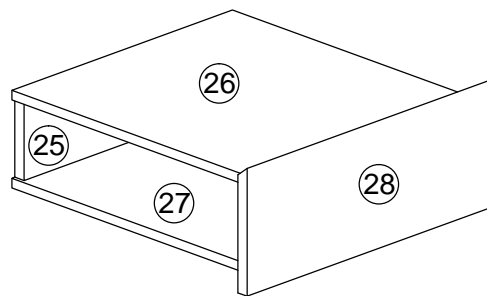
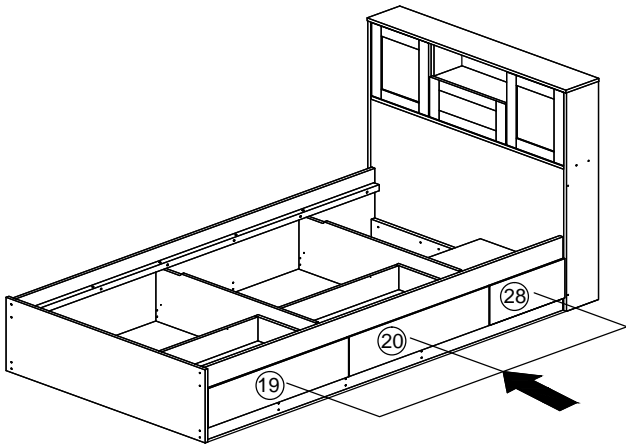

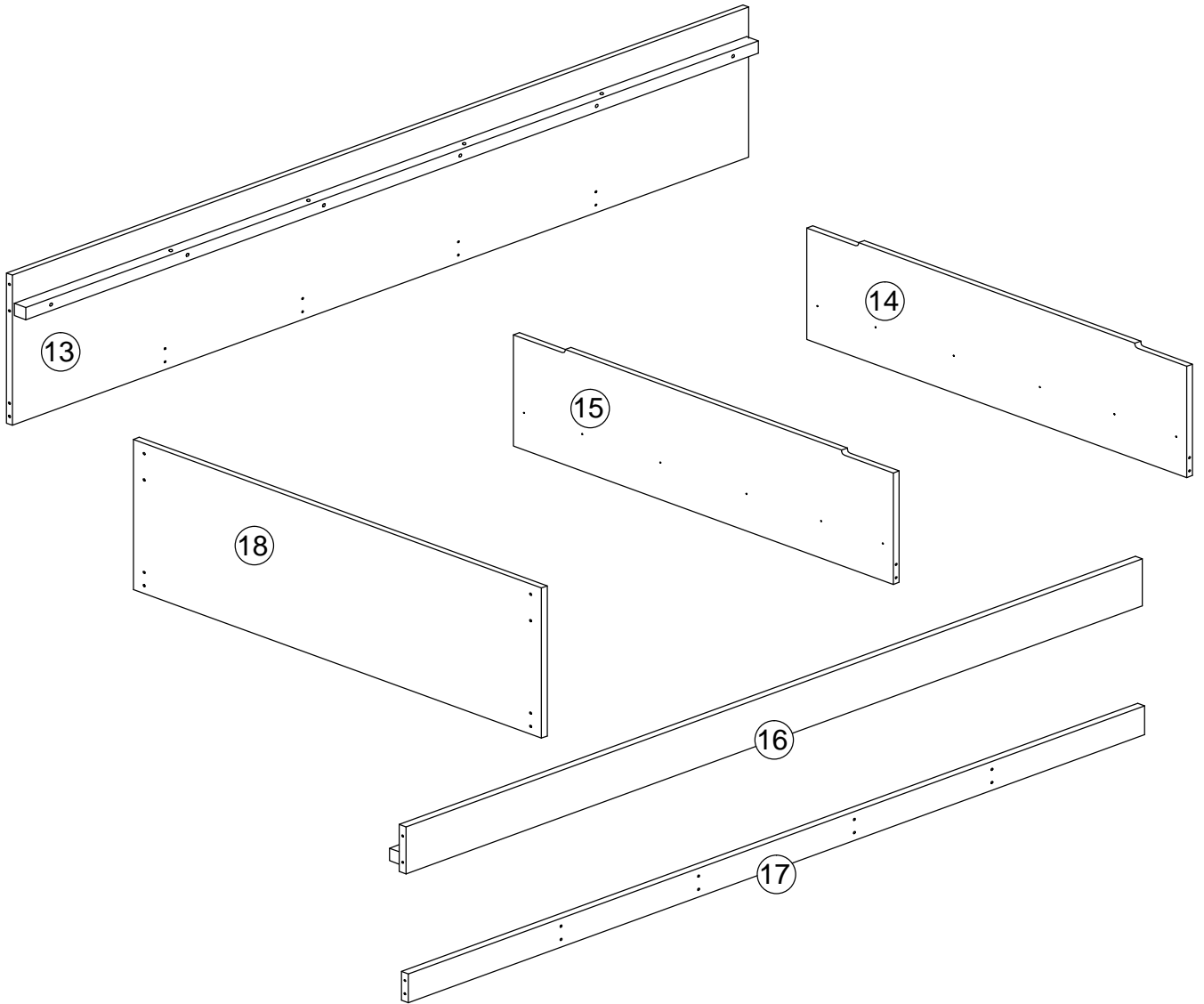
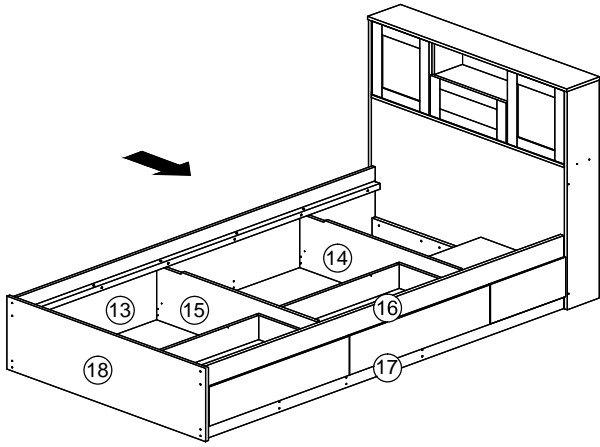

**BOX 1/3**

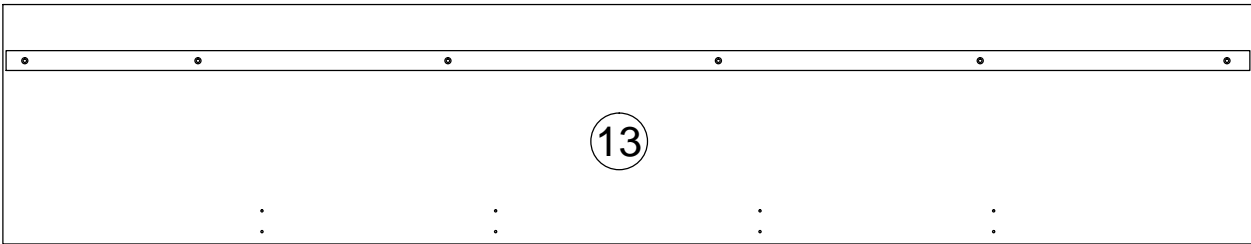

2010 x 364 x 15 mm

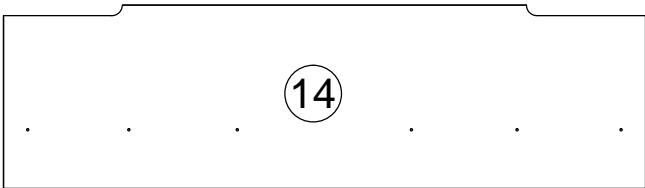

907 x 280 x 15 mm

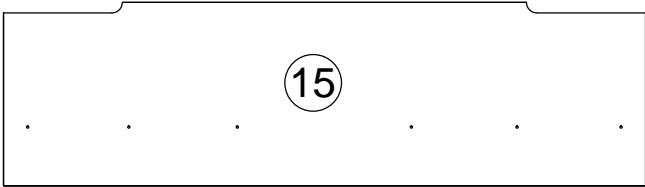

907 x 280 x 15 mm

16

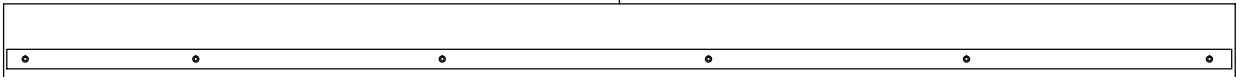

2010 x 114 x 18 mm

17

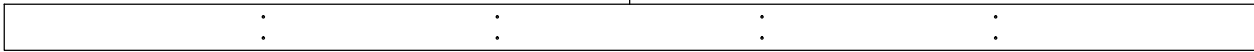

2010 x 70 x 18 mm

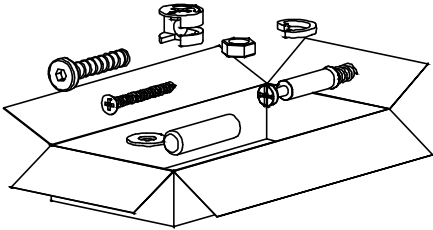

# BOX 2/3

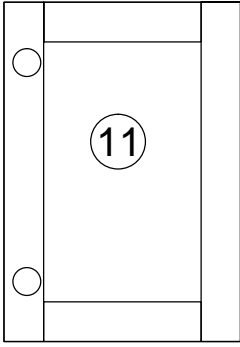

364 x 301 x 15 mm

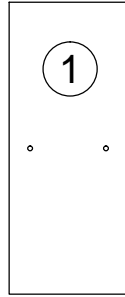

370 x 150 x 15 mm

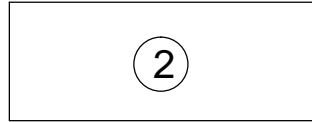

324 x 150 x 15 mm

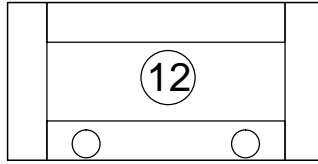

200 x 336 x 15 mm

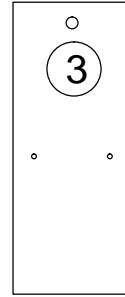

370 x 150 x 15 mm

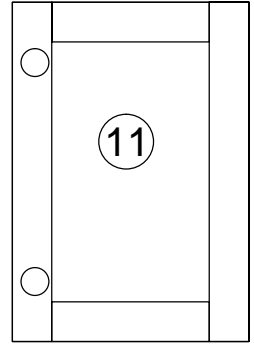

364 x 301 x 15 mm

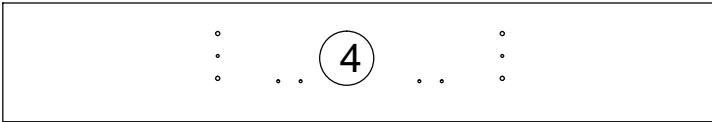

954 x 169 x 15 mm

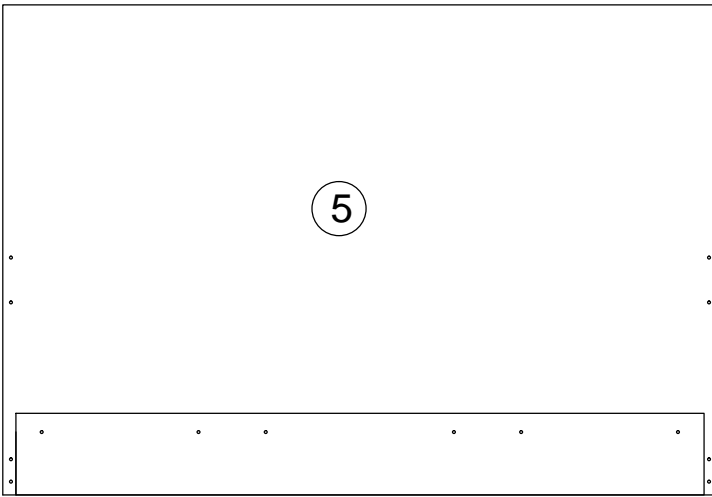

954 x 700 x 15 mm

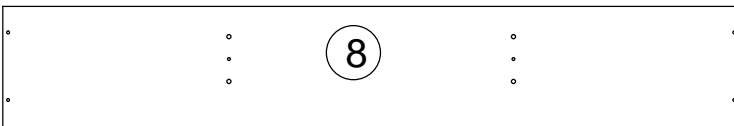

986 x 174 x 15 mm

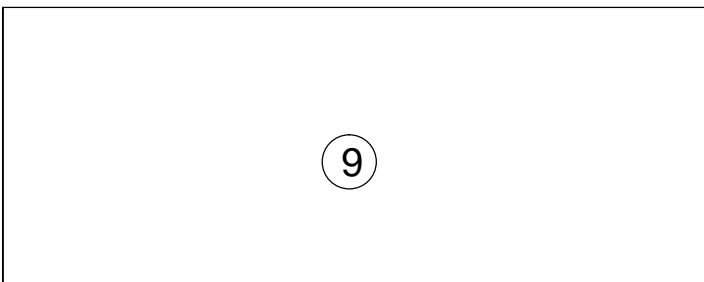

982 x 398 x 2.5 mm

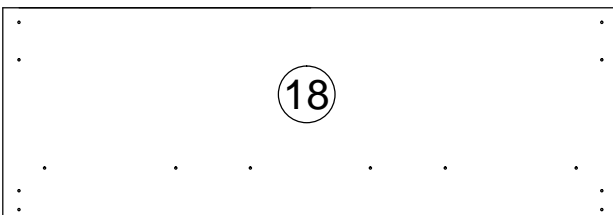

986 x 364 x 15 mm

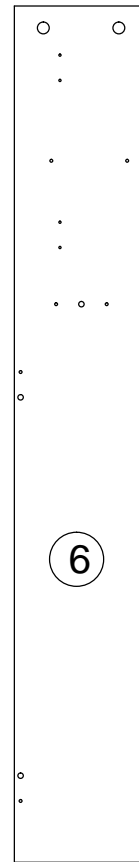

1086 x 170 x 15 mm

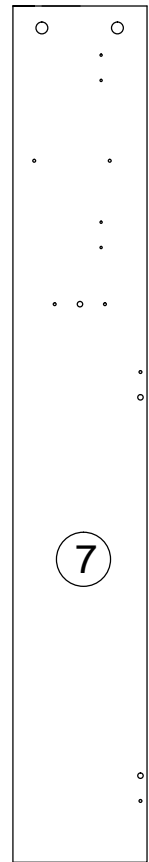

1086 x 170 x 15 mm

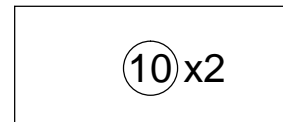

299 x 148 x 15 mm

# BOX 3/3

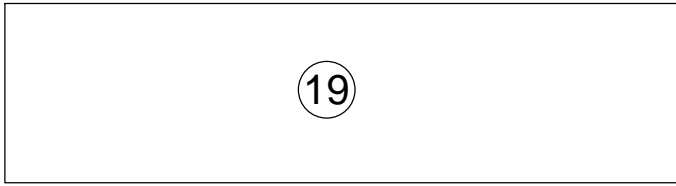

807 x 198 x 15 mm

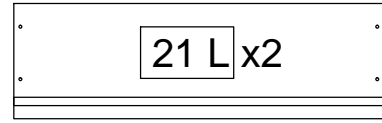

450 x 140 x 15 mm

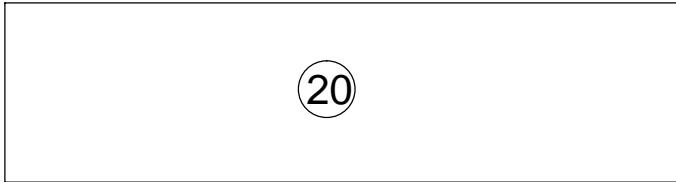

807 x 198 x 15 mm

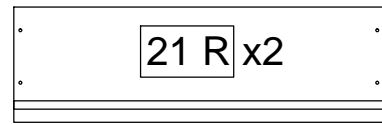

450 x 140 x 15 mm

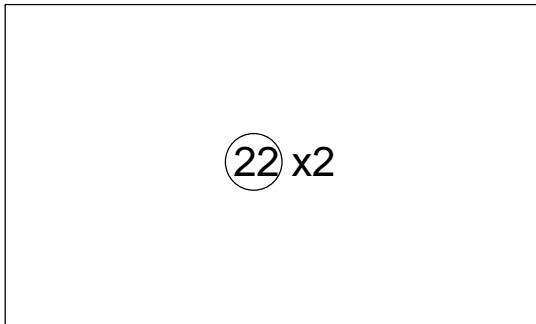

758 x 429 x 2.5 mm



420 x 70 x 15 mm

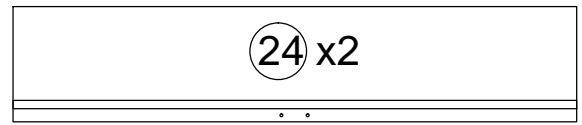

749 x 140 x 15 mm

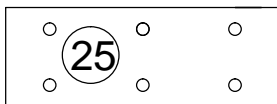

304 x 120 x 15 mm

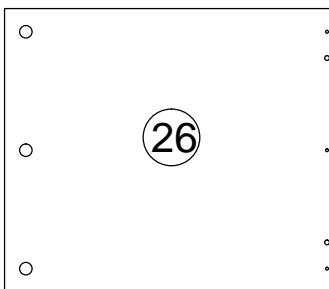

324 x 400 x 15 mm

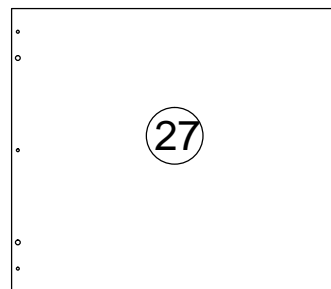

324 x 400 x 15 mm

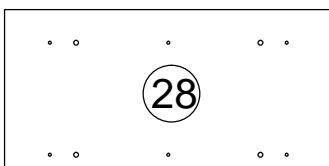

376 x 198 x 15 mm

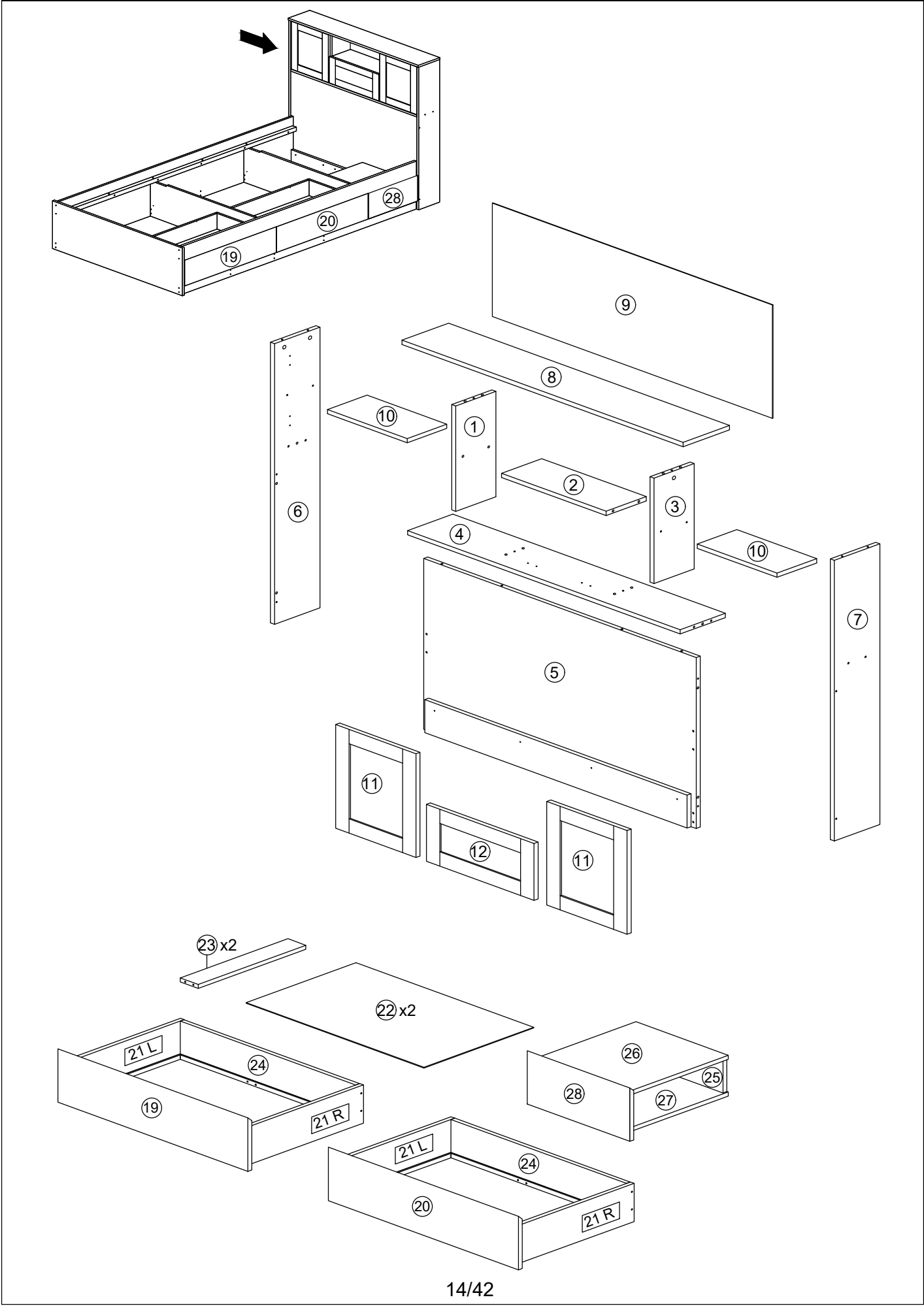

1

Ax20

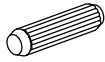

M8x25mm

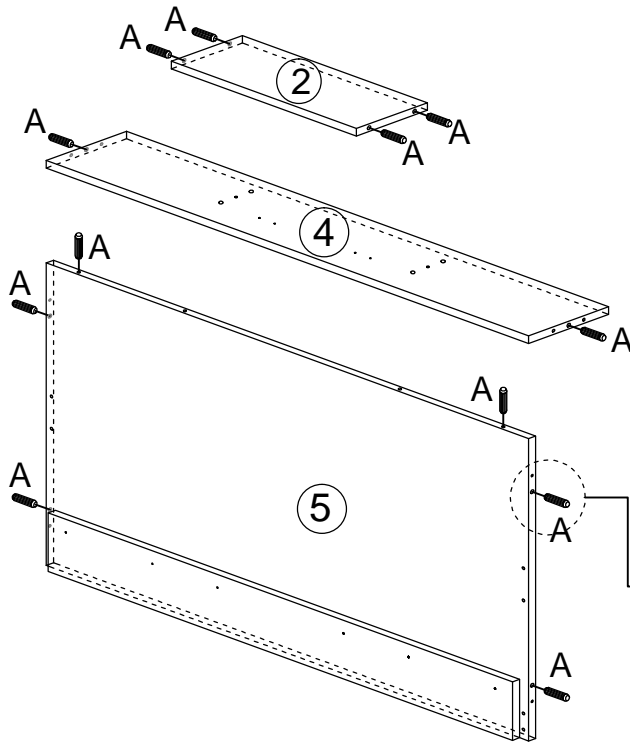
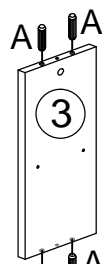
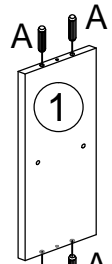
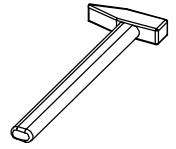

2

Fx8



M6x11mm

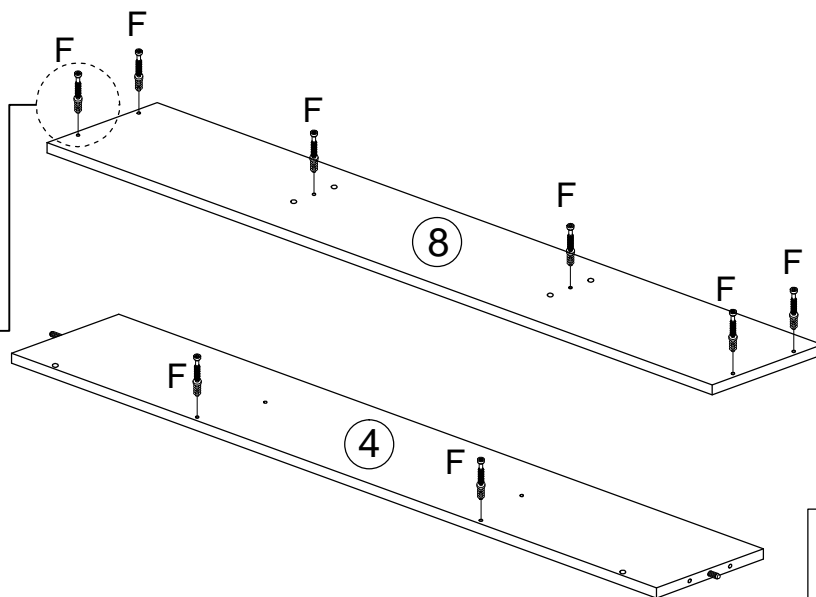
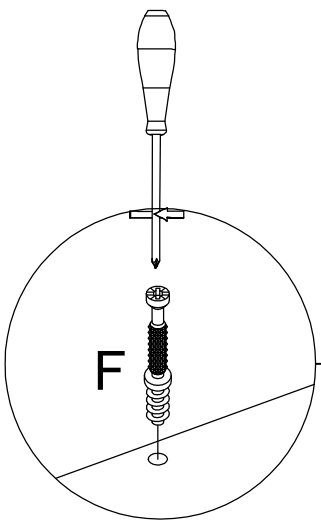
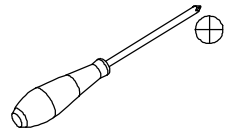

3

H x8  
M6x14mm



M6x14mm

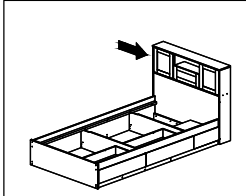
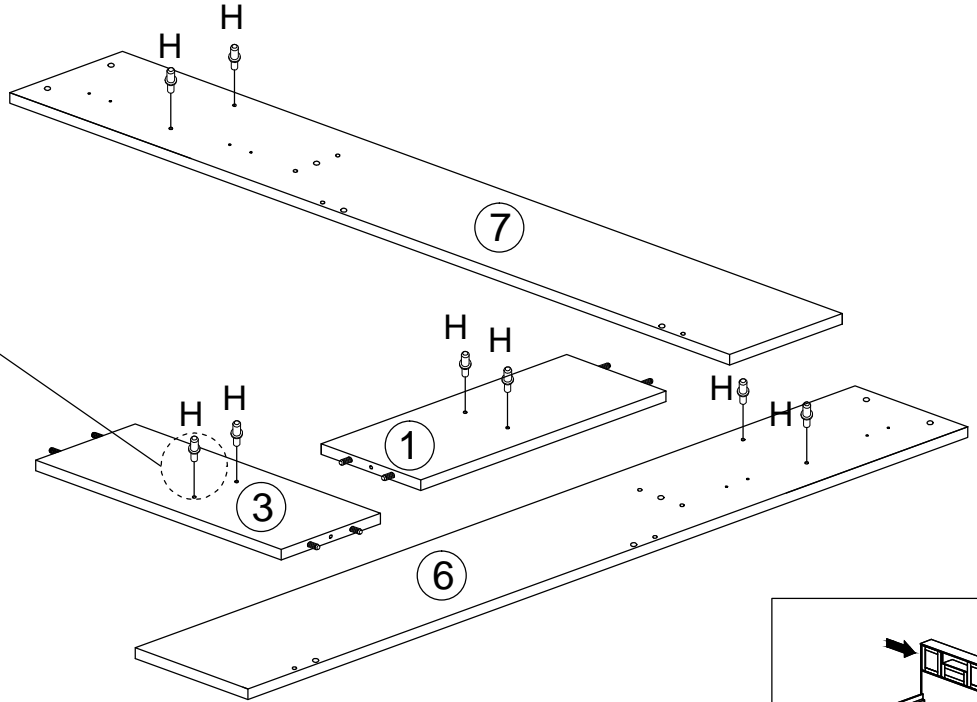
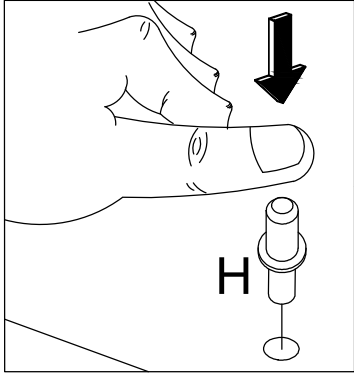

4

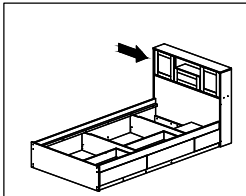
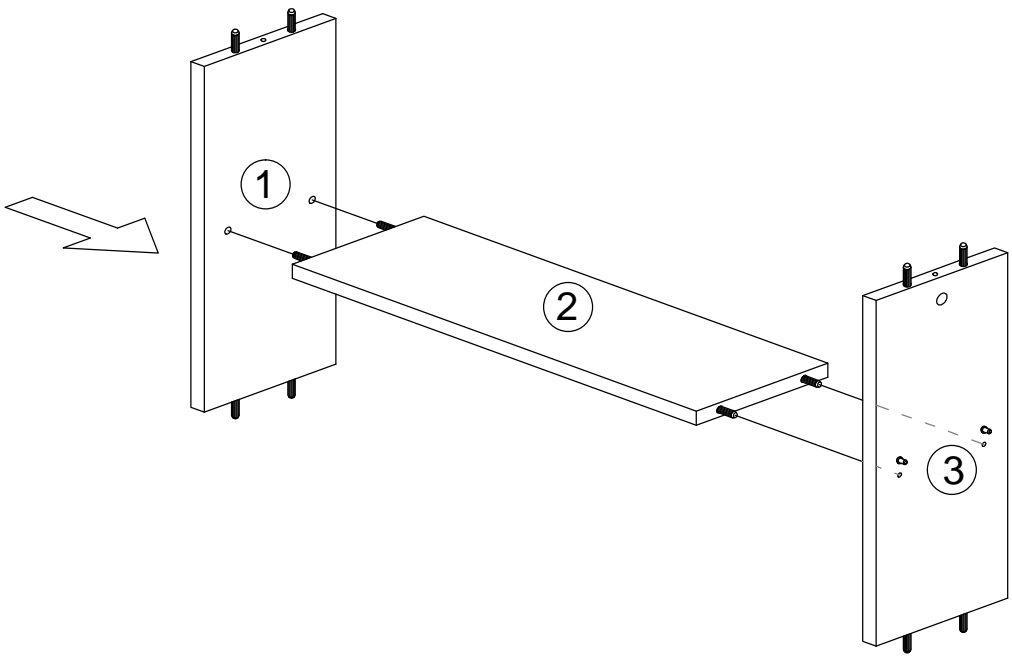
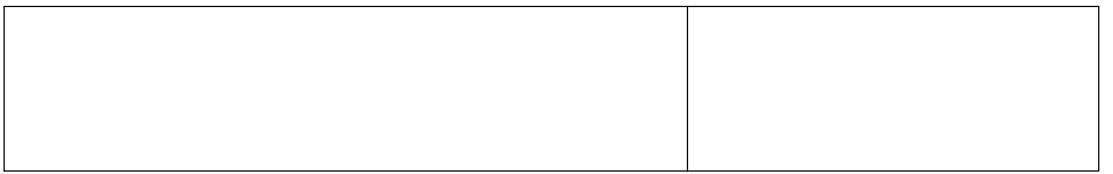

5

D x2 M6x50mm	K x1 M4x64mm	G x2 Ø15mm	
-----------------	-----------------	---------------	--

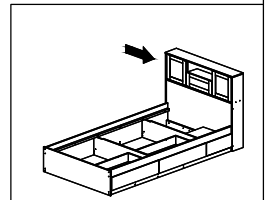
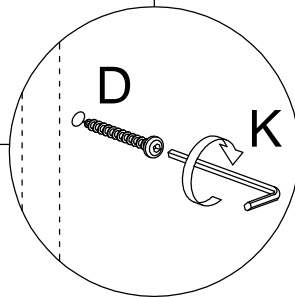
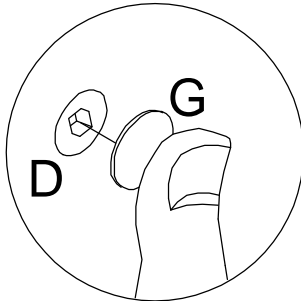
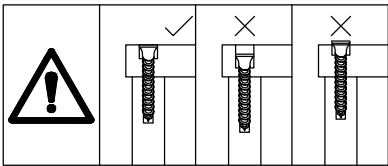
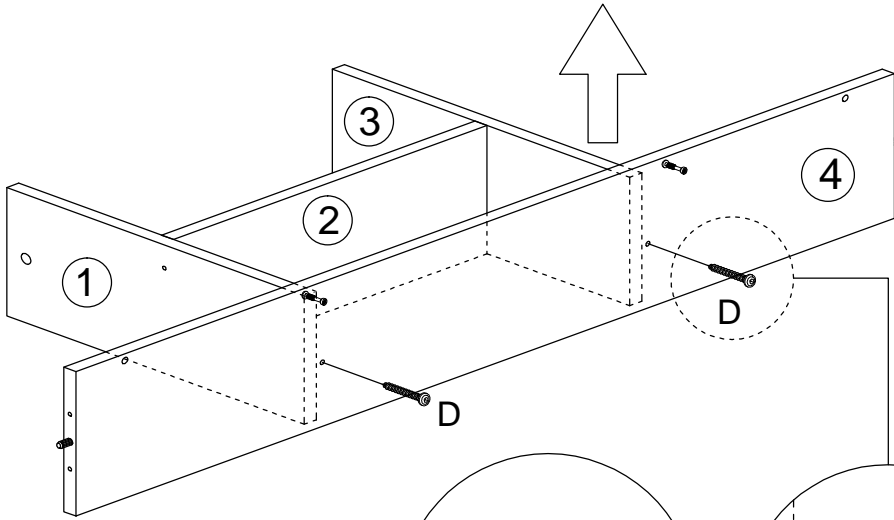

6

Dx8 M6x50mm	Ex2 Ø15mm	Gx10 Ø15mm	Kx1 M4x64mm
----------------	--------------	---------------	----------------

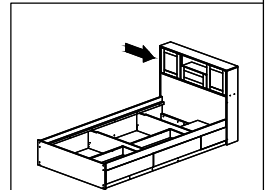
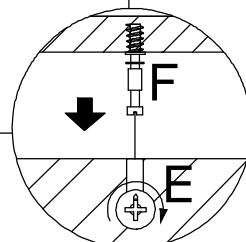
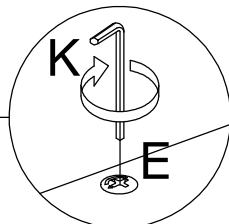
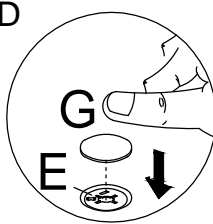
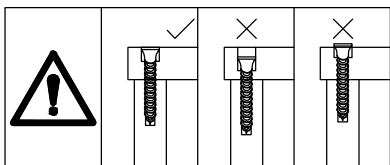
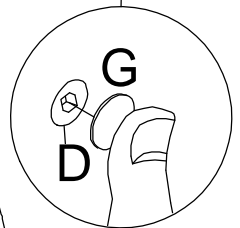
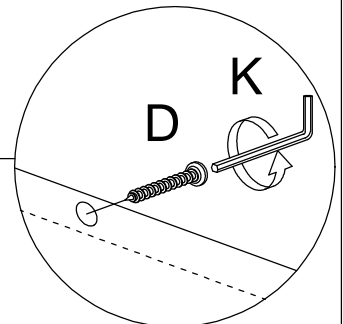
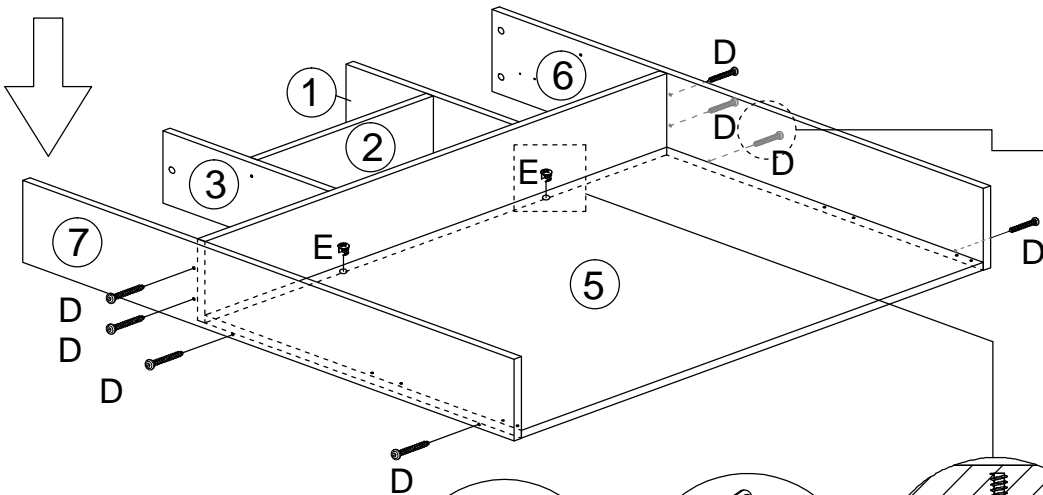

7

E x6



Ø15mm

G x6



Ø15mm

K x1

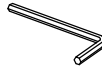

M4x64mm

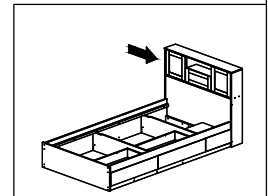
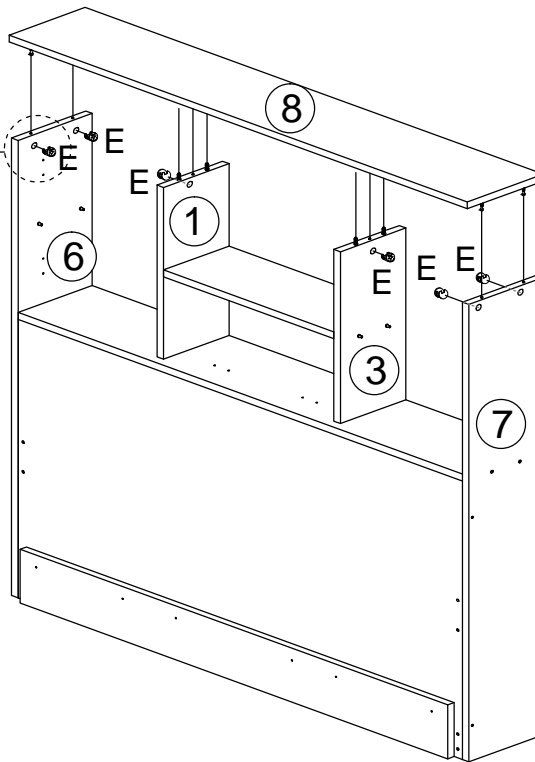
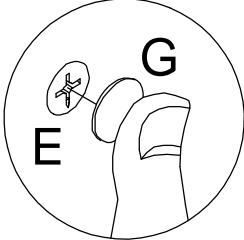
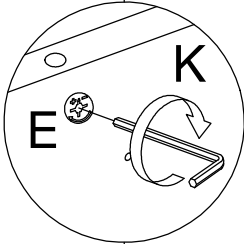
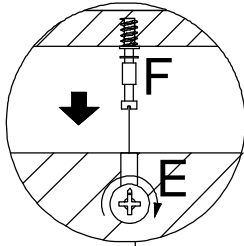

8

I x20

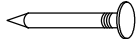

5/8"

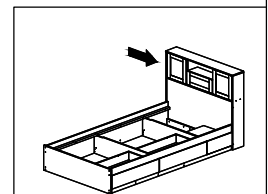
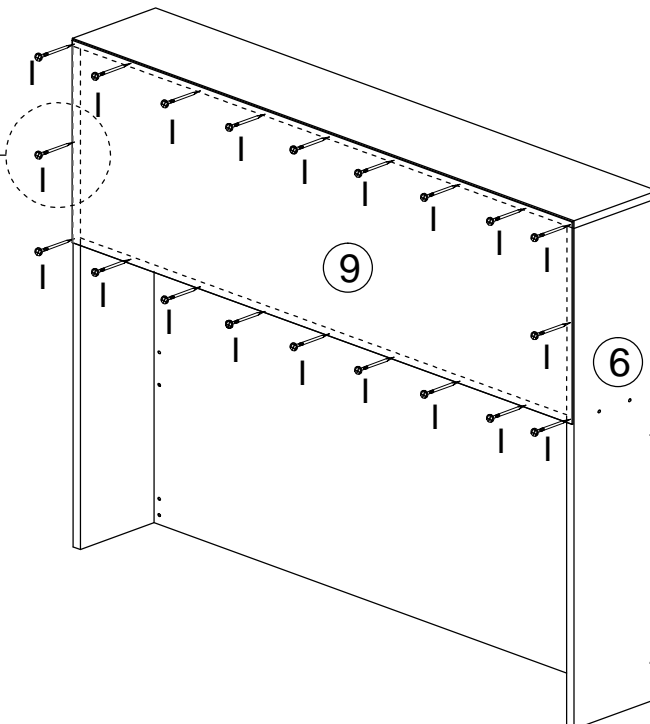
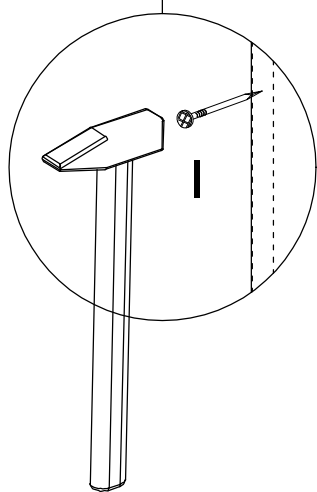
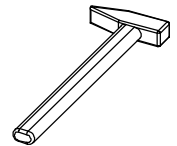

9

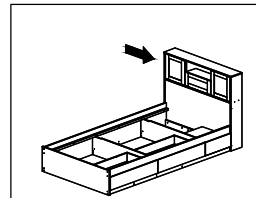
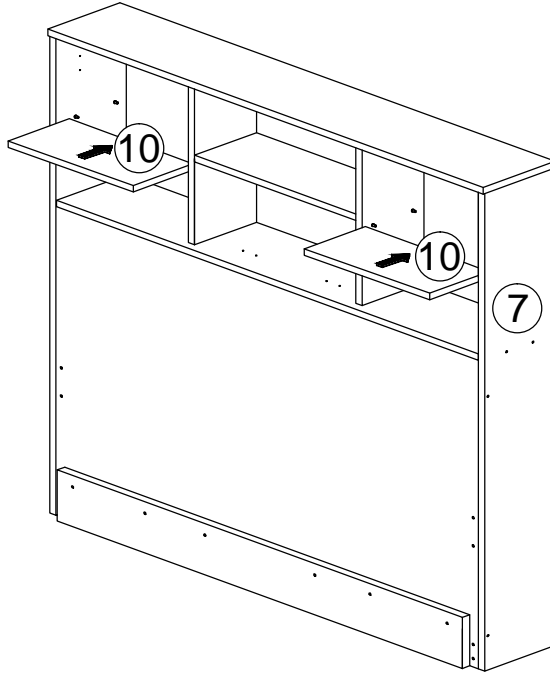

10

BX12



M3.5x16mm

Jx6



7/8"

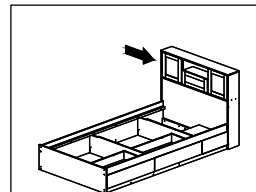
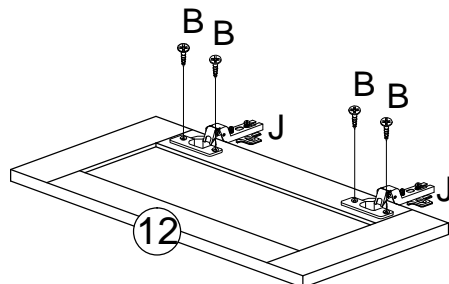
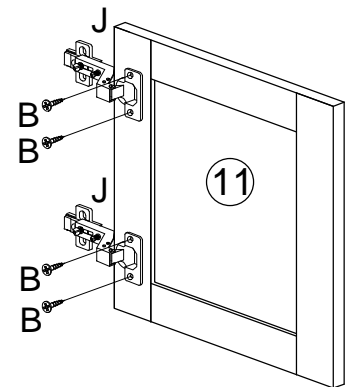
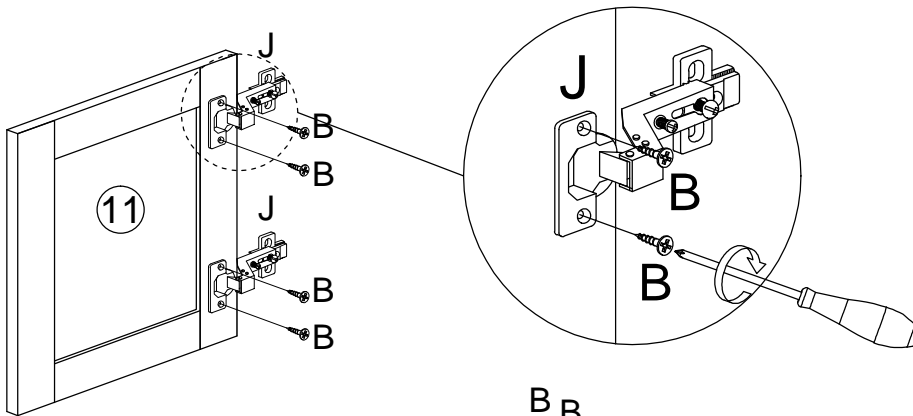
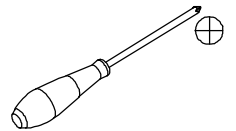

11

BX12  
M3.5x16mm

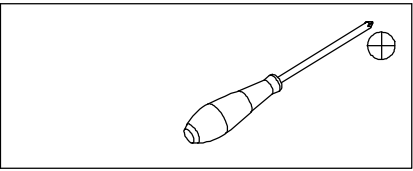

11a

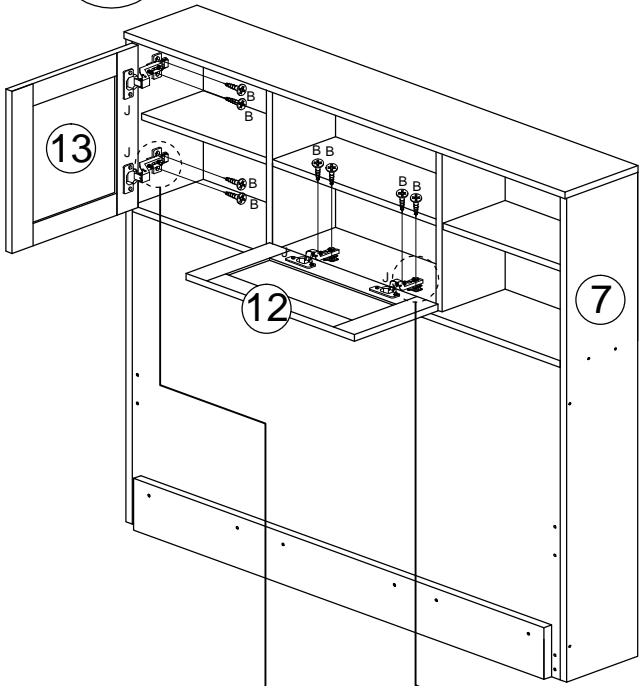

11b

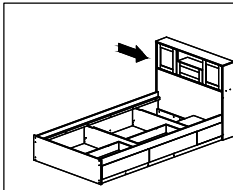
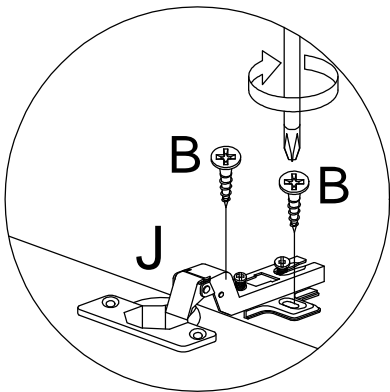
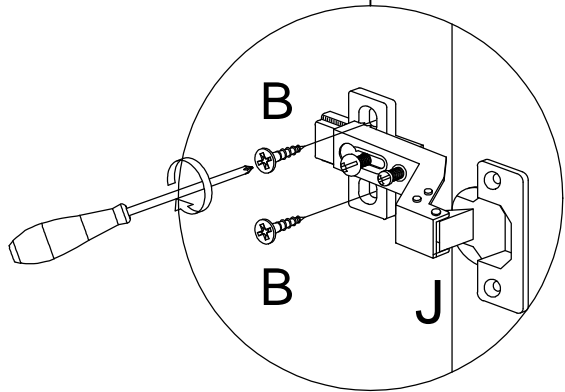
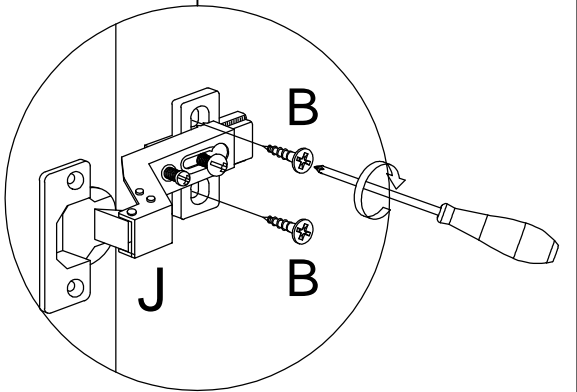
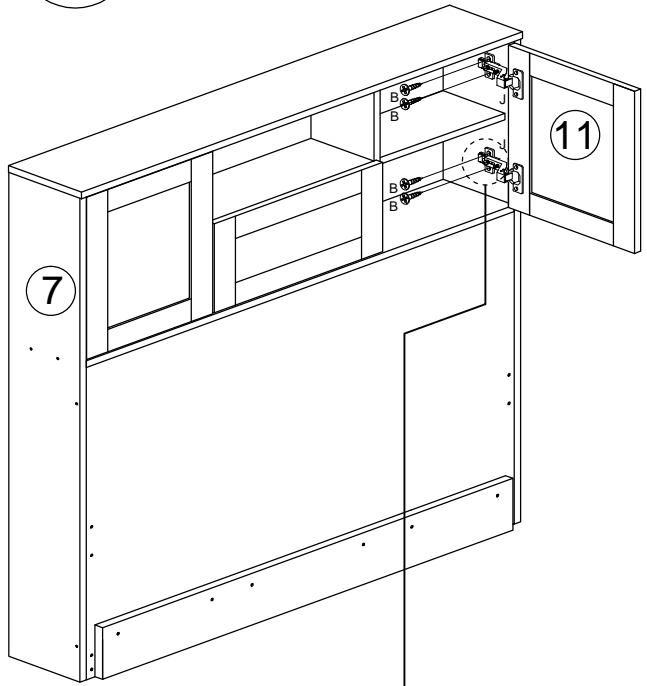

12a

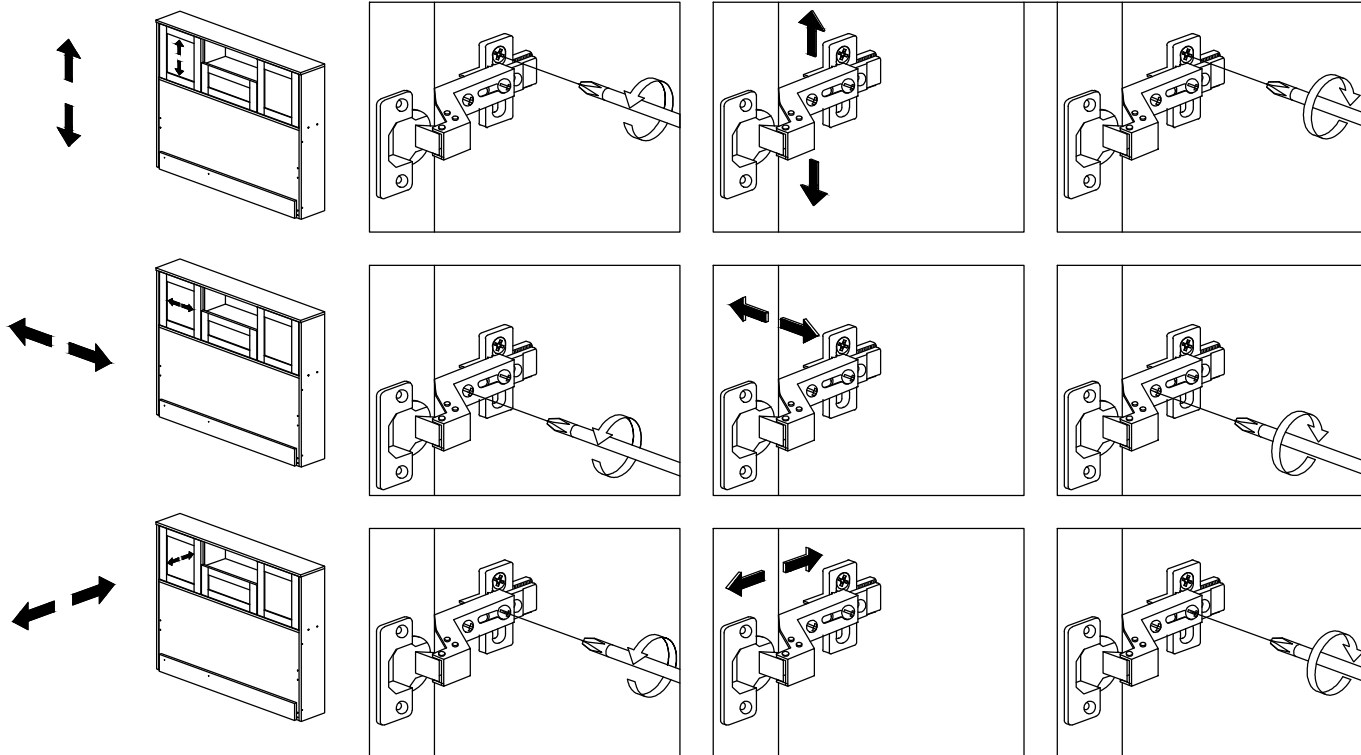
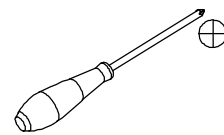

12b

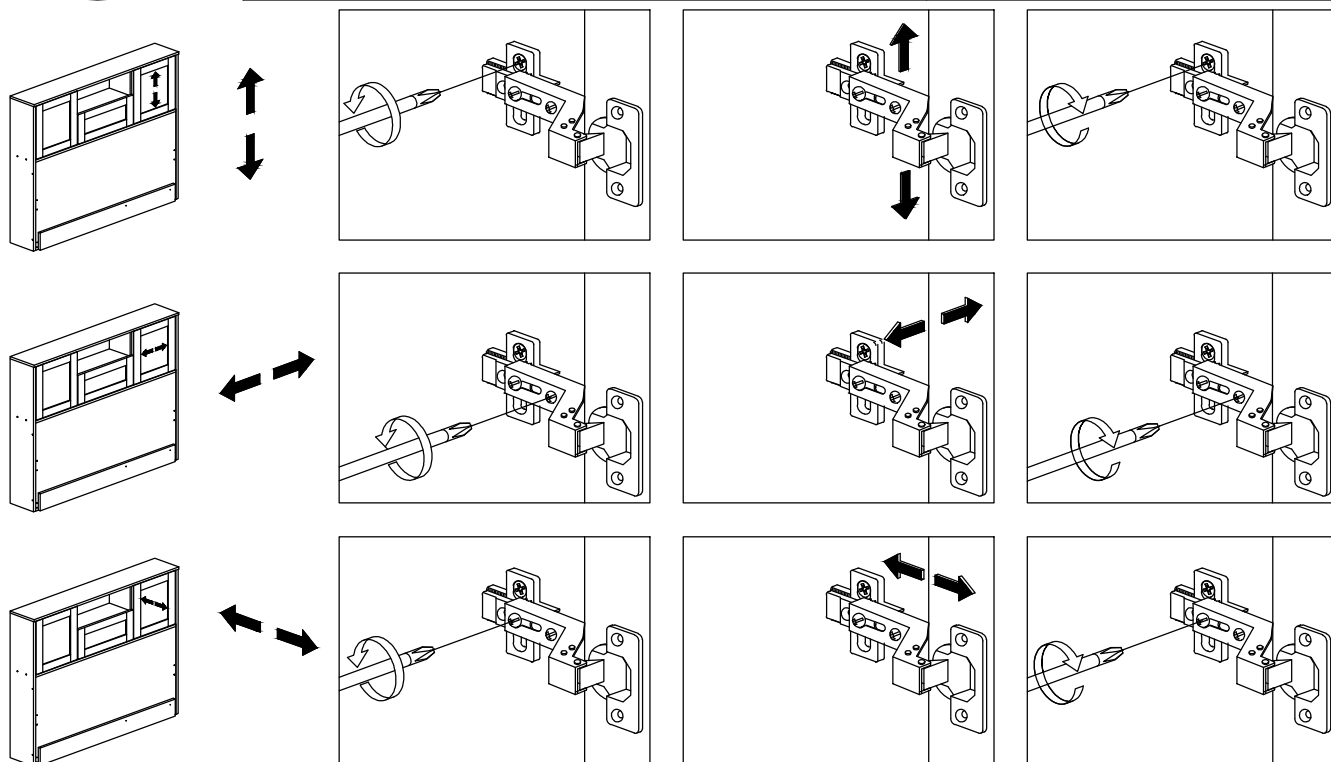
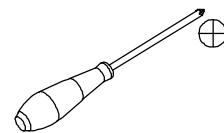

12c

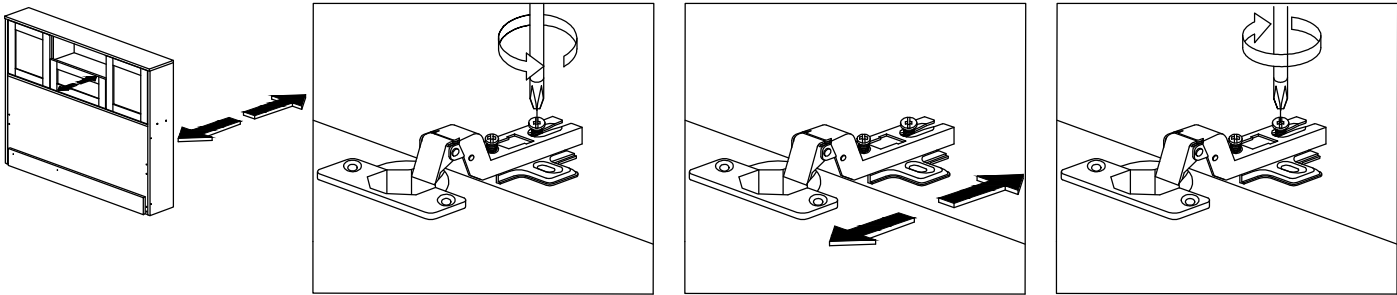
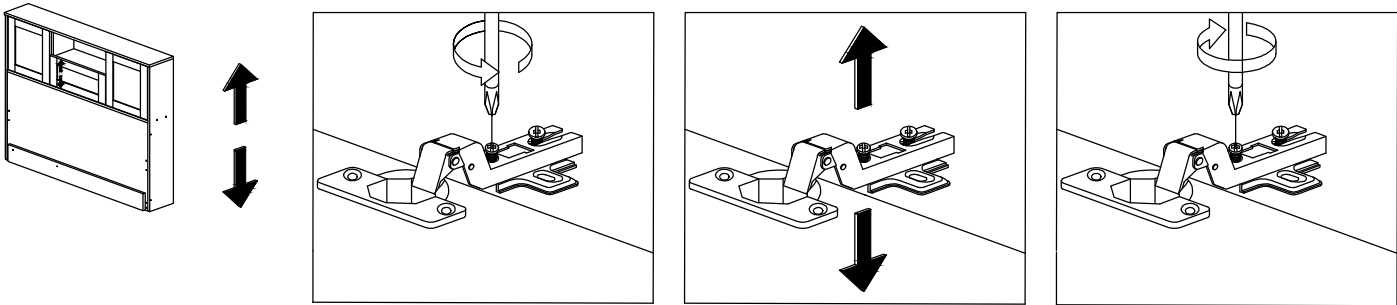
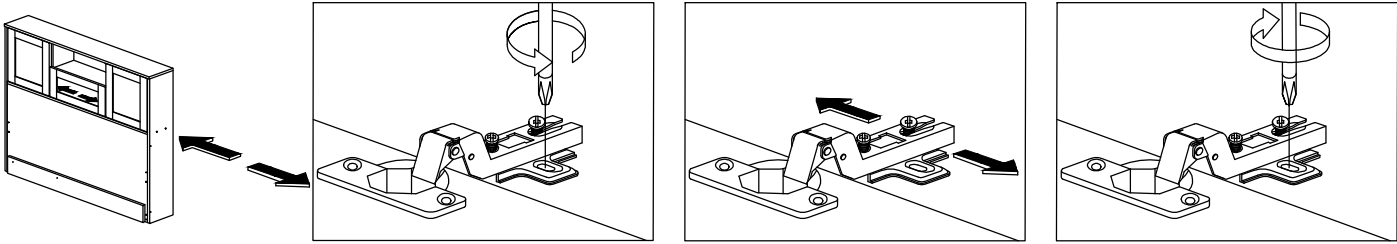
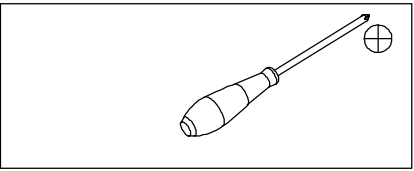
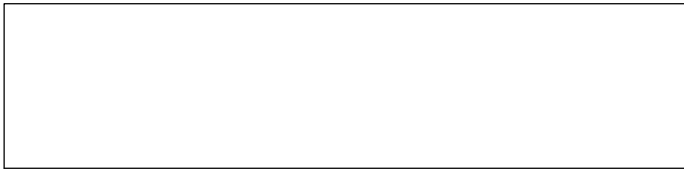

13

Ax8  
M8x25mm

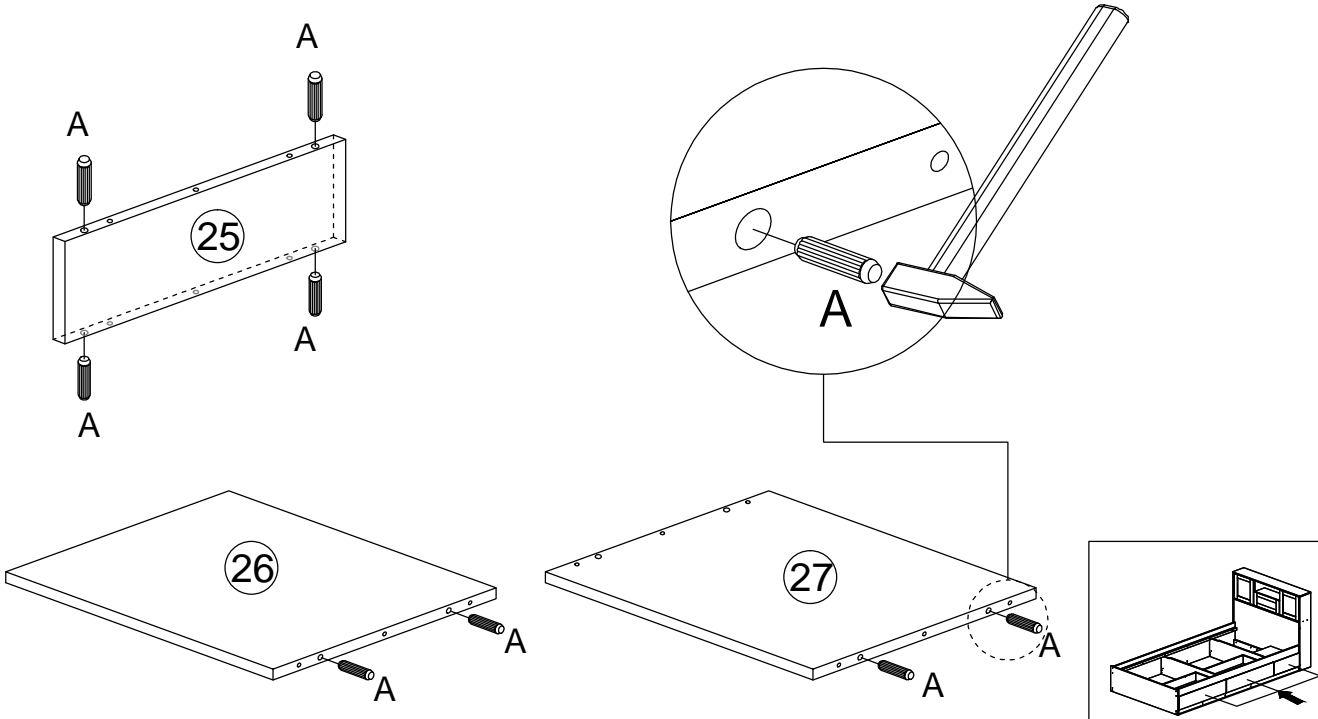
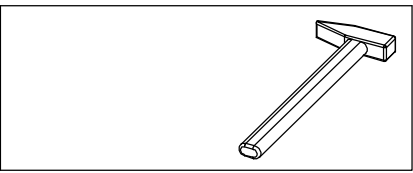

14

Fx20  
M6x11mm

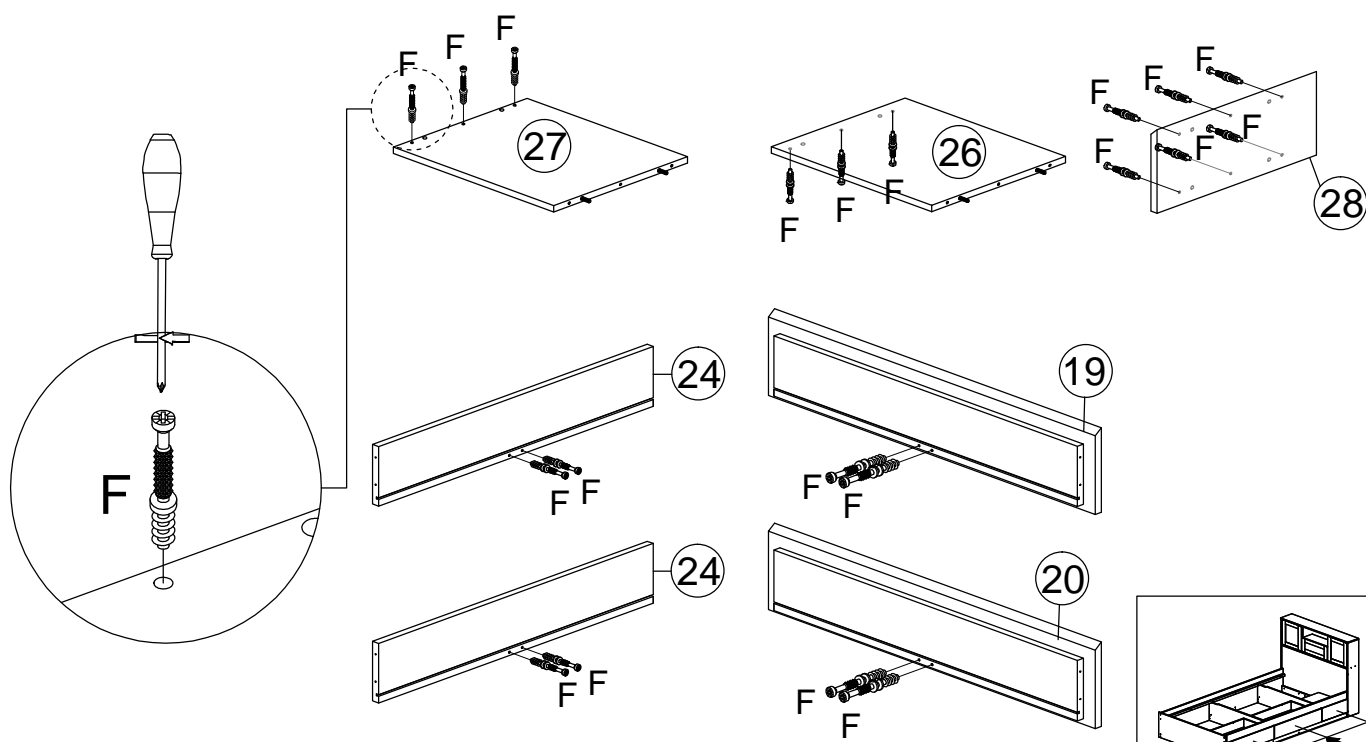
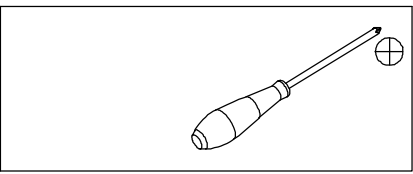

15

Cx8  
M4x38mm

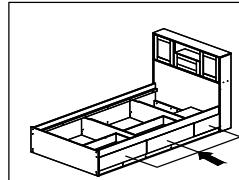
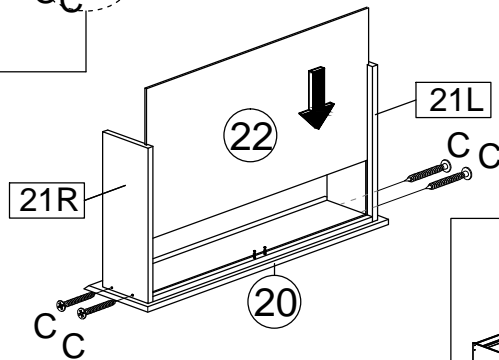
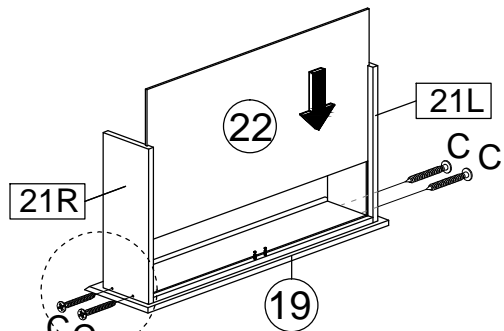
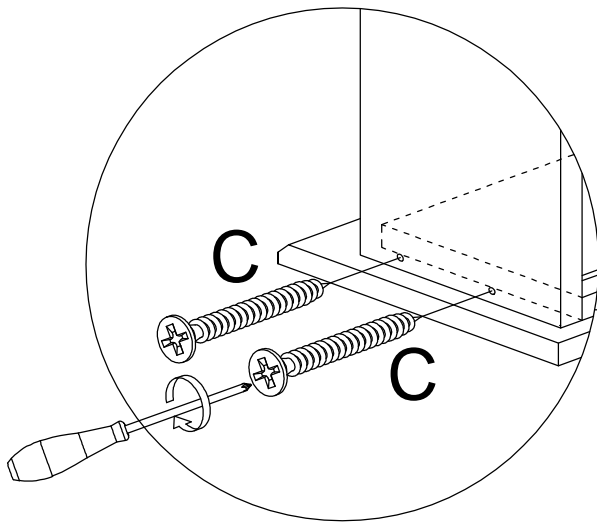
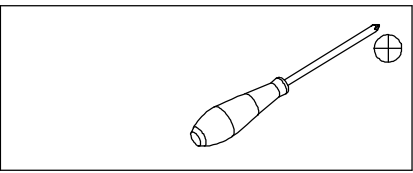

16

Ex8  
Ø15mm  
Gx8  
Ø15mm  
Kx1  
M4x64mm

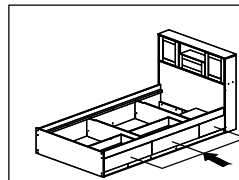
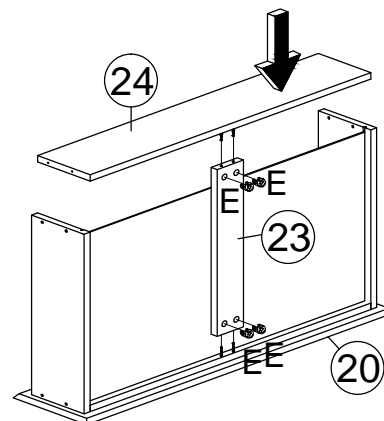
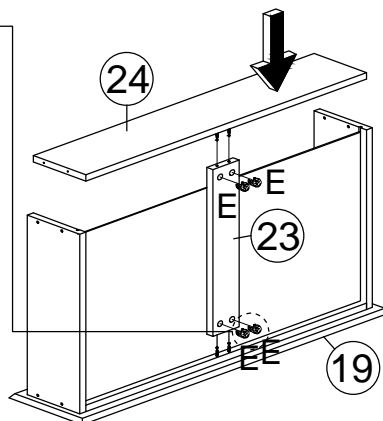
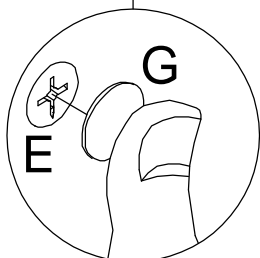
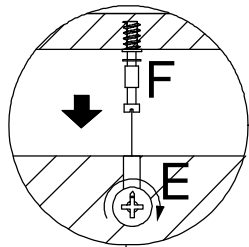

17

Cx8



M4x38mm

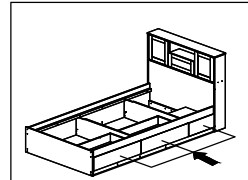
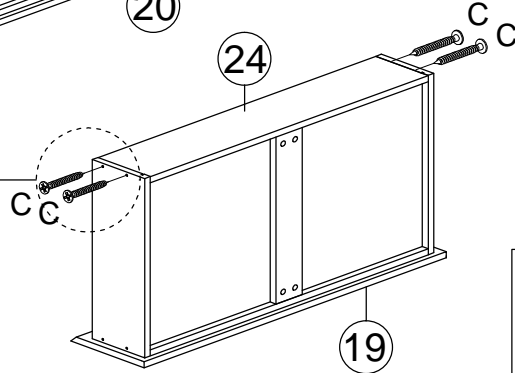
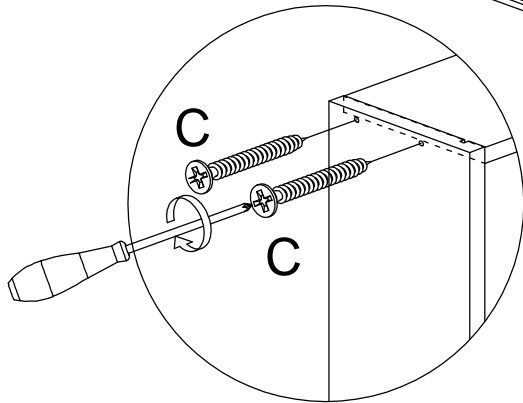
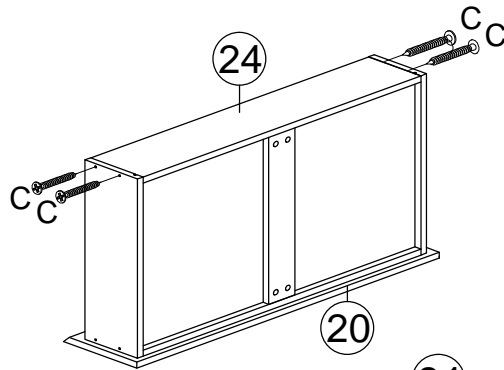
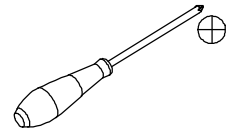

18

Bx12



M3.5x16mm

Mx1

DL



450mm (18")

Mx1



DR

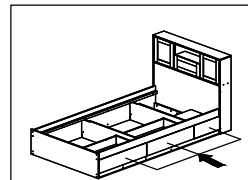
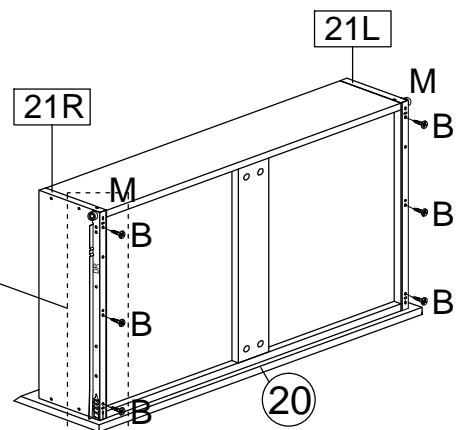
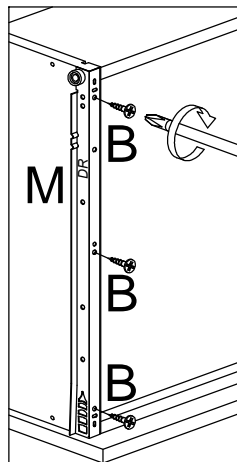
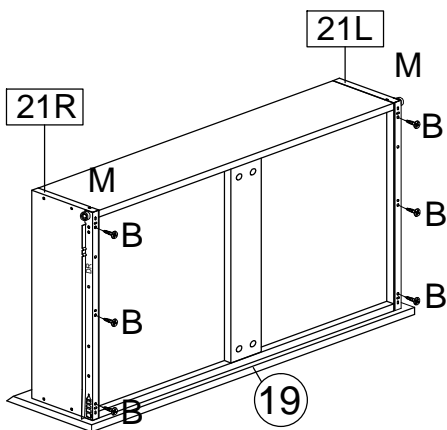
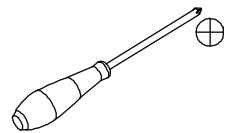

450mm (18")



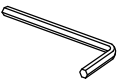

19

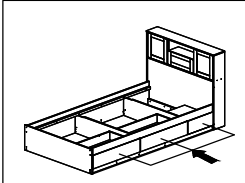
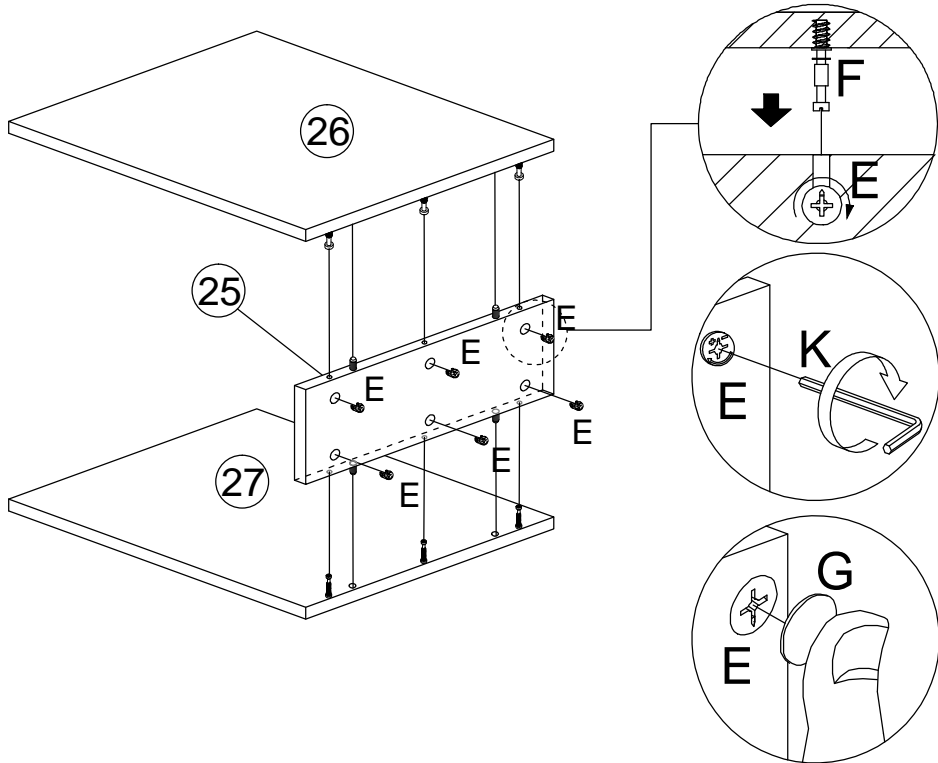
Ex6  Ø15mm	Gx6  Ø15 mm	Kx1  M4x64mm	
---	--	---	--



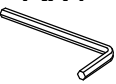

20

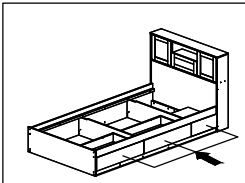
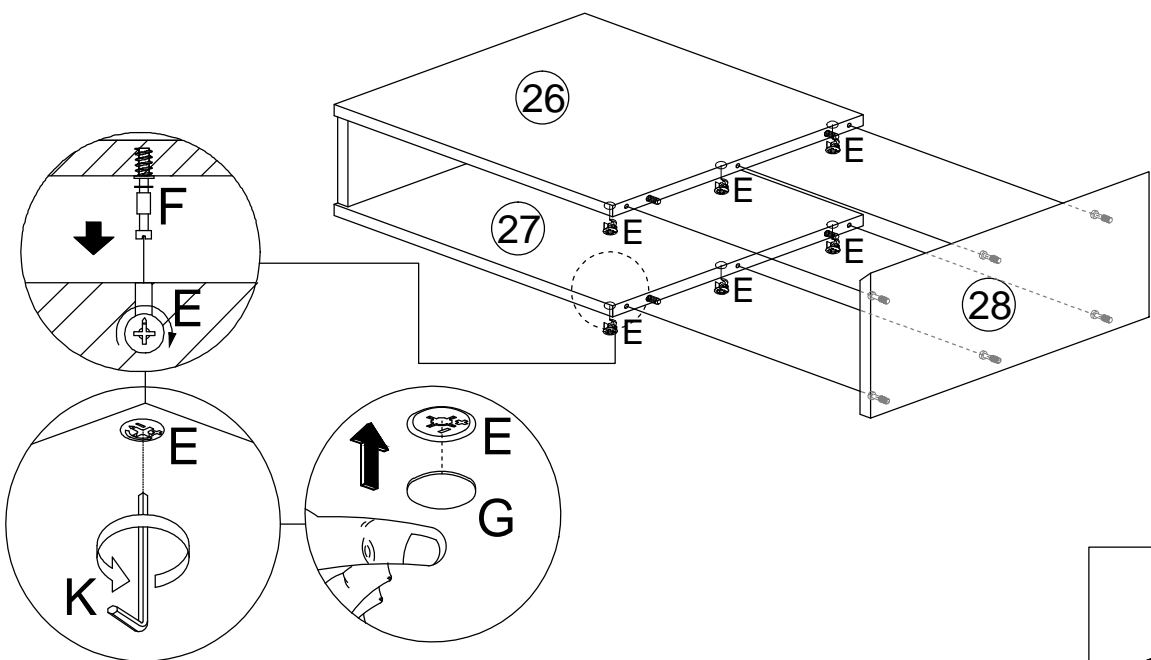
Ex6  Ø15mm	Gx6  Ø15 mm	Kx1  M4x64mm	
---	--	---	--



21

<b>Bx6</b>  M3.5x16mm	<b>Lx1</b> DL1  400mm (16")	<b>Lx1</b> DR1  400mm (16")
--	---	---

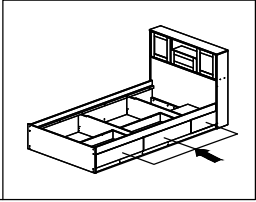
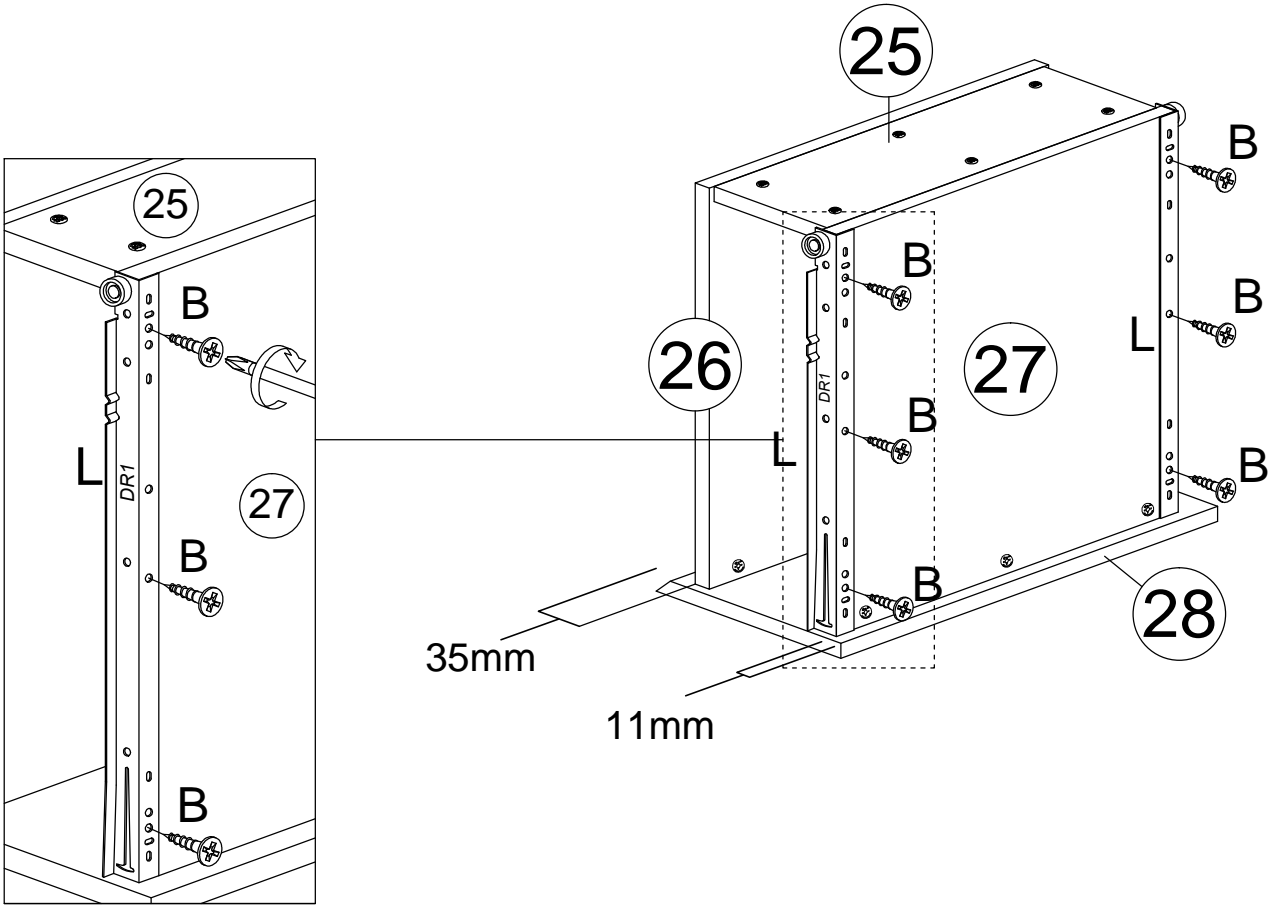
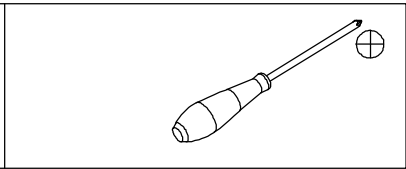

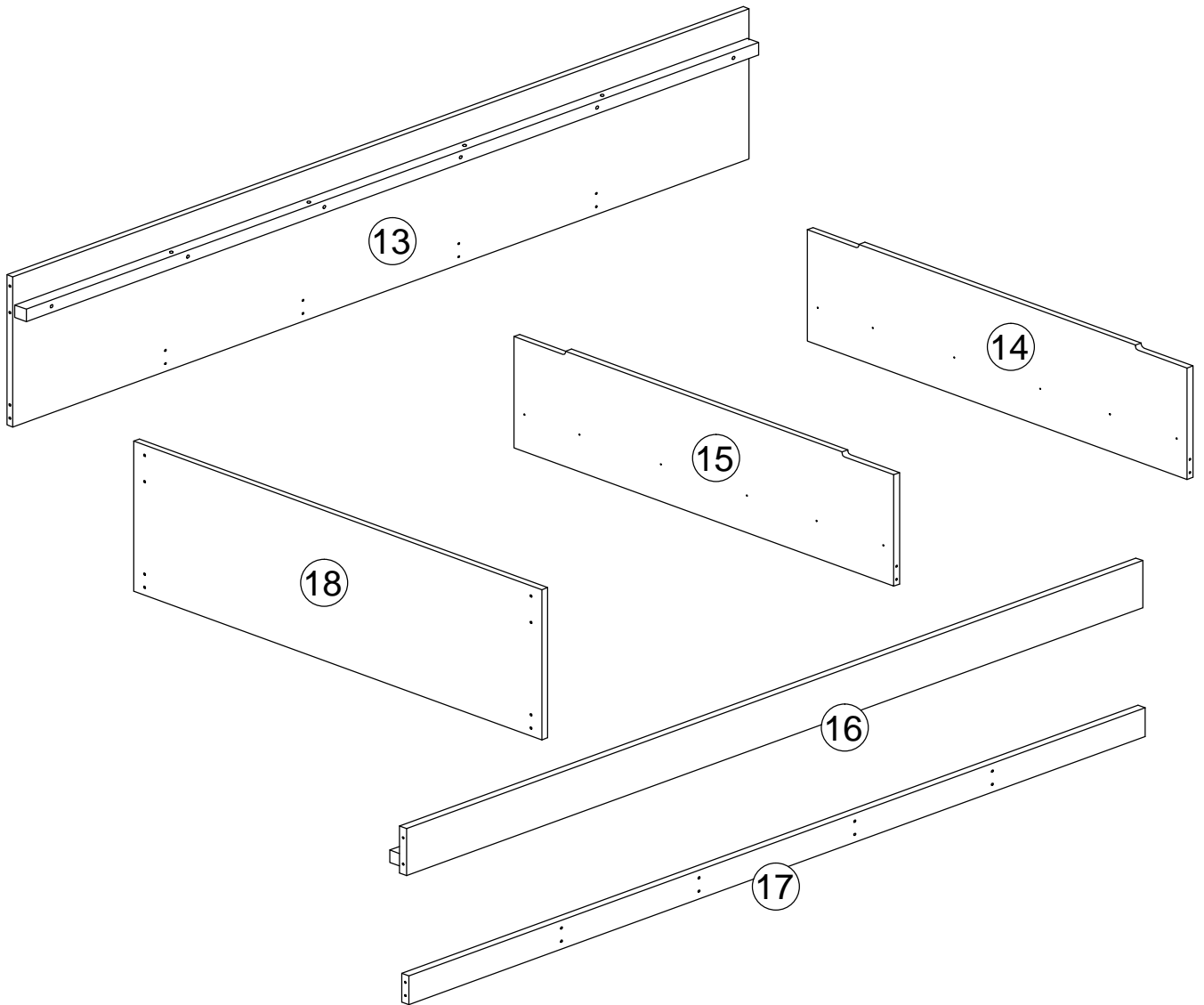
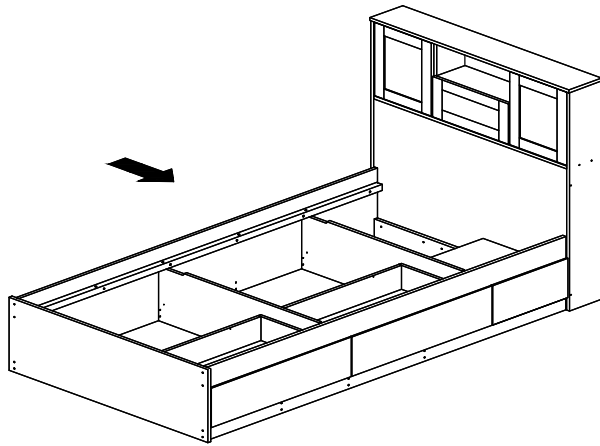

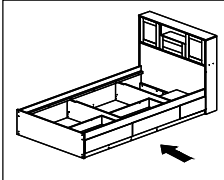
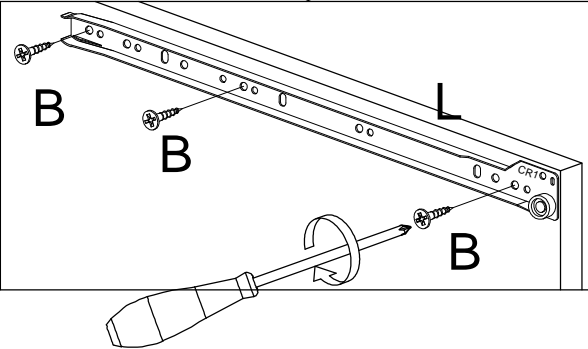
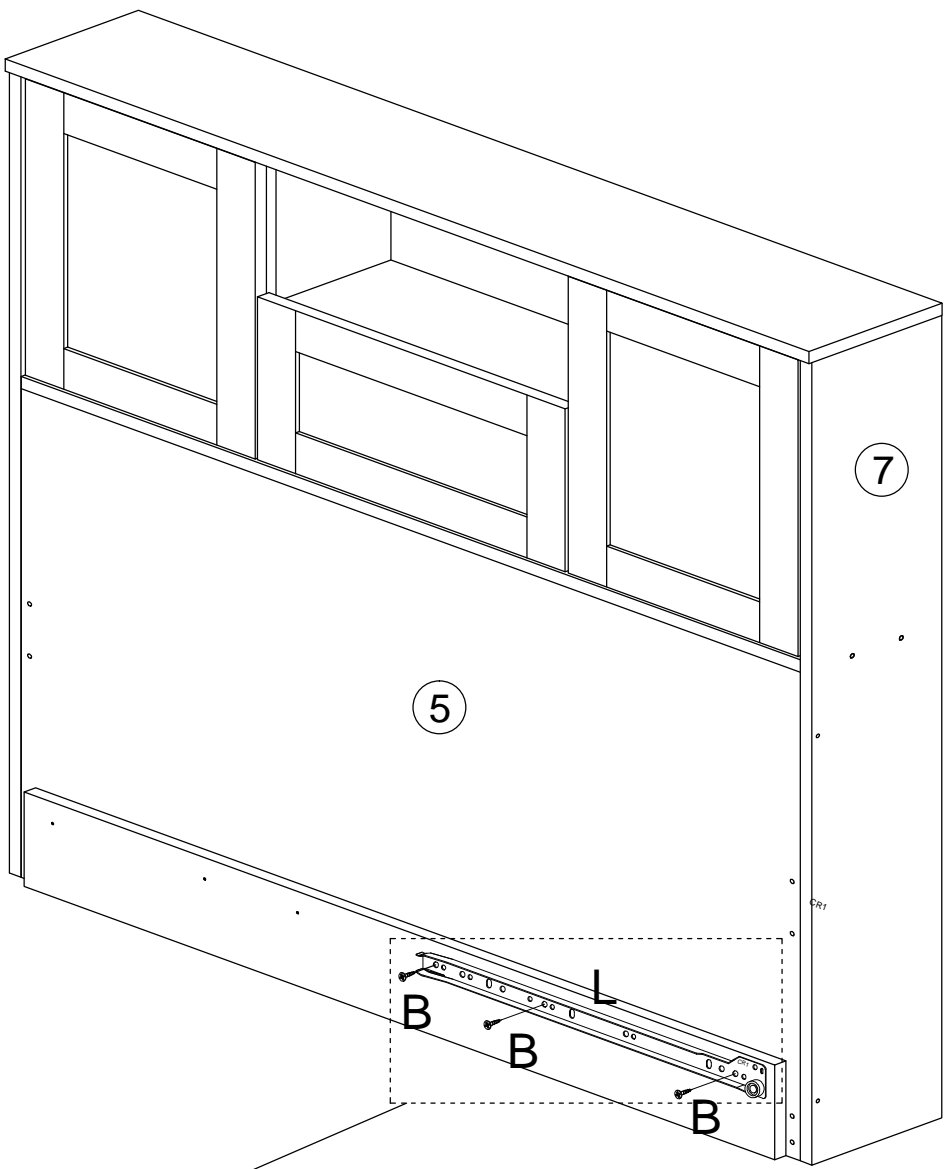

22

<b>Bx3</b>  <b>M3.5x16mm</b>	<b>Lx1</b> CR1  <b>400mm (16")</b>	
---	--	---



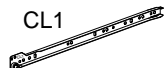

23

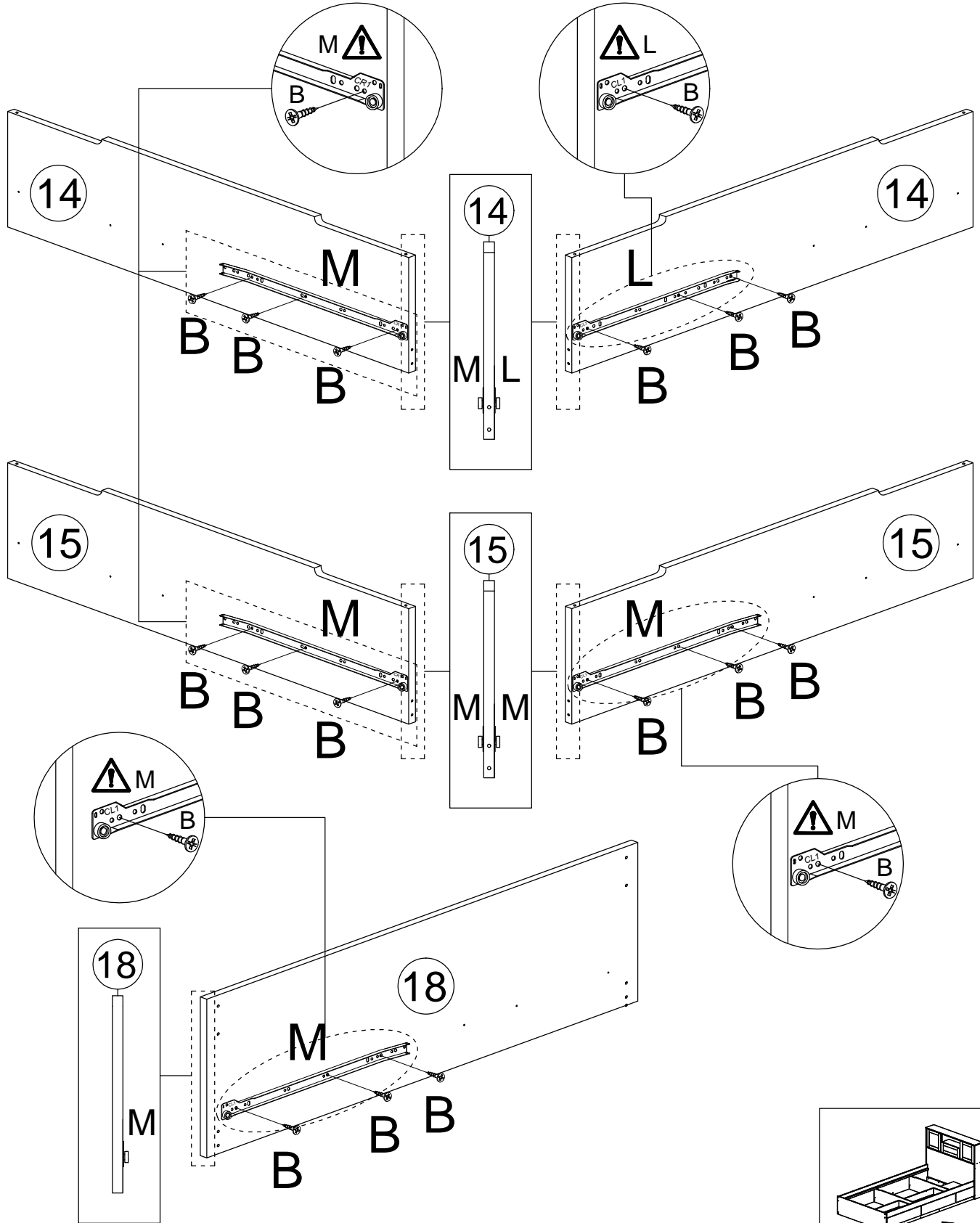
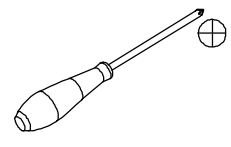
Bx15  M3.5x16mm	Lx1 CL1  400mm (16")	Mx2 CL1  450mm (18")	Mx2 CR1  450mm (18")
--	--	--	---



24

Dx12  M6x50mm	Gx16  Ø15 mm	Kx1  M4x64mm
--	---	---

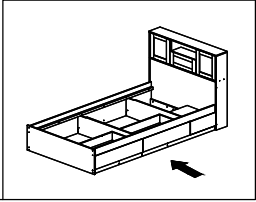
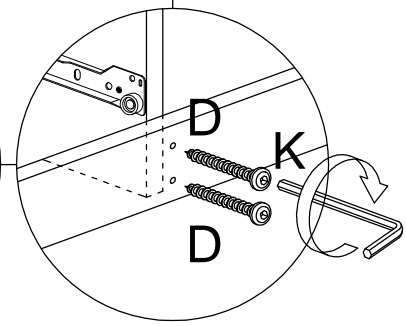
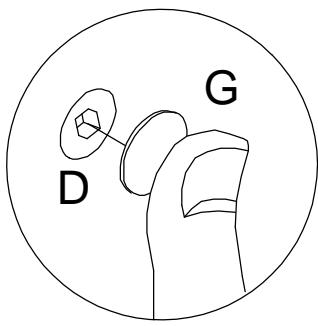
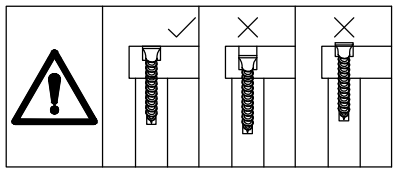
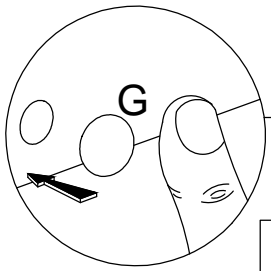
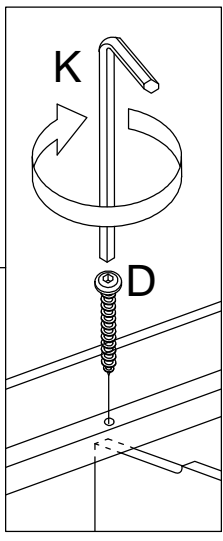
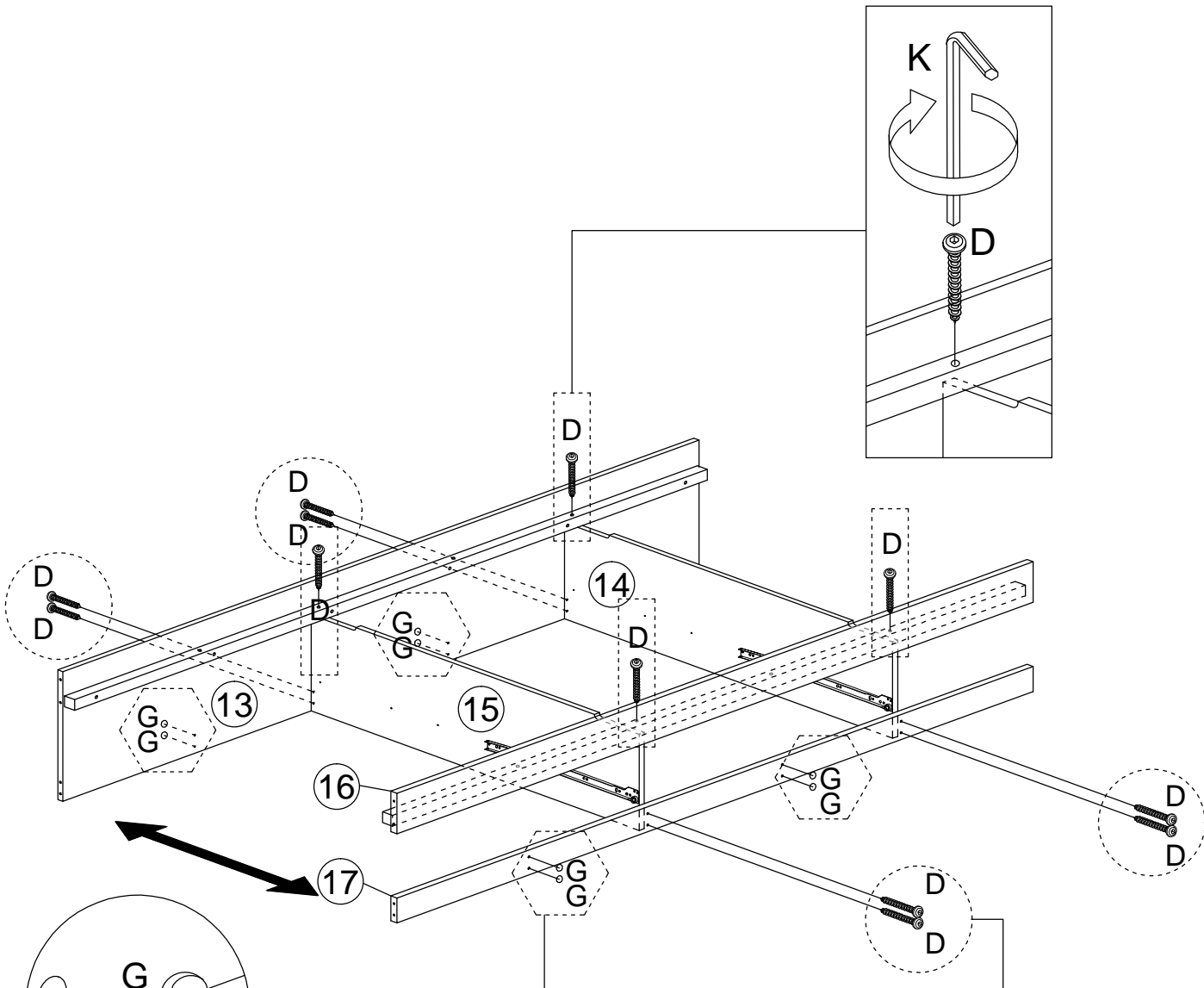
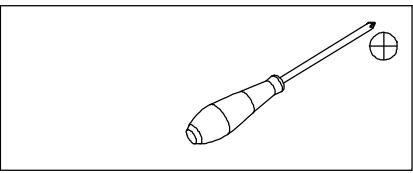

25

Dx8

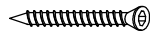

M6x50mm

Gx8



Ø15 mm

Kx1

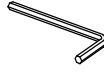

M4x64mm

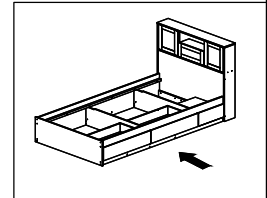
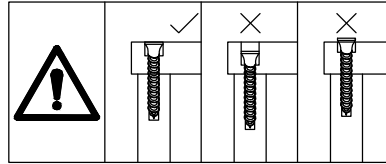
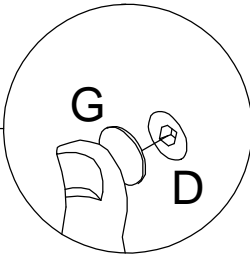
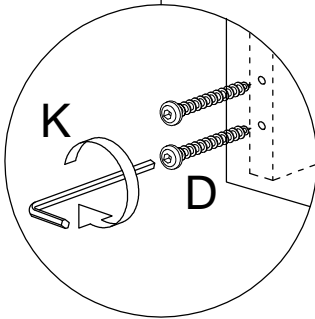
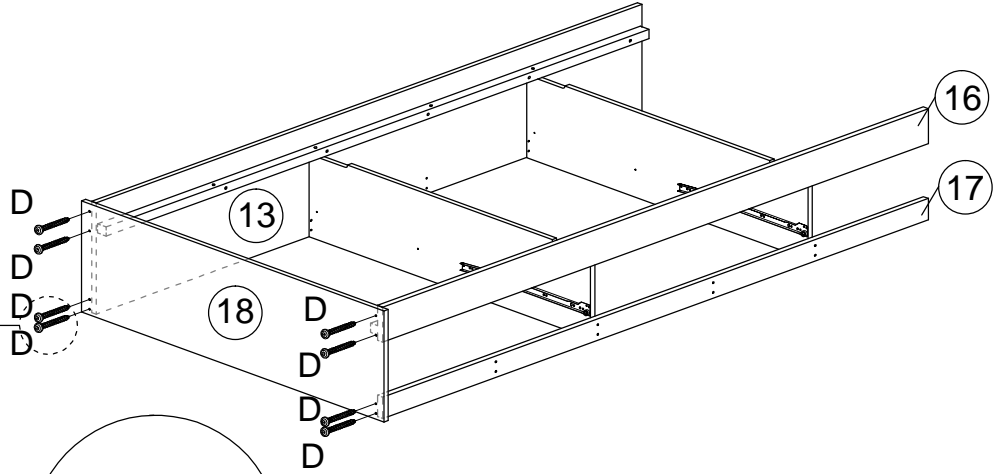

26

Dx8

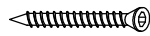

M6x50mm

Gx8



Ø15 mm

Kx1

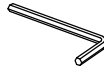

M4x64mm

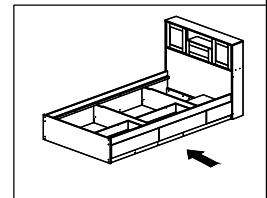
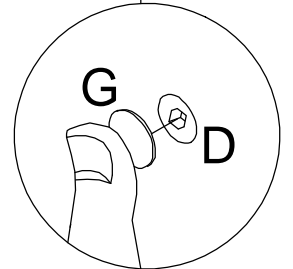
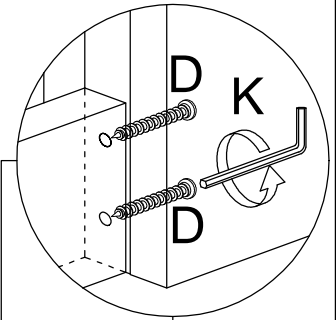
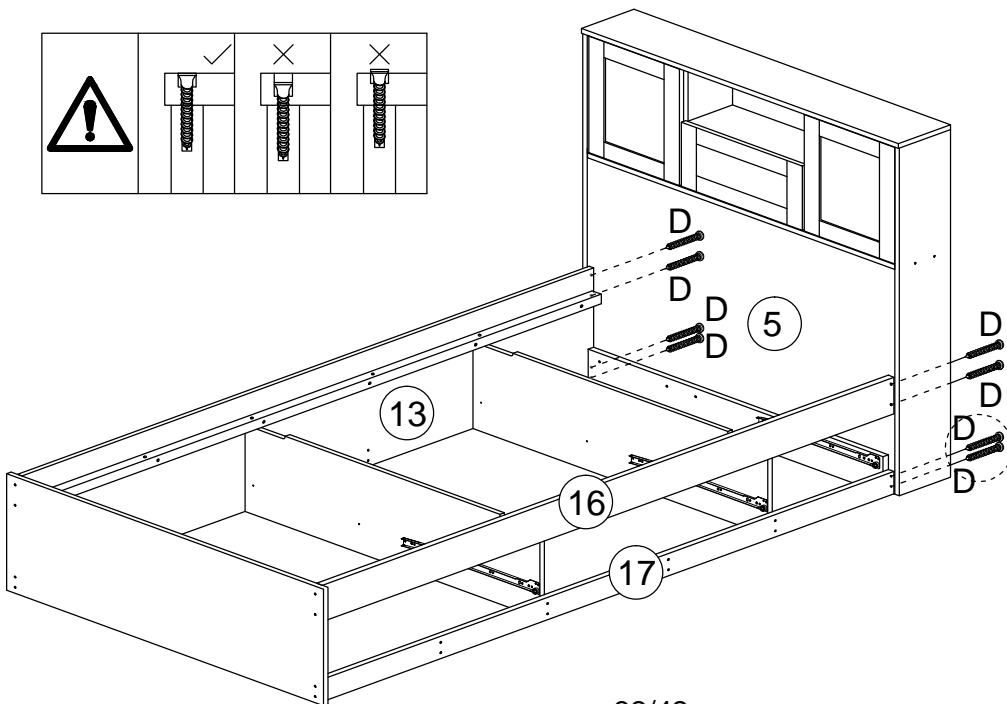
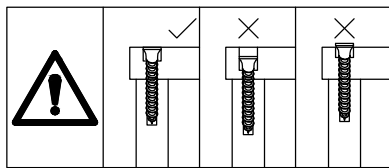

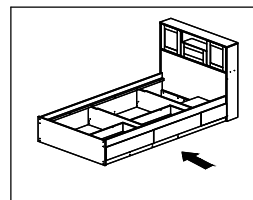
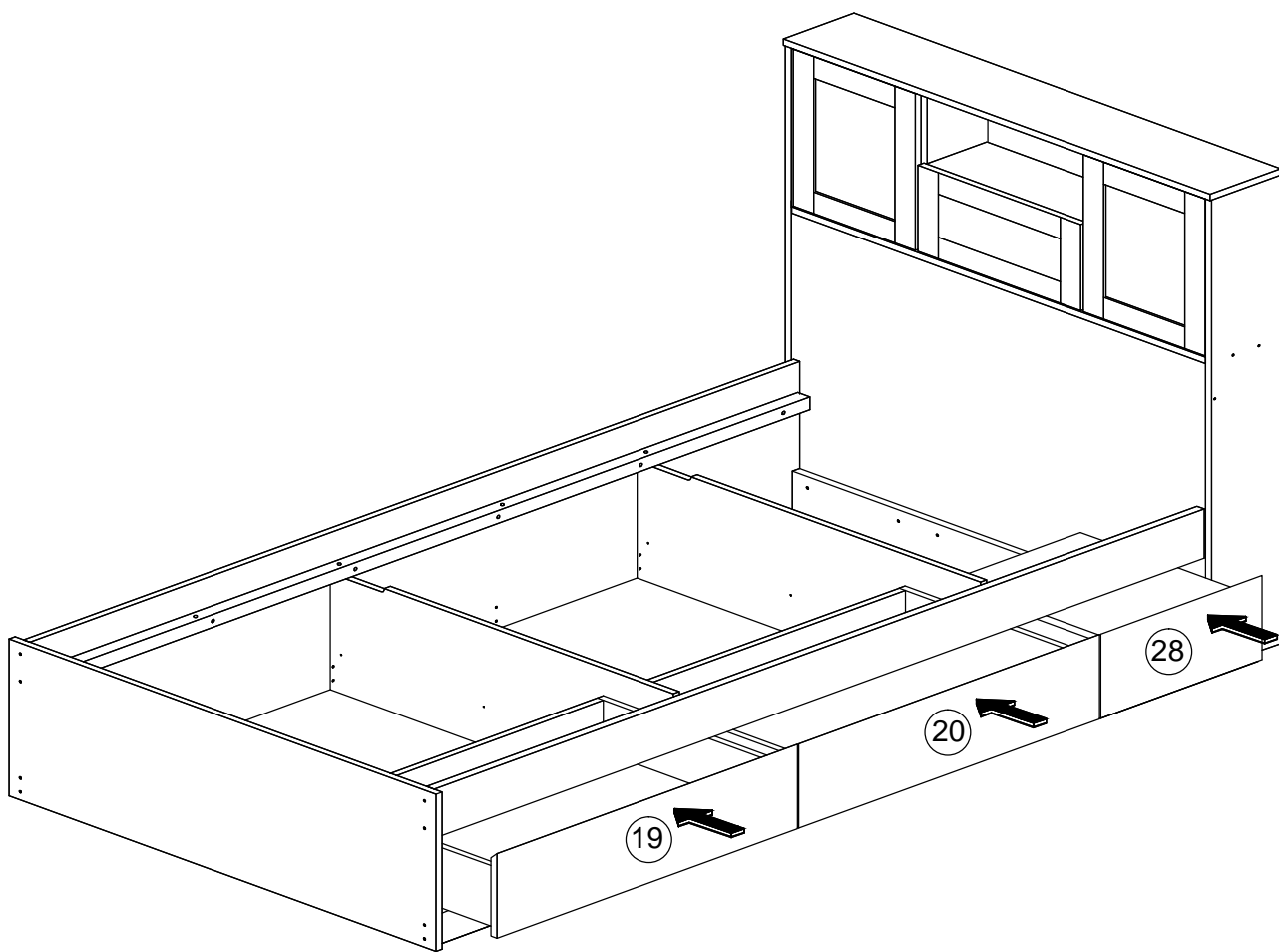

27

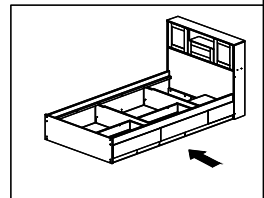
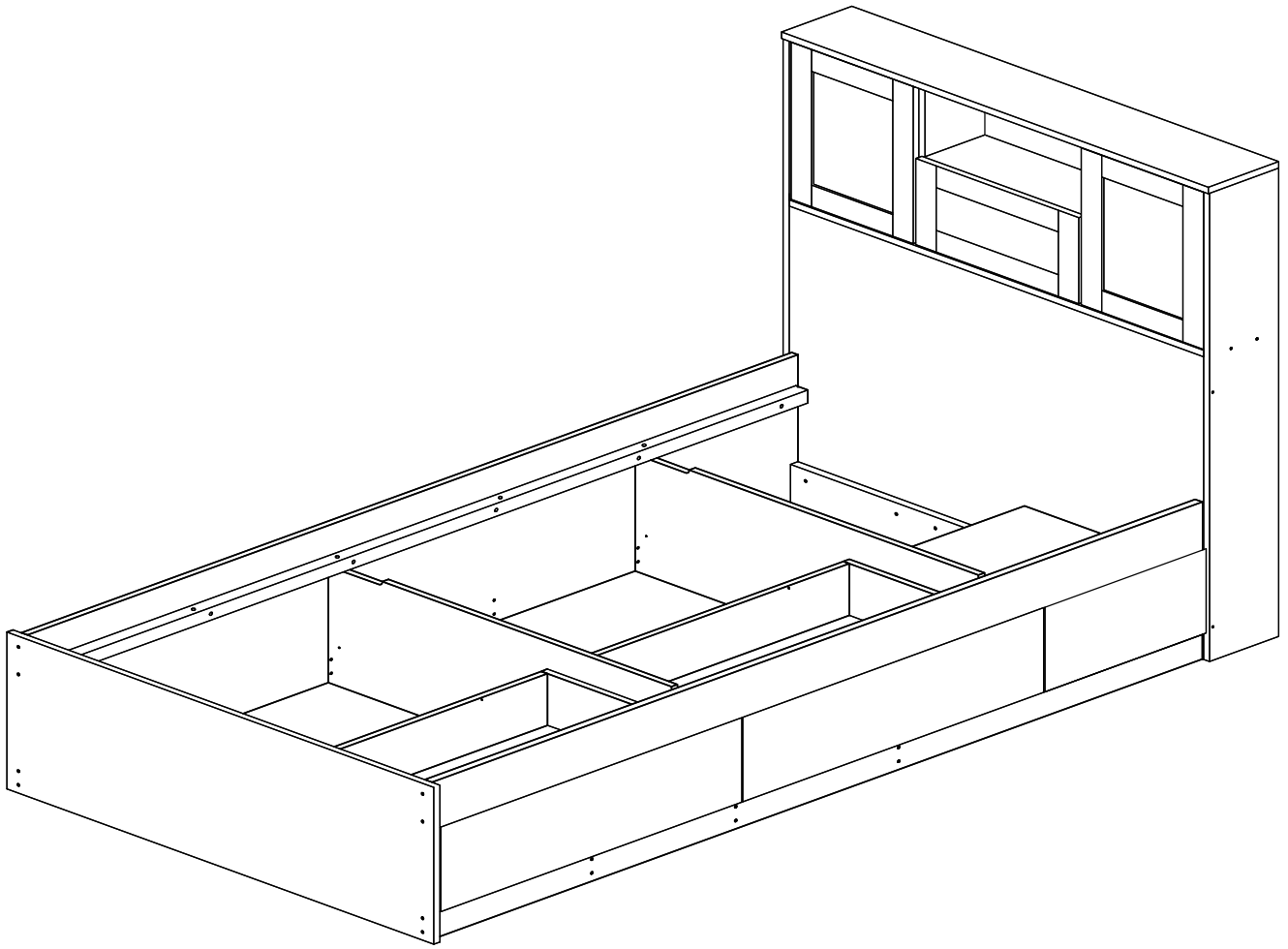

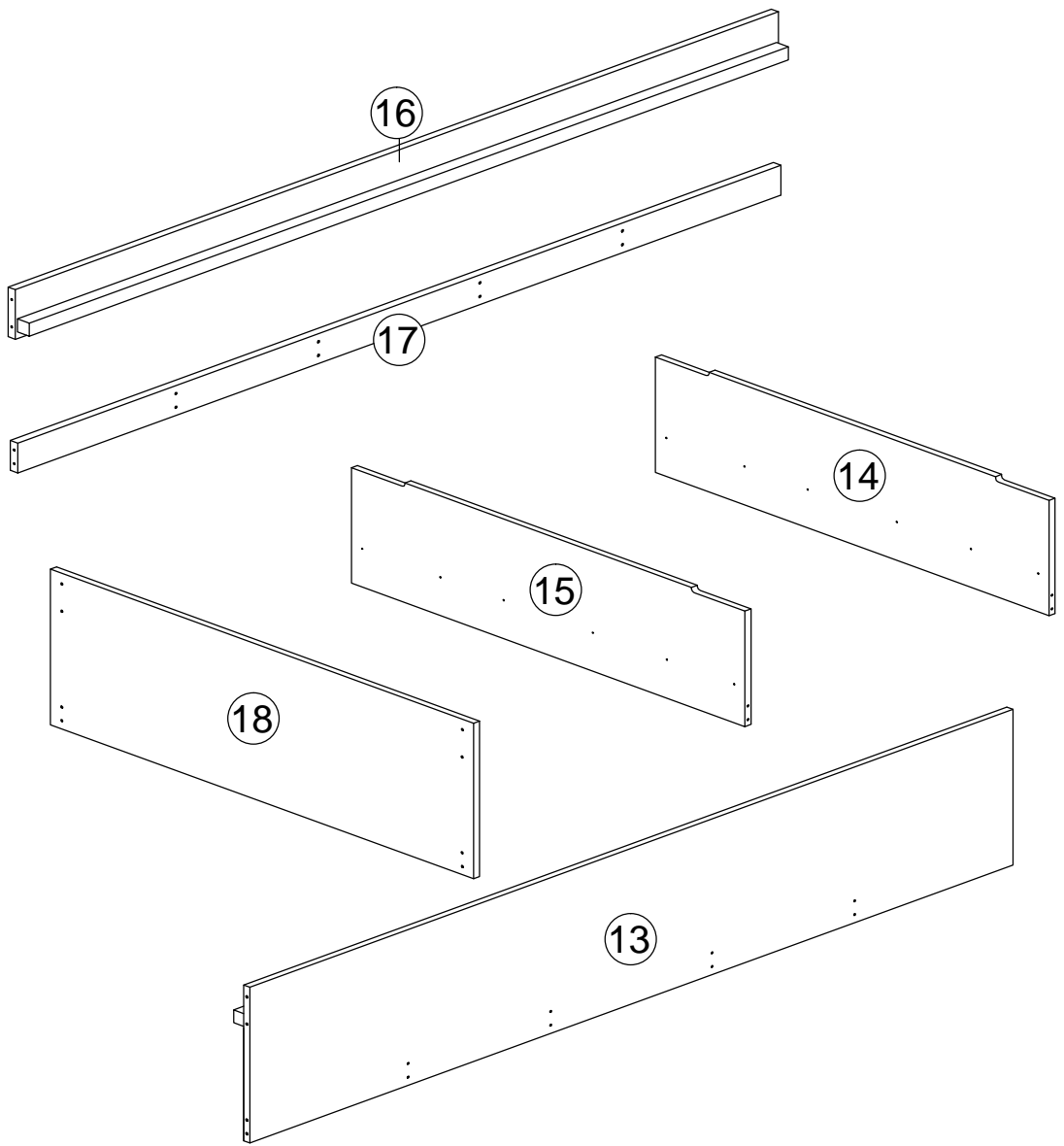
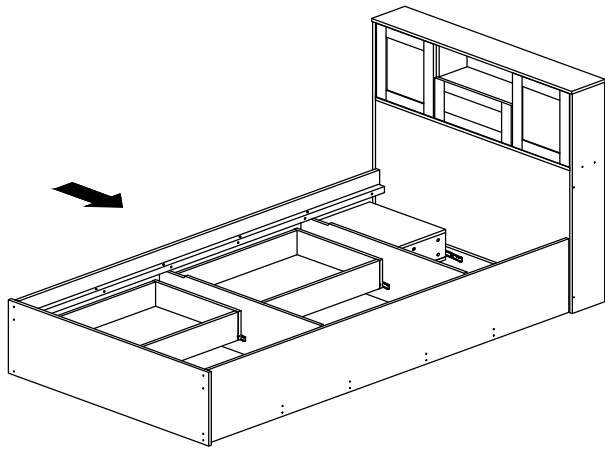





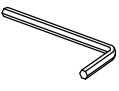

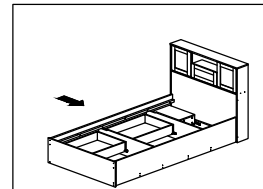
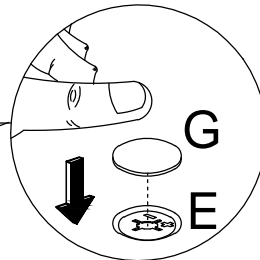
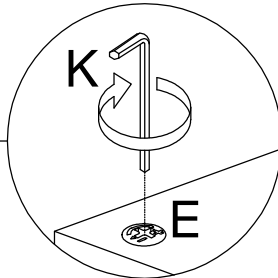
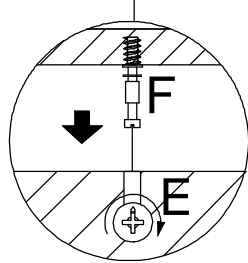
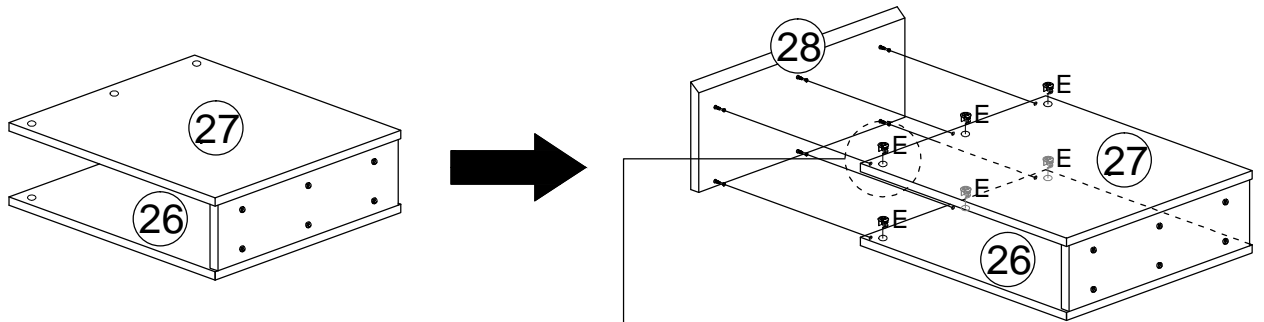
28

<b>Ex6</b>  Ø15mm	<b>Gx6</b>  Ø15 mm	<b>Kx1</b>  M4x64mm	
--	---	--	--

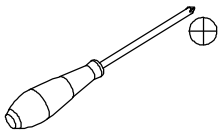

29

<b>Bx6</b>  M3.5x16mm	<b>Lx1</b> DL1  400mm (16")	<b>Lx1</b> DR1  400mm (16")	
--	---	---	---

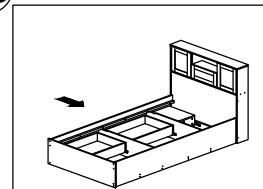
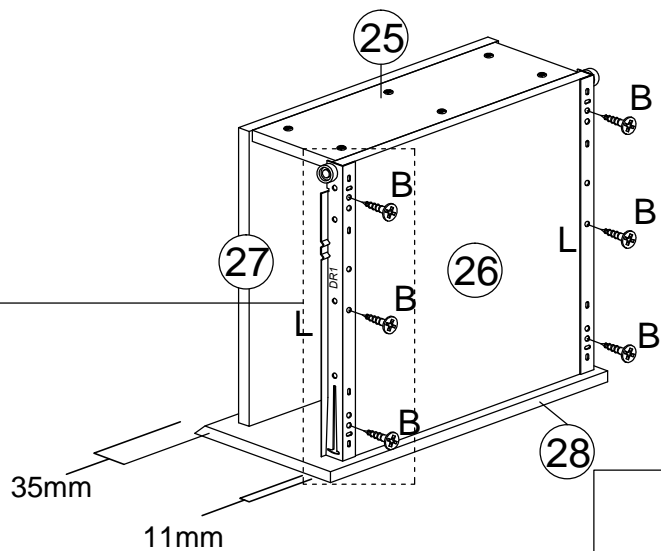
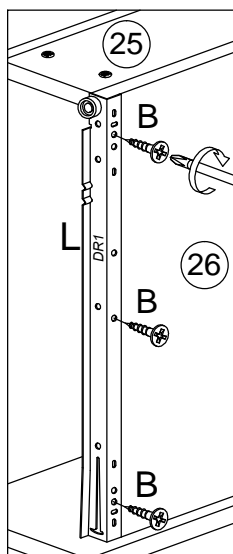

30

Bx3



M3.5x16mm

Lx1

CL1

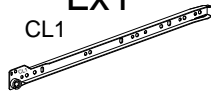

400mm (16")

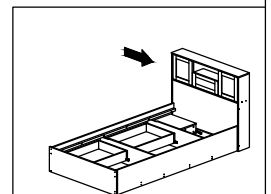
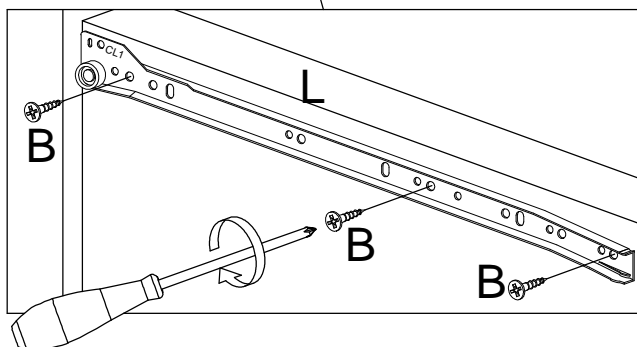
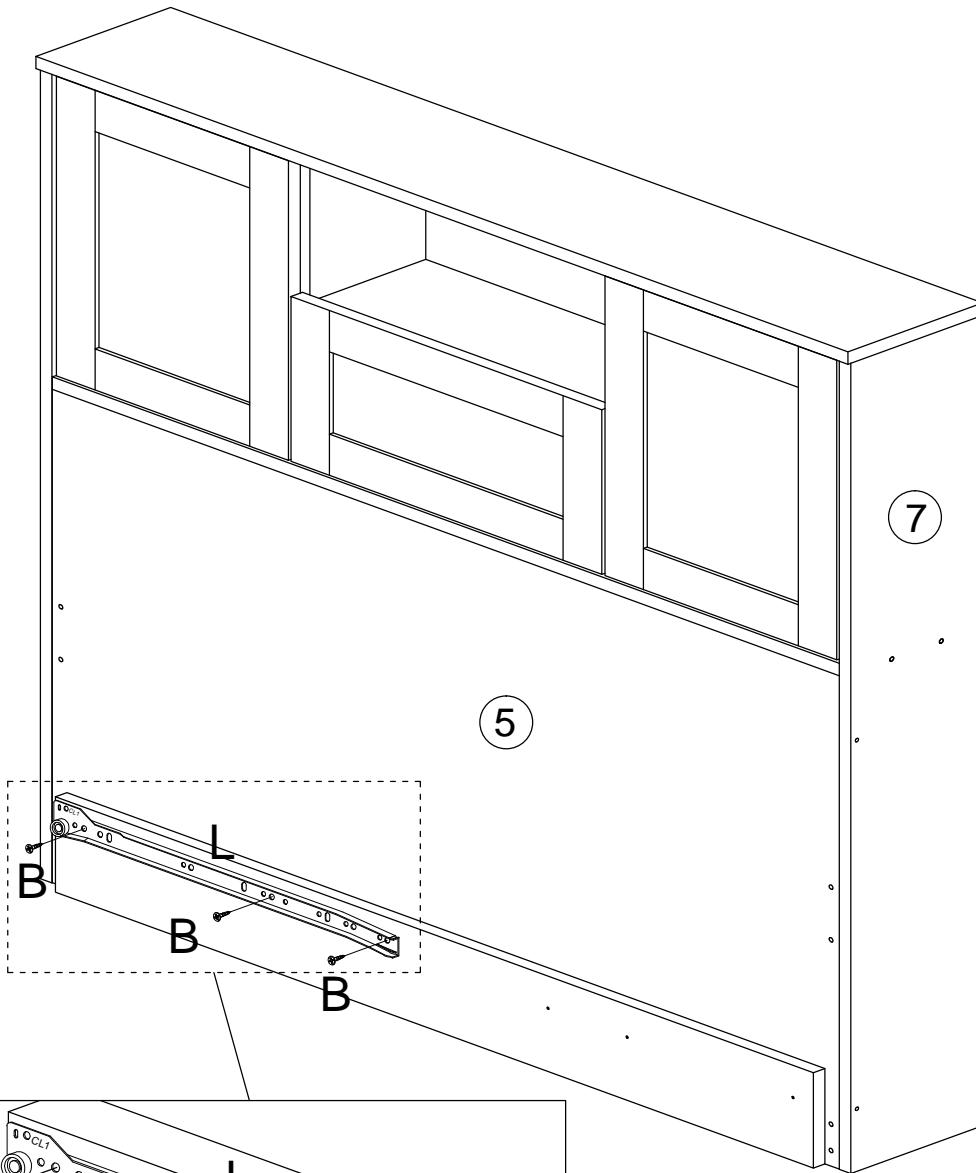
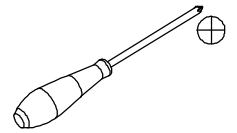

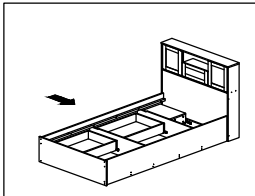
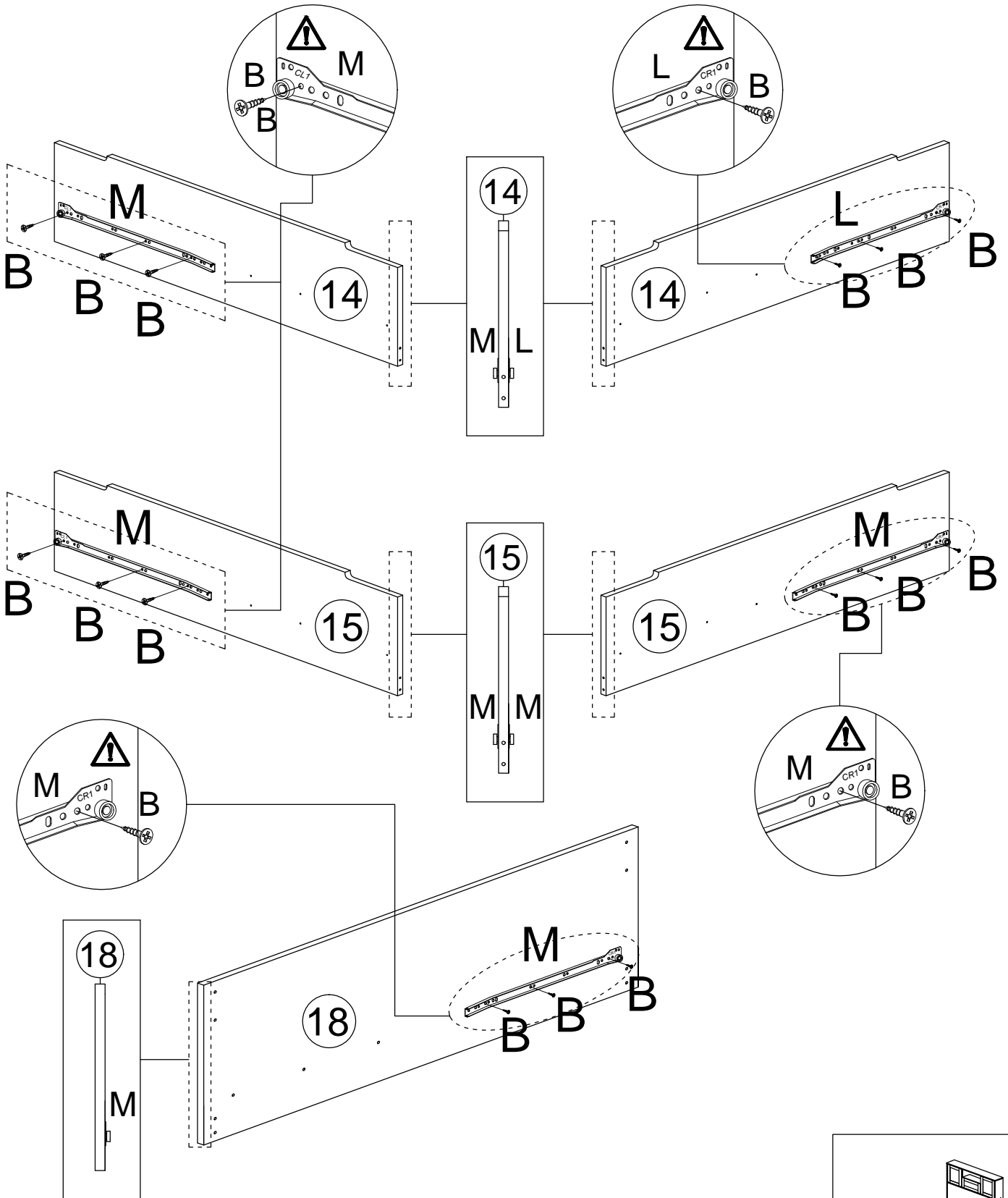
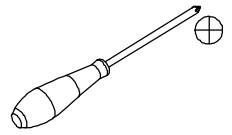

31

Bx15 Lx1 Mx2 Mx2  
CR1 CL1 CR1 CR1  
M3.5x16mm 400mm (16") 450mm (18") 450mm (18")

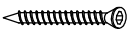

32

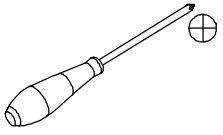
Dx12  M6x50mm	Gx16  Ø15 mm	Kx1  M4x64mm	
--	---	---	---

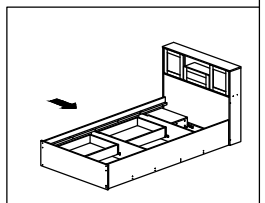
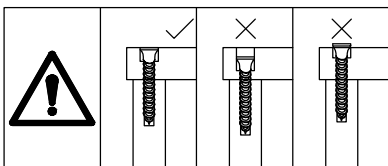
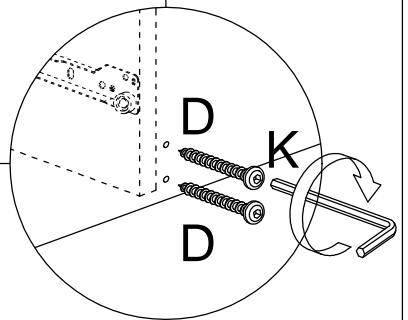
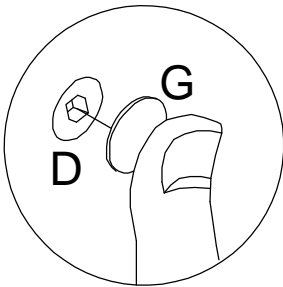
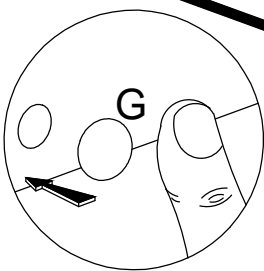
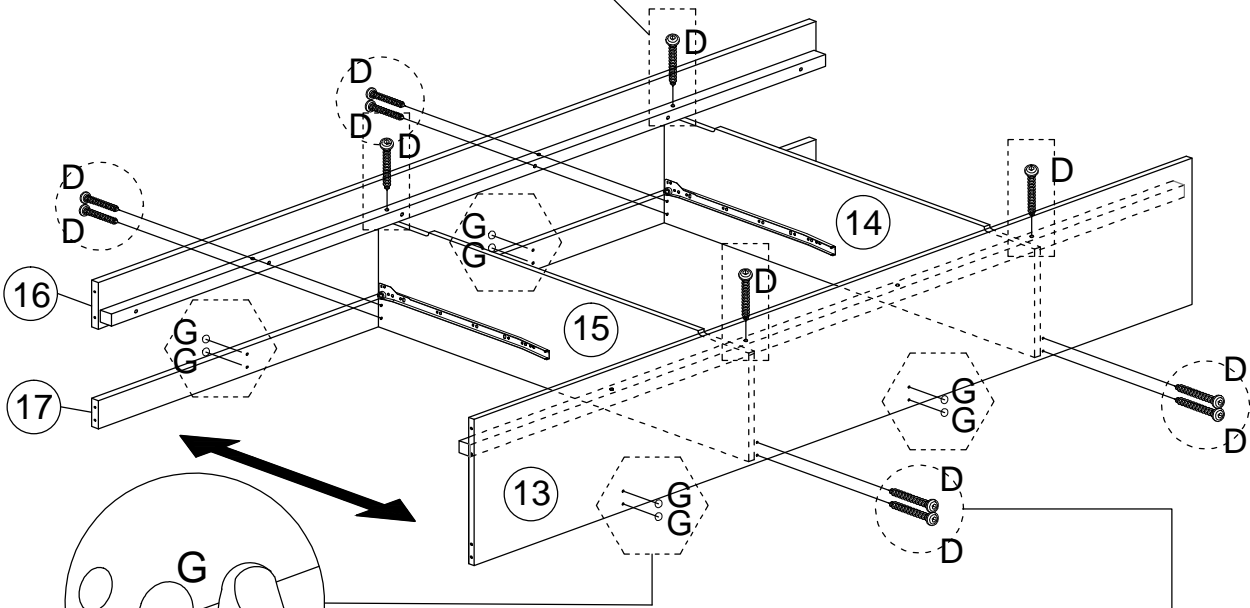
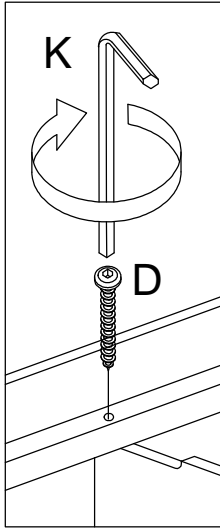

# 33

Dx8

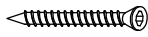

M6x50mm

Gx8



Ø15 mm

Kx1

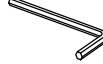

M4x64mm

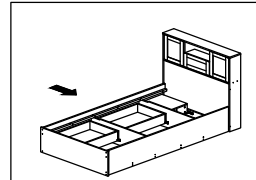
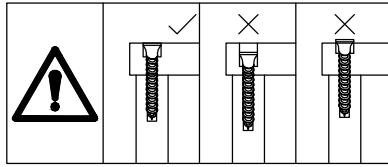
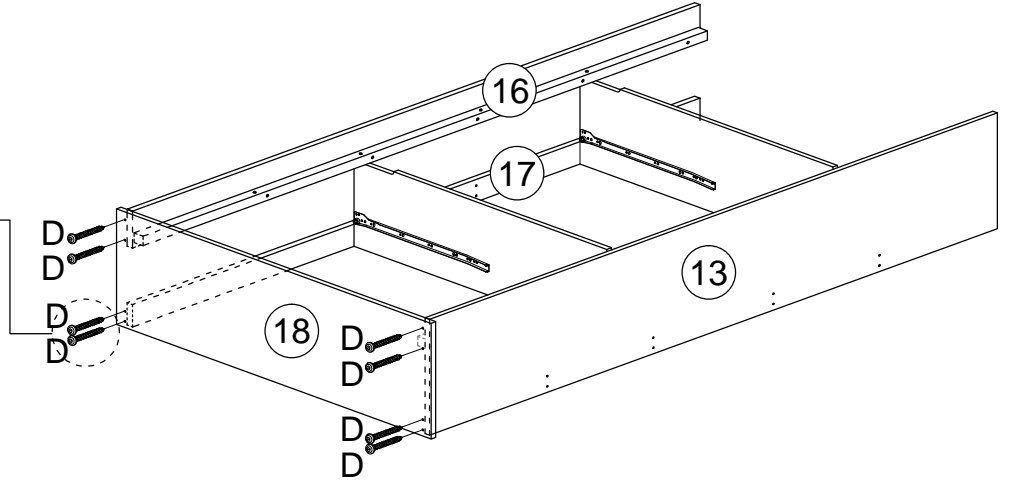
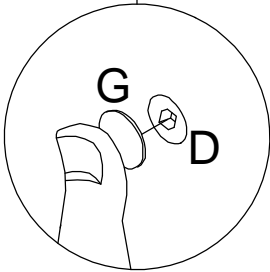
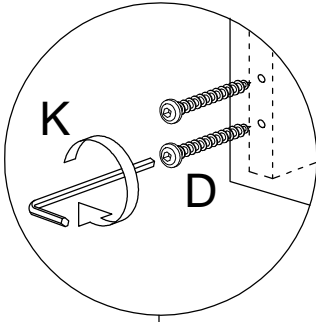

# 34

Dx8

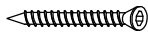

M6x50mm

Gx8



Ø15 mm

Kx1

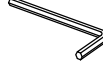

M4x64mm

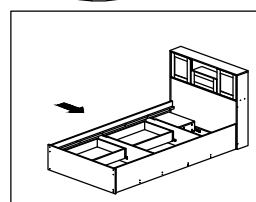
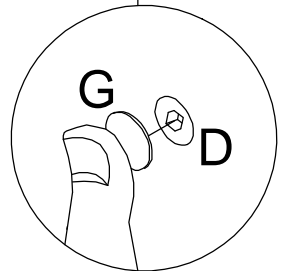
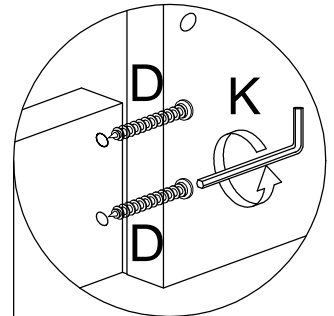
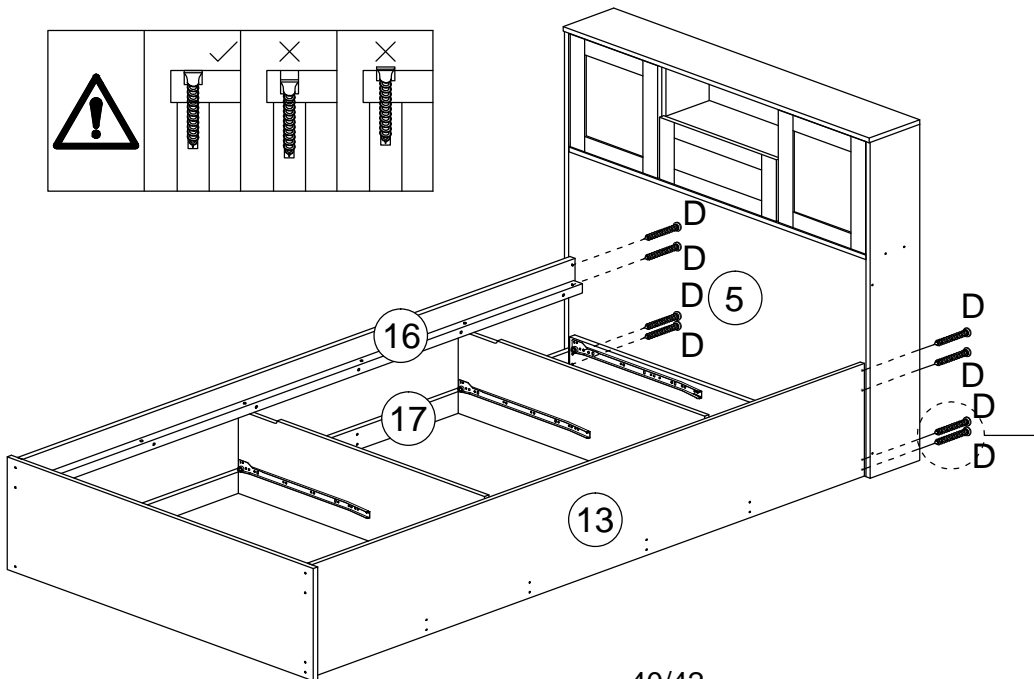
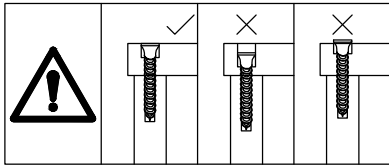

35

