

SOLBERG

129983 / 726-23-1287
136408 / 726-25-1120

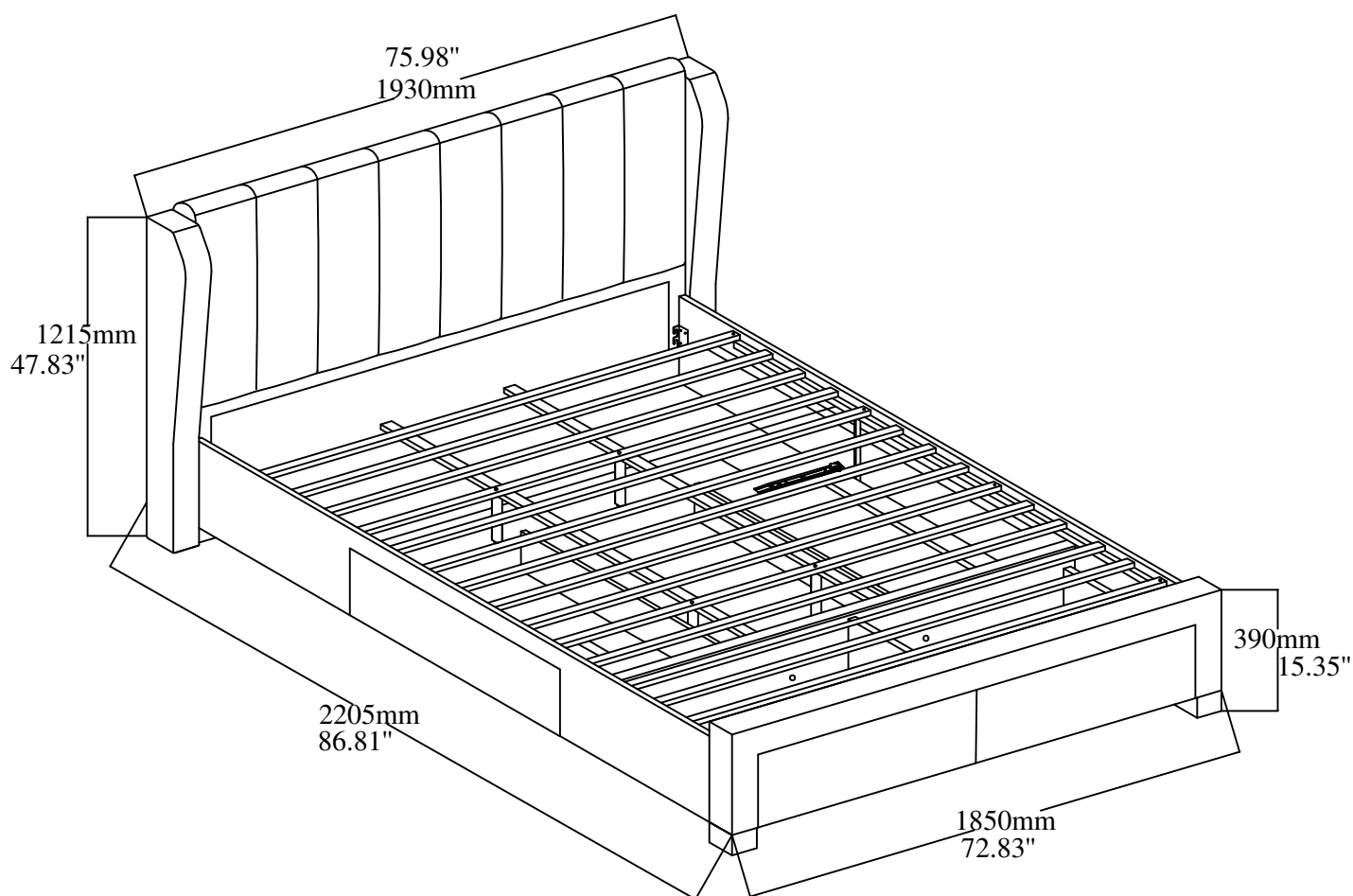

08.07.2025 - REV 2



JYSK.com

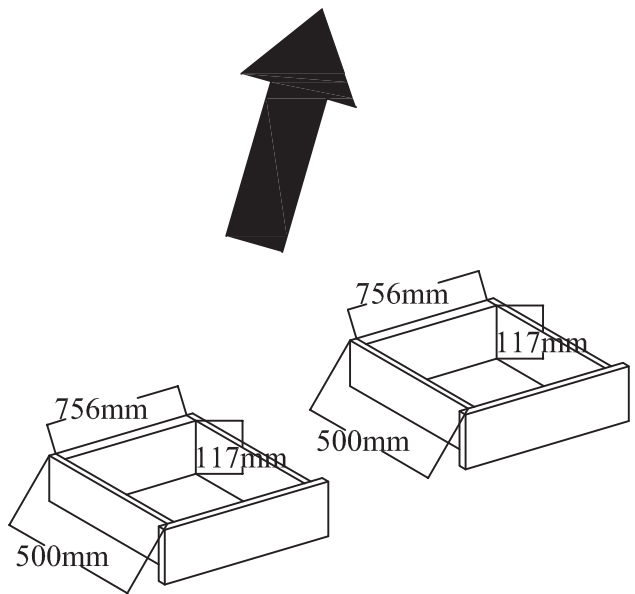
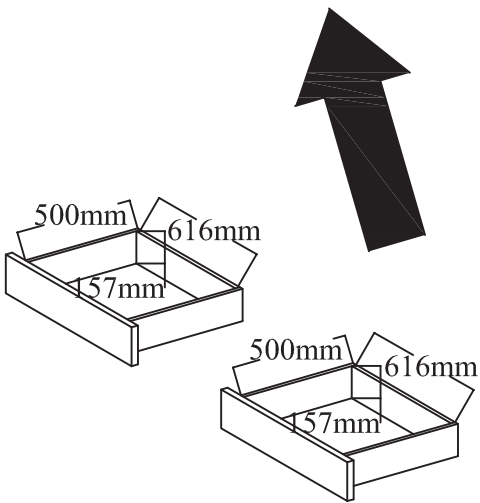
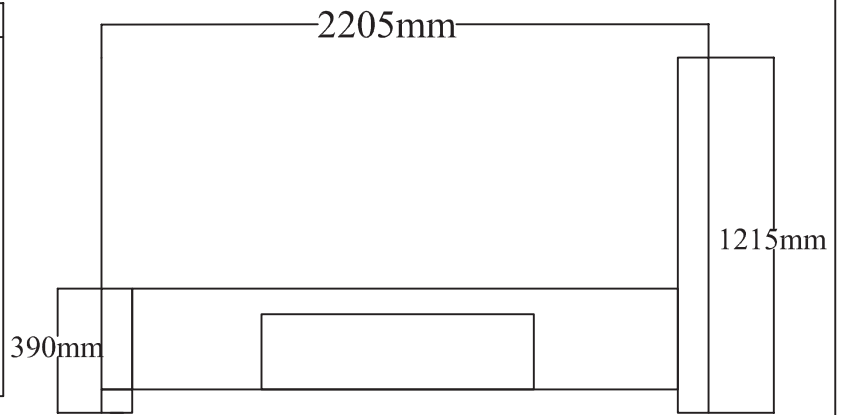
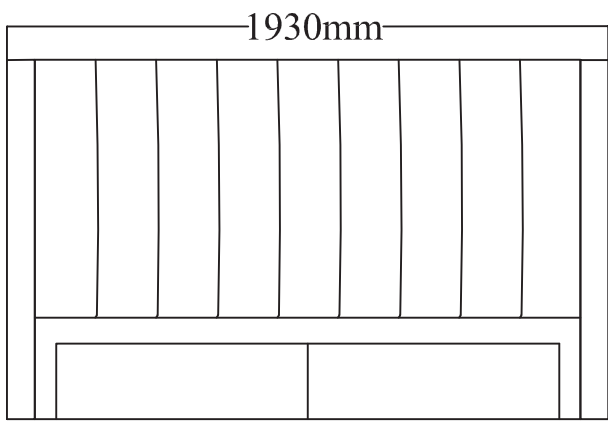
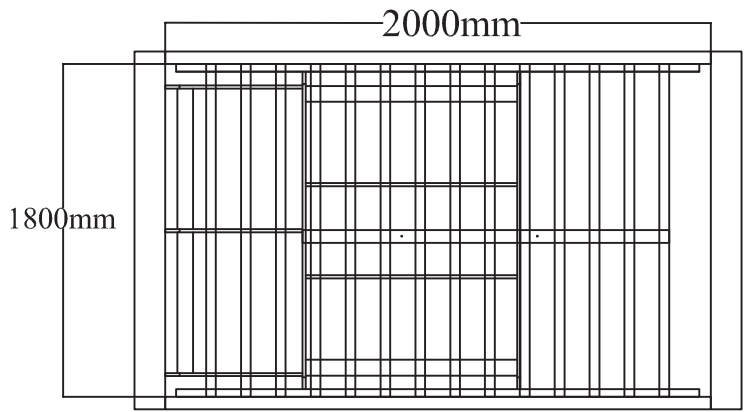

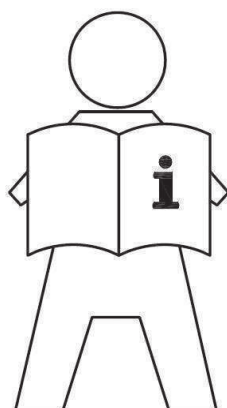

EN: IMPORTANT INFORMATION!

Please read the entire manual carefully before starting to assemble and/or using this product. Follow the manual thoroughly and keep it for further reference.

FR: INFORMATIONS IMPORTANTES

Veillez lire attentivement l'ensemble du manuel avant de commencer à monter et/ou utiliser ce produit. Suivez rigoureusement le manuel et conservez-le pour toute consultation ultérieure.

LV: SVARĪGA INFORMĀCIJA!

Pirms šī izstrādājuma montāžas un/vai lietošanas uzsākšanas pilnībā izlasiet lietošanas pamācību. Stingri ievērojiet pamācības norādījumus un saglabājiet to turpmākai lietošanai.

LT: SVARBI INFORMACIJA!

Prieš pradėdami montuoti gaminį ir (arba) juo naudotis, prašome atidžiai perskaityti visą vadovą. Atidžiai skaitykite vadovą ir turėkite jį su savimi, kad galėtumėte toliau vadovautis jo nuorodomis.

EE: OLULINE TEAVE!

Enne kui alustate toote kokku panemist ja/või kasutamist, lugege see kasutusjuhend hoolikalt läbi. Järgige täpselt juhendis toodud juhiseid ja hoidke juhend alles.

RU: ВАЖНАЯ ИНФОРМАЦИЯ!

Внимательно и полностью прочитайте это руководство, прежде чем приступать к сборке или использованию этого изделия. Следуйте всем инструкциям этого руководства и сохраните его на будущее для справки.

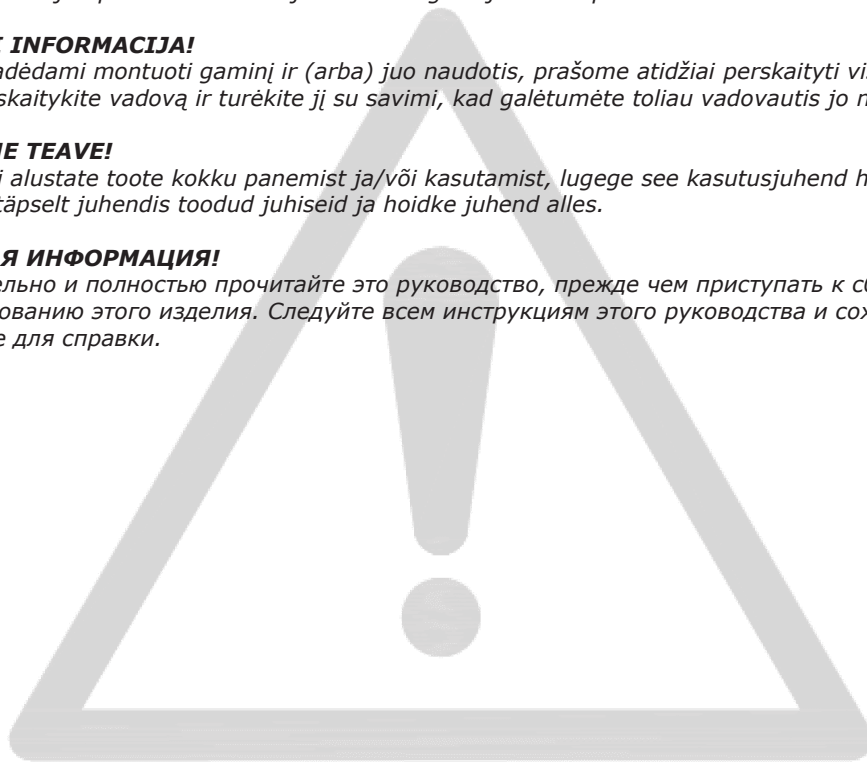

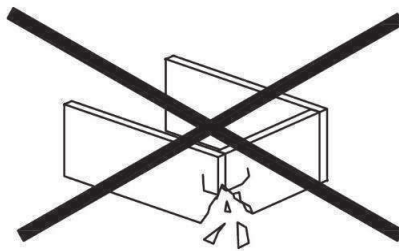
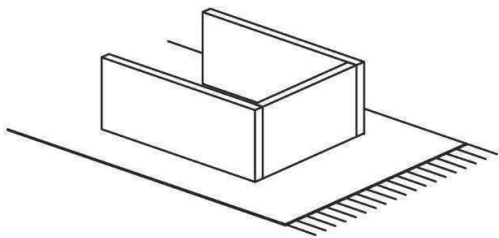

EN: WARNING TO AVOID SCRATCHES!

In order to avoid scratching this furniture should be assembled on a soft layer - could be a rug.

FR: AVERTISSEMENT POUR ÉVITER LES RAYURES

Afin d'éviter les rayures, ce meuble doit être monté sur une surface souple (un tapis, par exemple).

LV: BRĪDINĀJUMS PAR SKRĀPĒJUMIEM!

Lai nesaskrāpētu šo izstrādājumu, veiciet montāžu uz mīkstas pamatnes, piemēram, paklāja.

LT: ĮSPĖJIMAS, KAD IŠVENGTUMĖTE ĮBRĖŽIMŲ!

Šio baldo nesubraižysite, jei jį surinksite ant švelnaus paviršiaus, pavyzdžiui, kilimo.

EE: HOIATUS KRIIMUSTUSTE VÄLTIMISEKS!

Kriimustuste tekkimise vältimiseks mööblile tuleb see kokku panna pehmel pinnal, nt kaltsuvaibal.

RU: ПРЕДУПРЕЖДЕНИЕ ОТНОСИТЕЛЬНО ЦАРАПИН!

Во избежание нанесения царапин, сборку этой мебели необходимо выполнять на мягкой поверхности, например на ковре.



EN: IMPORTANT!

It is important that any product which is assembled using any kind of screw is re-tightened 2 weeks after assembly, and once every 3 months - in order to assure stability through-out the lifespan of the product.

FR: IMPORTANT

Il est important que tout produit monté à l'aide de vis soit resserré 2 semaines après son montage, puis tous les 3 mois, afin de garantir sa stabilité durant tout son cycle de vie.

LV: SVARĪGI!

Ir svarīgi, lai jebkuram produktam, kas tiek uzstādīts ar jebkādu skrūvju palīdzību, skrūves tiktu atkārtoti pievilktas 2 nedēļas pēc montāžas, pēc tam – reizi 3 mēnešos, tā nodrošinot stabilitāti visā izstrādājuma kalpošanas laikā.

LT: SVARBU!

Bet kokį varžtais tvirtinamą gaminį 2 savaites po surinkimo bei kas 3 mėnesius reikia papildomai suveržti – taip užtikrinamas naudojamo gaminio stabilumas.

EE: TÄHTIS!

Oluline on, et toote kruvisid pingutataks 2 nädalat pärast kokkupanekut ja seejärel iga 3 kuu järel, et tagada stabiilsus kogu toote eluea jooksul.

RU: ВАЖНО!

В любом изделии, собранном с использованием винтов любого типа, необходимо через 2 недели после сборки и в дальнейшем каждые 3 месяца подтягивать винты, чтобы обеспечить прочность изделия в течение срока эксплуатации.





EN: GENERAL INSTRUCTION FOR FURNITURE MADE OF WOOD OR WOOD COMPOSITES SUCH AS MELAMINE, LAMINATE OR VENEER SURFACES!

Wipe clean with a damp cloth. Use only water or a gentle detergent.
Wipe dry with a clean cloth.

FR: INSTRUCTIONS GÉNÉRALES POUR LE MOBILIER CONSTITUÉ DE BOIS OU DE COMPOSITES DE BOIS (COMME LES SURFACES EN MELAMINÉ, STRATIFIÉ OU PLACAGE)

Nettoyer à l'aide d'un chiffon humide. Utiliser uniquement de l'eau ou un détergent doux.
Essuyer à l'aide d'un chiffon propre.

LV: VISPĀRĒJI NORĀDĪJUMI MĒBELĒM NO KOKA VAI KOKSNES KOMPOZĪTIEM, PIEMĒRAM, MELAMĪNA, LAMINĀTA VAI FINIERA VIRSMĀM!

Noslaukiet ar mitru drānu. Lietojiet tikai ūdeni vai maigu mazgāšanas līdzekli.
Nosusiniet ar tīru drānu.

LT: BALDŲ IŠ MEDIENOS AR MEDIENOS KOMPOZITO, DENGTO MELAMINU, LAMINATU AR PLONU FANEROS SLUOKSNIU, BENDRIEJI VALYMO NURODYMAI!

Valykite drėgnu skudurėliu. Naudokite tik vandenį arba švelnų valiklį.
Nausausinkite švariu skudurėliu.

EE: PUIDUST VÕI MITMEKIHILISEST PUIDUST, NAGU MELAMIINIST, LAMINAADIST VÕI VINEERIST MÖÖBLI ÜLDJUHISED!

Kasutage puhastamiseks niisket lappi. Kasutage ainult vett või õrnatoimelist puhastusvahendit.
Pühkige puhta lapiga kuivaks.

RU: ОБЩИЕ УКАЗАНИЯ ОТНОСИТЕЛЬНО МЕБЕЛИ, ИЗГОТОВЛЕННОЙ ИЗ ДЕРЕВА ИЛИ ДРЕВЕСНЫХ КОМПОЗИЦИОННЫХ МАТЕРИАЛОВ, ТАКИХ КАК МЕЛАМИН, ЛАМИНАТ ИЛИ ШПОН!

Очистите изделие чистой влажной тканью. Используйте мягкодействующее моющее средство.
Вытрите досуха чистой тряпкой.

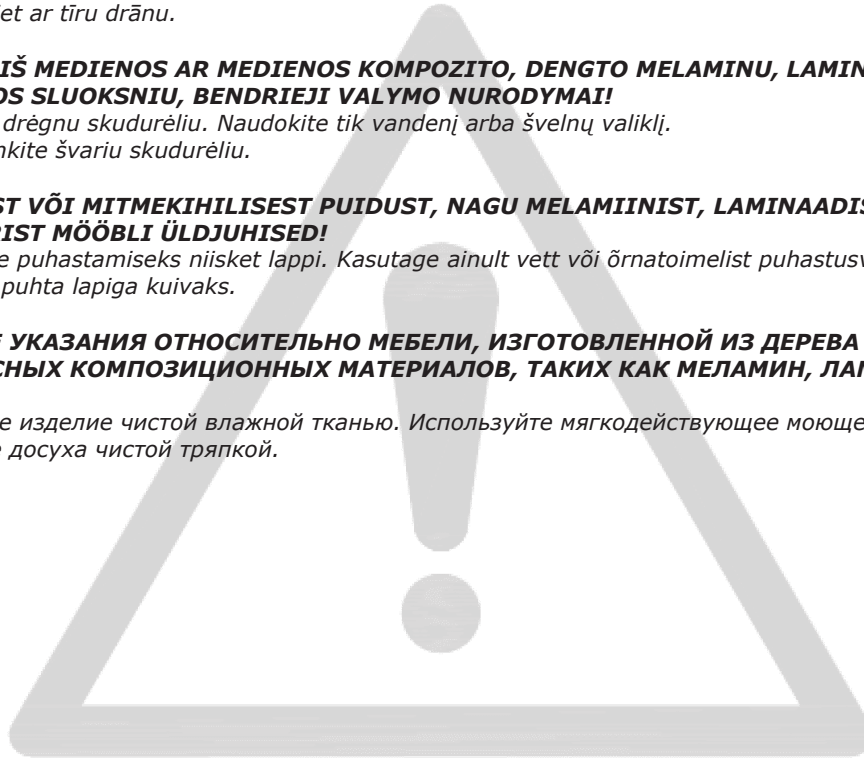



EN: GENERAL INSTRUCTION FOR FURNITURE WITH FABRIC!

Wipe clean with a damp cloth. Use only clean water.

Dust and dirt can be vacuum cleaned or wiped with a clean soft cloth.

Do not use detergents, solvents or other chemicals on fabric as this may cause discoloration.

However, certain removable fabrics may be washed, but in such cases there will ALWAYS be a washing instruction on the fabric.

FR: INSTRUCTIONS GÉNÉRALES POUR LE MOBILIER EN TISSU!

Nettoyez à l'aide d'un chiffon humide. N'utilisez que de l'eau claire.

La poussière et la saleté peuvent être aspirées ou essuyées à l'aide d'un chiffon doux et propre.

N'utilisez aucun détergent, solvant ou autre produit chimique sur le tissu, car ceci pourrait le décolorer.

Cependant, certains tissus amovibles peuvent être lavés, mais dans ce cas le tissu comportera TOUJOURS des instructions de lavage.

LV: VISPĀRĪGI KOPŠANAS NORĀDĪJUMI MĒBELĒM AR AUDUMU!

Noslaukiet ar mitru drānu. Izmantojiet tikai tīru ūdeni.

Puteklus un netīrumus var notīrīt ar puteklusūcēju vai noslaucīt ar mīkstu drānu.

Auduma tīrīšanai neizmantojiet mazgāšanas līdzekļus, šķīdinātājus vai citas ķīmikālijas, jo auduma krāsa var izbalēt.

Atsevišķus noņemamos audumus var mazgāt, taču tad uz auduma VIENMĒR būs sniegti kopšanas norādījumi.

LT: BENDROSIOS INSTRUKCIJOS BALDAMS PADENGTIEMS AUDINIUI!

Švariai nušluostykite drėgna šluoste. Naudokite tik švarų vandenį.

Dulkės ir nešvarumai gali būti susiurbti arba nuvalyti švaria, minkšta šluoste.

Nenaudokite detergentų, tirpiklių ar kitų chemikalų audiniams, nes šie gali sukelti spalvos išblukimą.

Visgi, kai kurie nuimami audiniai gali būti skalbiami, bet tokiais atvejais ant audinio etiketės VISADA turi būti pateiktos skalbimo instrukcijos.

EE: ÜLDISED JUHISED KANGAGA MÖÖBLI JAOKS!

Puhastage niiske lapiga. Kasutage ainult puhast vett.

Tolmu ja mustust saab eemaldada tolmuimejaga või ära pühkida puhta pehme lapiga.

Ärge kasutage kangal pesuvahendeid, lahusteid või muid kemikaale, kuna see võib põhjustada värvimuutusi.

Küll aga võib teatud eemaldatavaid kangaid pesta, kuid sellisel juhul on kanga küljes ALATI pesujuhend.

RU: ОБЩИЕ УКАЗАНИЯ ПО УХОДУ ЗА МЕБЕЛЬЮ С ОТДЕЛКОЙ ИЗ ТКАНИ!









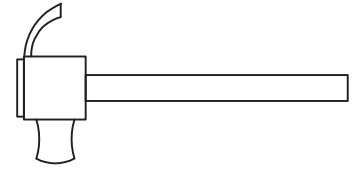
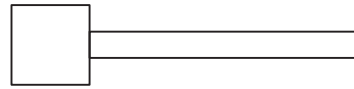
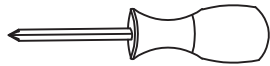
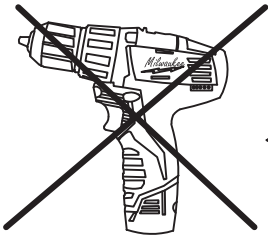









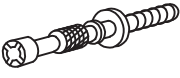
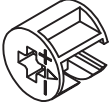

Очистите изделие чистой влажной тряпкой. Используйте только чистую воду.

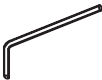
Пыль и грязь можно удалять пылесосом или чистой мягкой тряпкой.

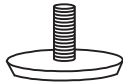
Не наносите моющие средства, растворители или другие химические вещества на ткань, поскольку они могут привести к вымыванию цвета.

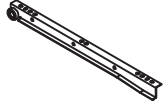
Некоторые съемные элементы из ткани можно стирать. В таких случаях к ткани ОБЯЗАТЕЛЬНО прилагается инструкция по стирке.



<p>A x31</p>  <p>(8 x 25mm)</p>	<p>B x17</p>  <p>JCBC W M6 x 40mm</p>	<p>C x10</p>  <p>JCBC M6 x 40mm</p>	<p>D x4</p>  <p>JCBC M6 x 60mm</p>
<p>E x48</p>  <p>M3.5 x 16mm</p>	<p>F x2</p>  <p>M4 x 25mm</p>	<p>G x18</p>  <p>M4 x 32mm</p>	<p>H x32</p>  <p>M4 x 50mm</p>
<p>I x10</p>  <p>∅ 4 x 32mm</p>	<p>J x10</p>  <p>∅ 12 x 10mm</p>	<p>K x10</p>  <p>∅ 15mm</p>	<p>L x52</p>  <p>3/8</p>
<p>M x16</p>  <p>13 x 5mm</p>	<p>N x1</p>  <p>M4 x 65mm</p>	<p>O x14</p>  <p>20 x 1mm</p>	<p>P x4</p>  <p>35mm x 30mm x 5mm</p>
<p>Q x8</p>  <p>JCBC M6 x 30mm</p>	<p>R x8</p>  <p>500mm (20")</p>	<p>S x8</p>  <p>500mm (20")</p>	<p>T x4</p>  <p>M6 x 12.5</p>
<p>U x4</p>  <p>JCBC M6 x 50mm</p>			

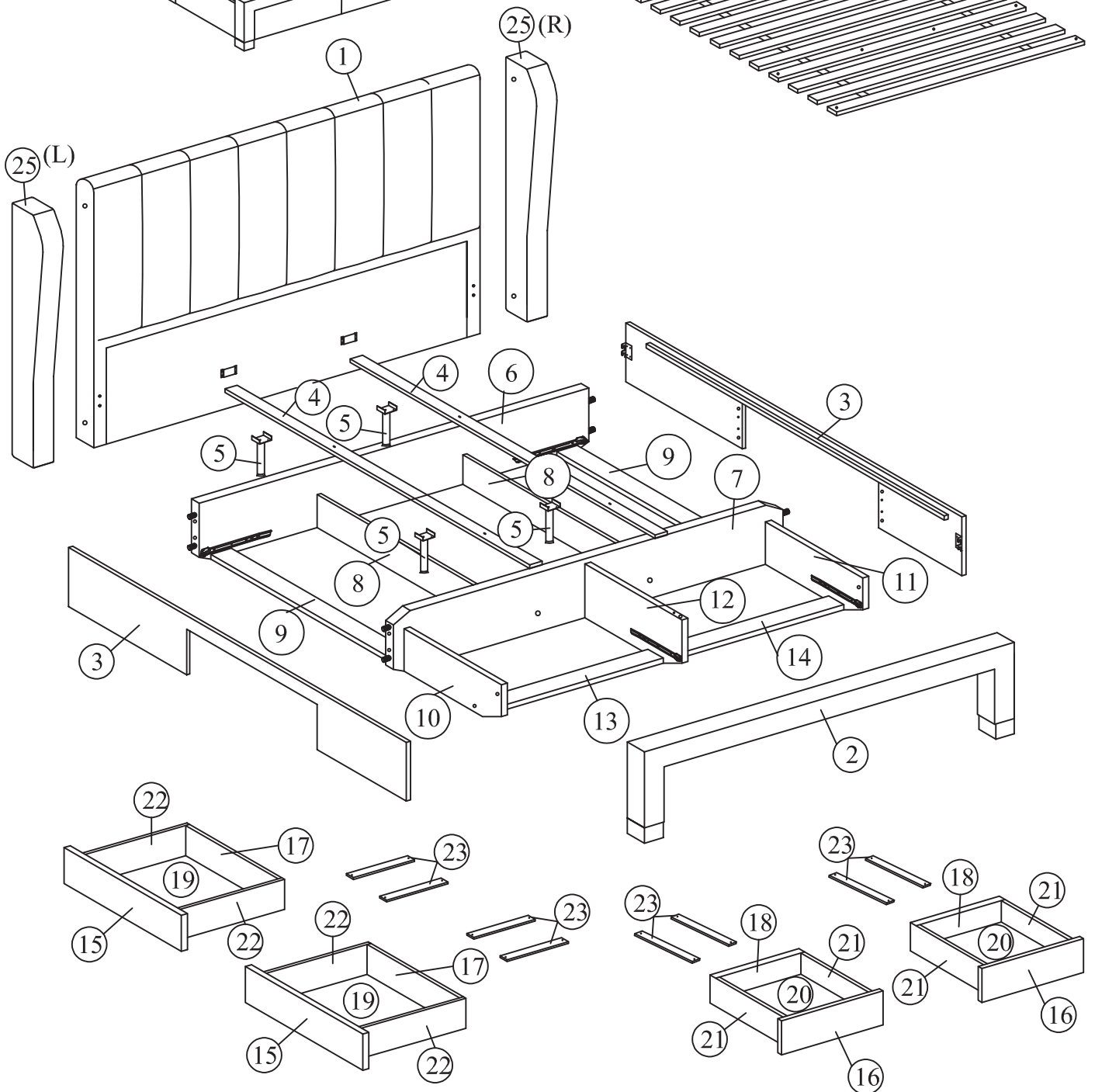
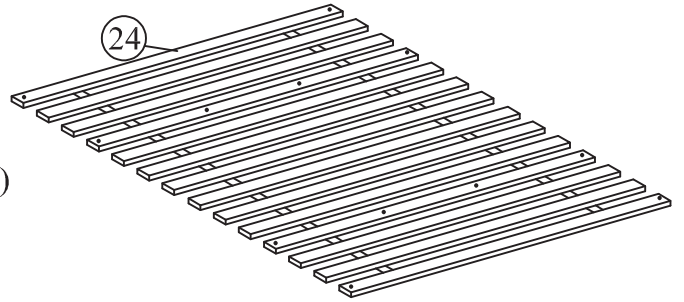
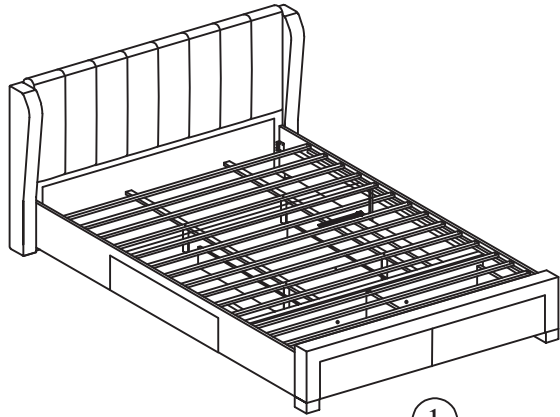

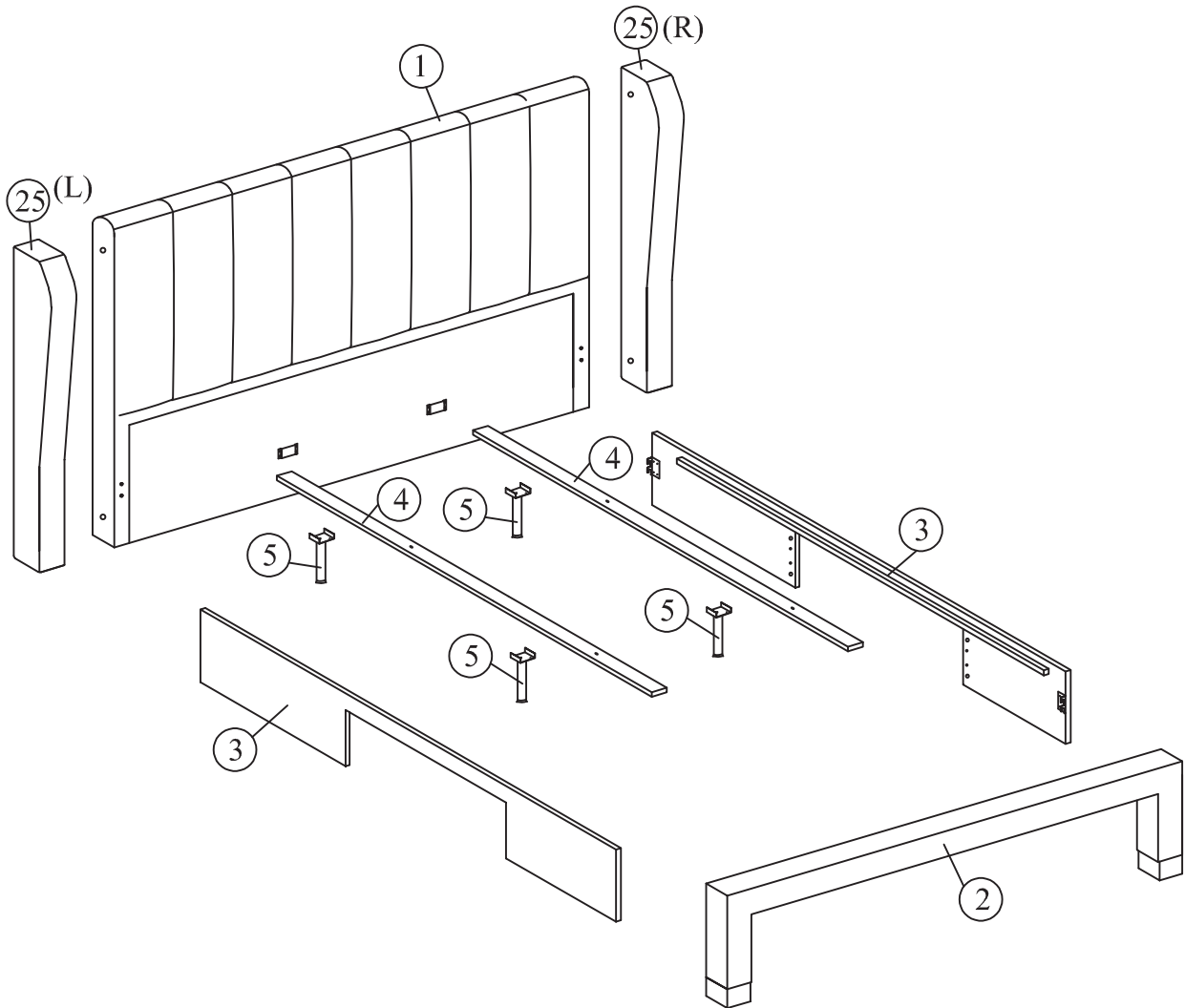
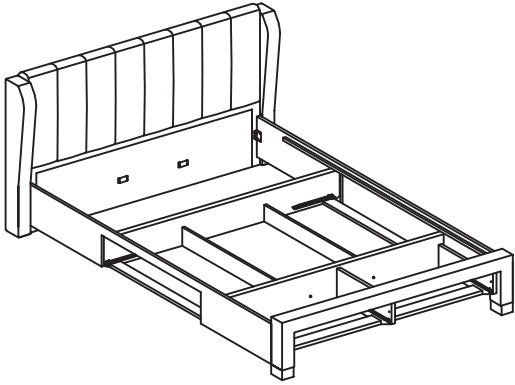

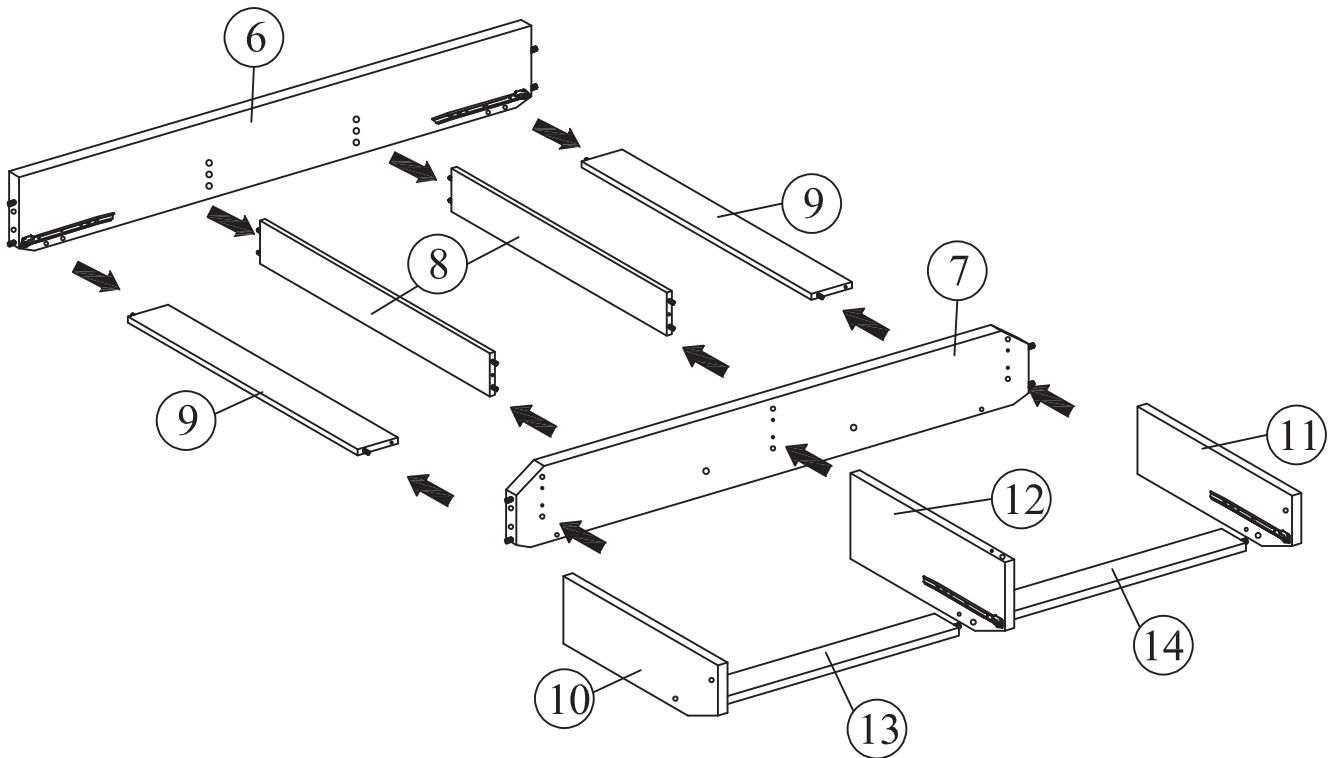
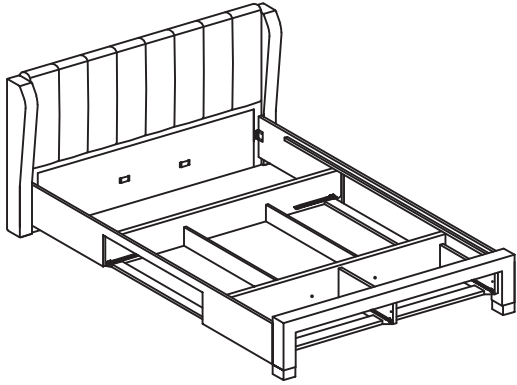

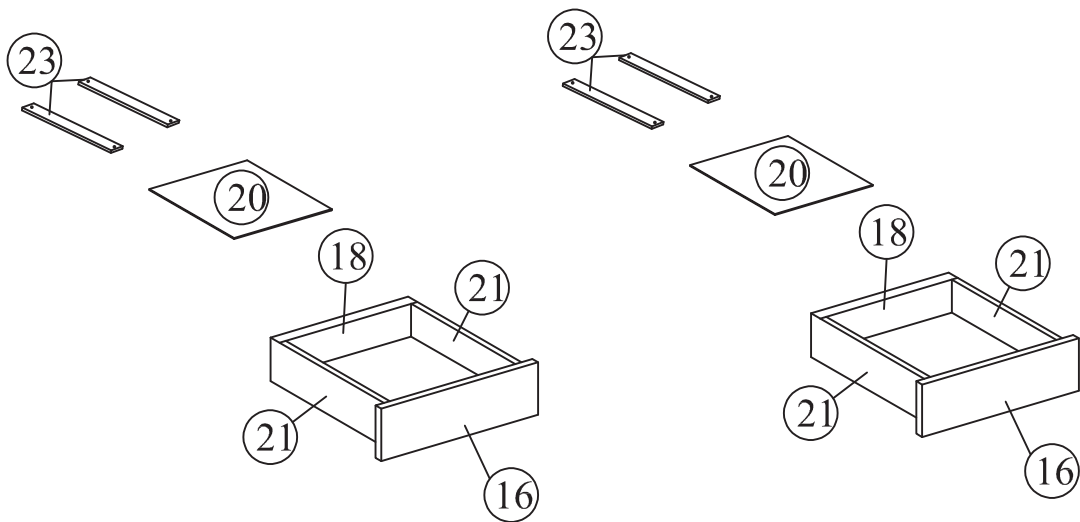
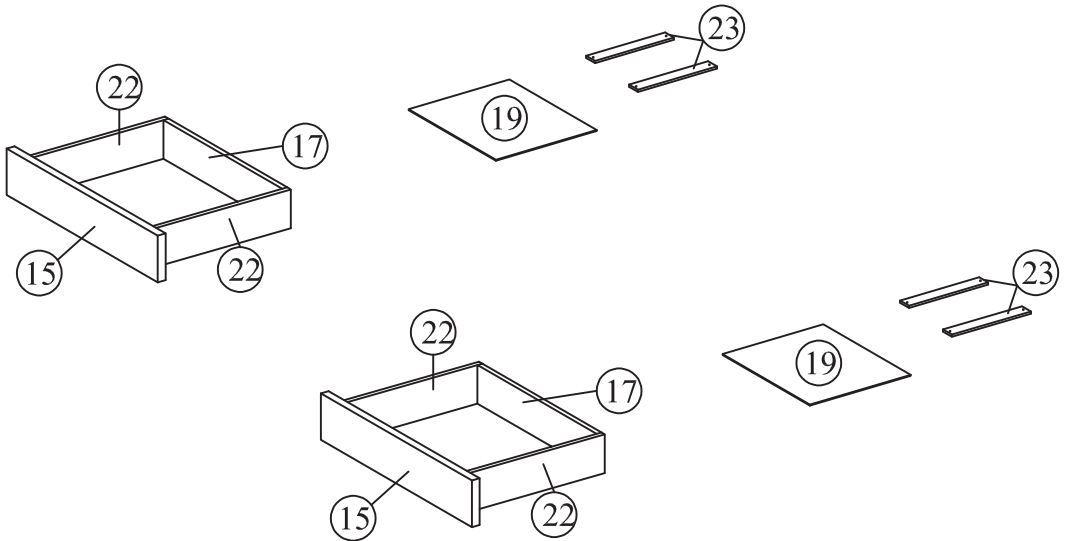
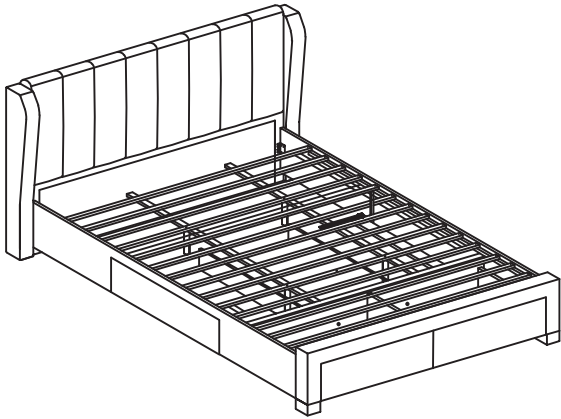

Box 1 / 6

500 x 180 x 15 mm

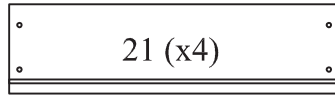

500 x 140 x 15 mm

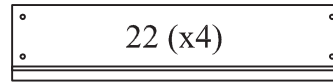

746 x 157 x 15 mm

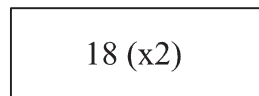

756 x 117 x 15 mm

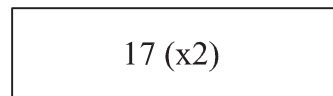

765 x 500 x 2.5 mm

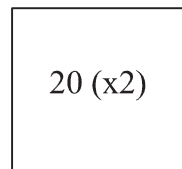

766 x 500 x 2.5 mm

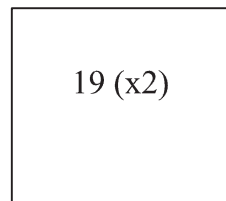

500 x 45 x 15 mm



23 (x8)

250mm

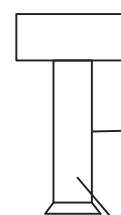

5 (x4)

Ø 23mm

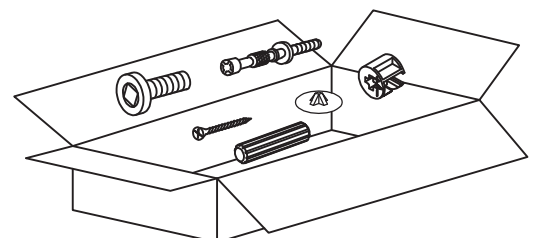

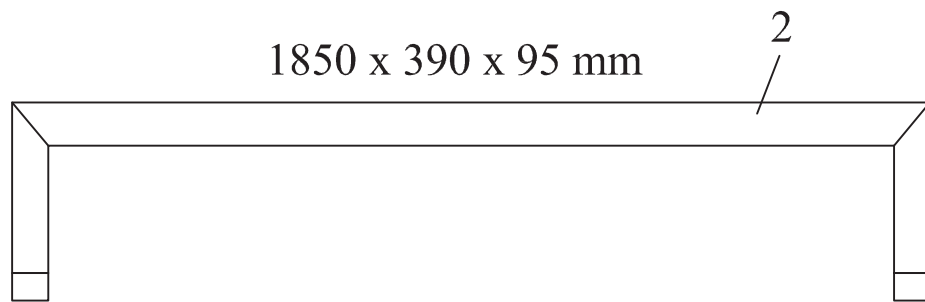

811 x 230 x 15 mm

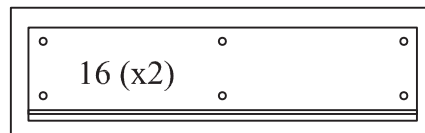

Box 3 / 6

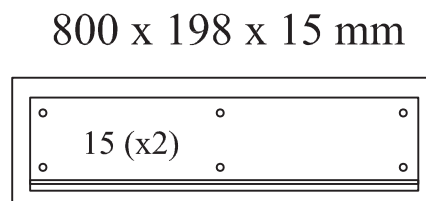
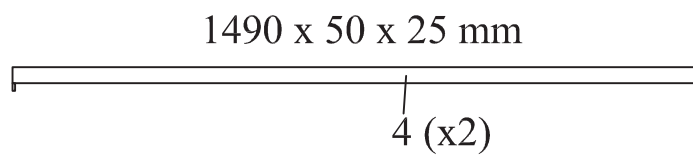
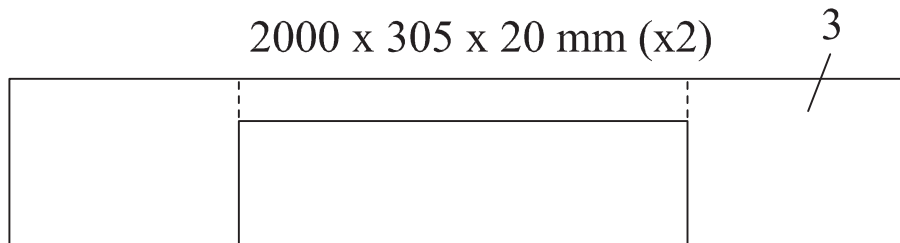

1850 x 1242 x 110 mm

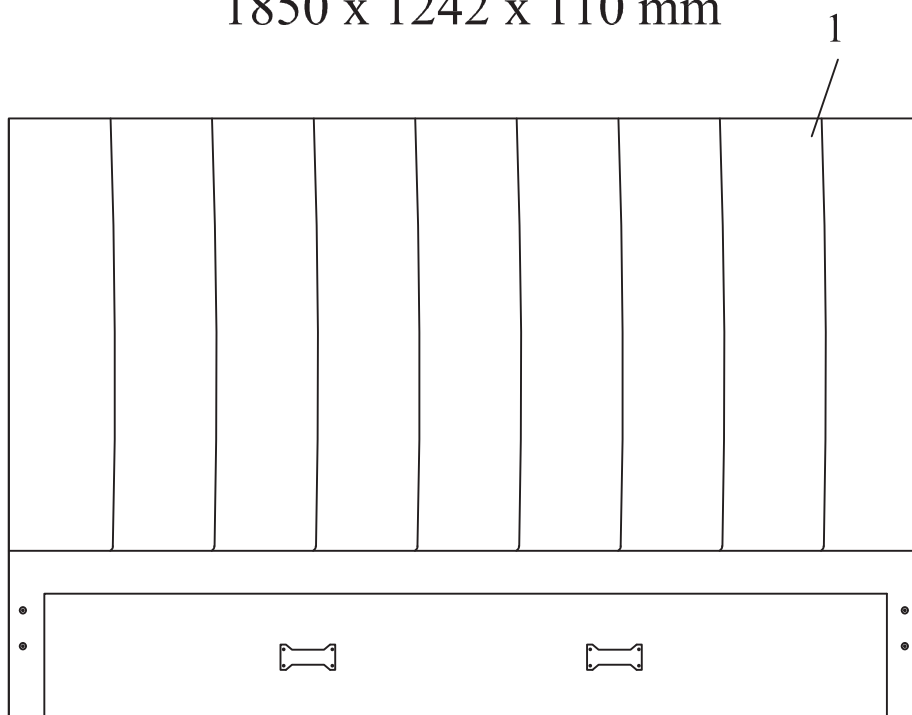

1215 x 190 x 45 mm

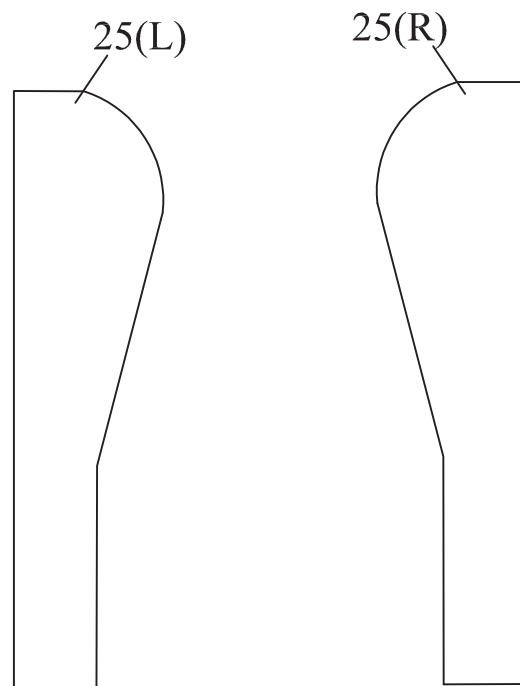

Box 5 / 6

1800 x 238 x 15 mm

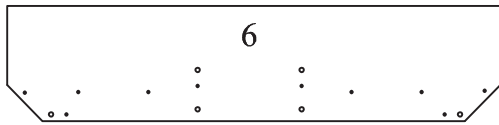

1800 x 283 x 15 mm

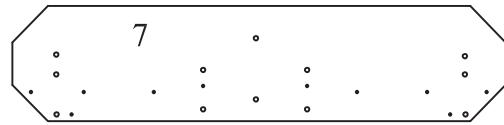

813 x 140 x 15 mm

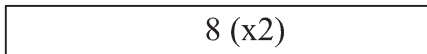

813 x 76 x 15 mm

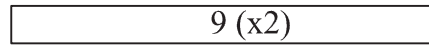

550 x 191 x 15 mm

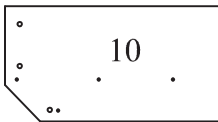

550 x 191 x 15 mm

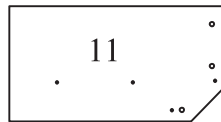

550 x 281 x 15 mm

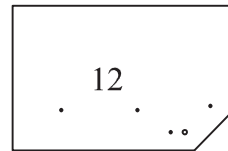

802 x 76 x 15 mm

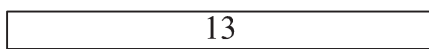

802 x 76 x 15 mm

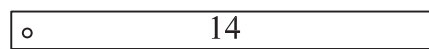

1797 x 45 x 18 mm

24

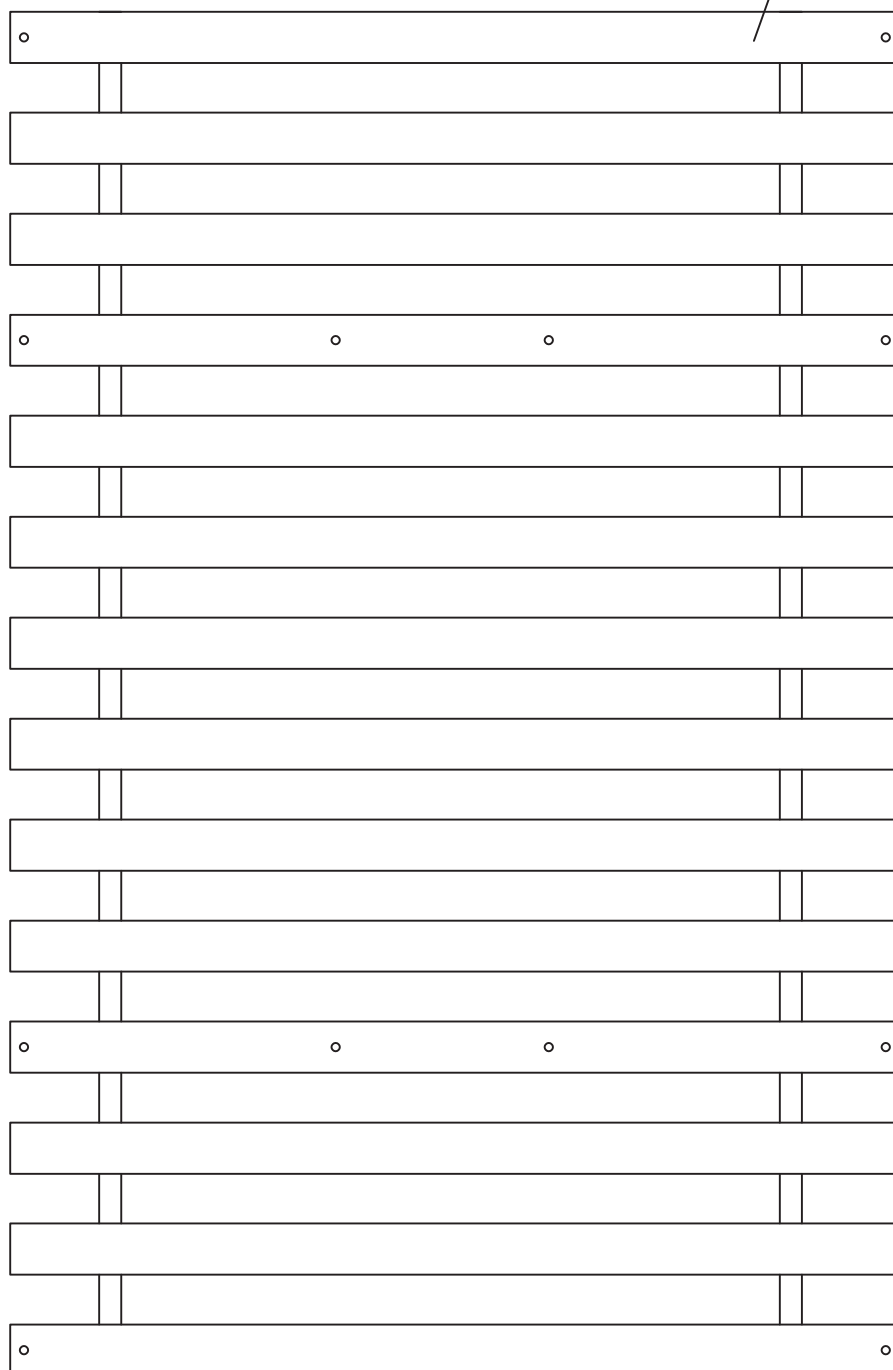

1

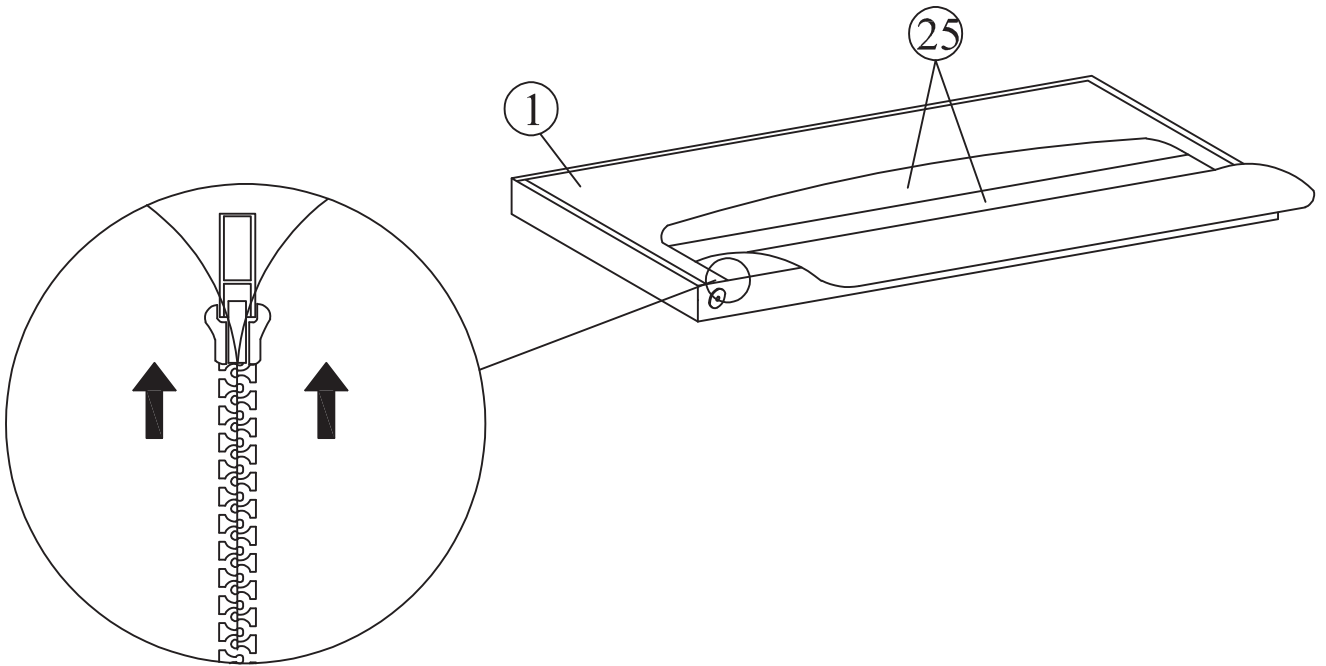

2

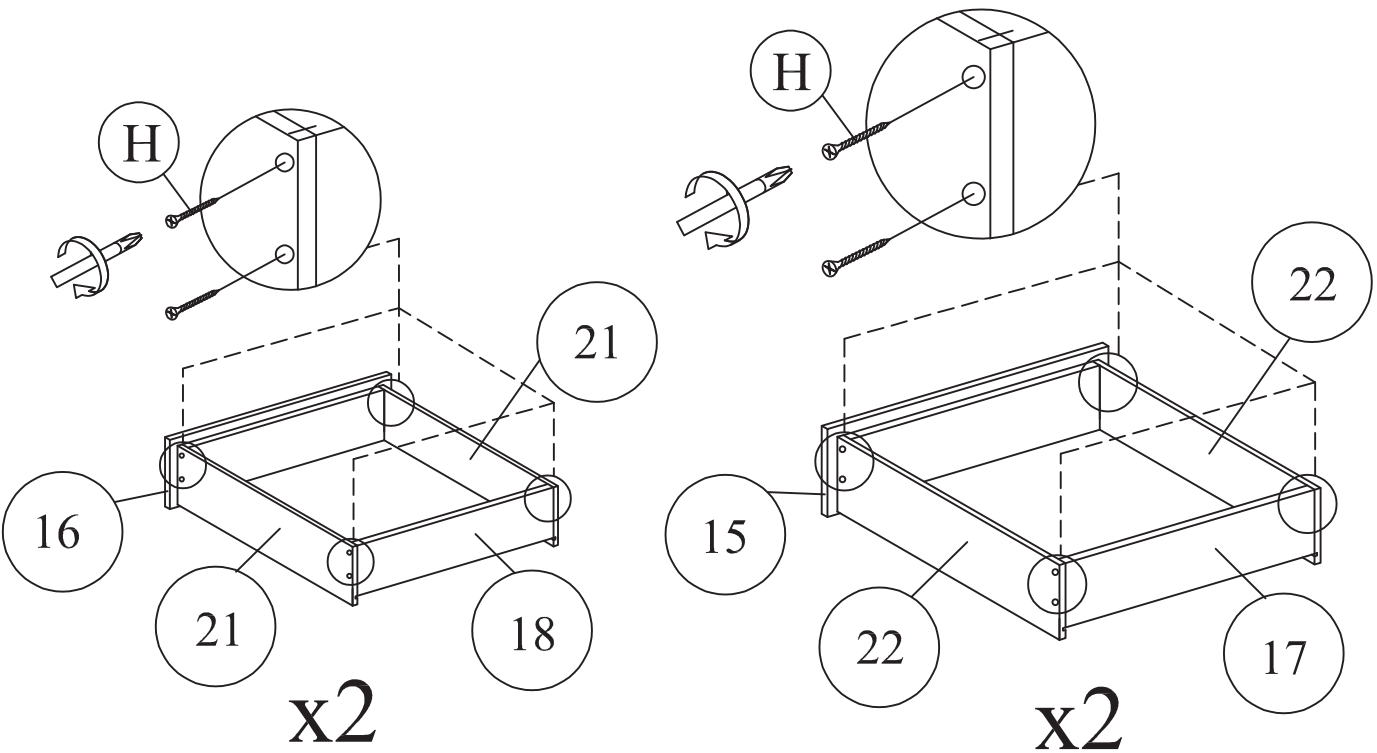
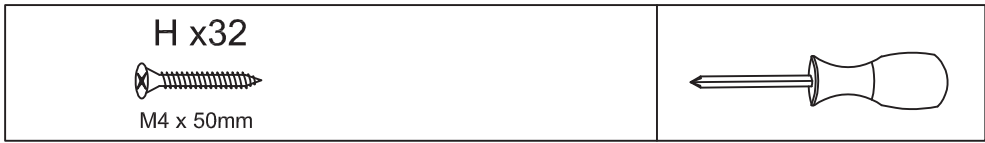

3

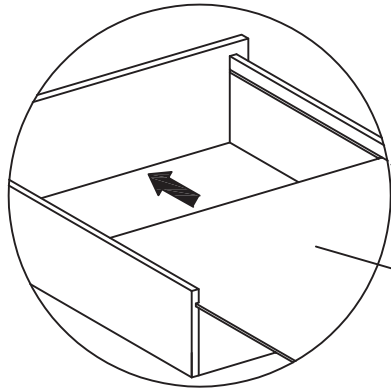

19, 20

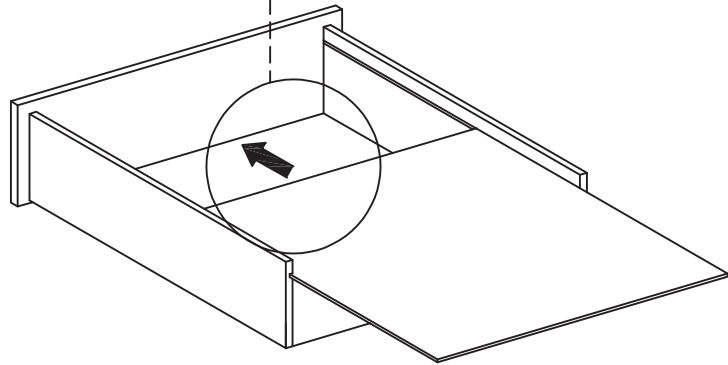

x2

4

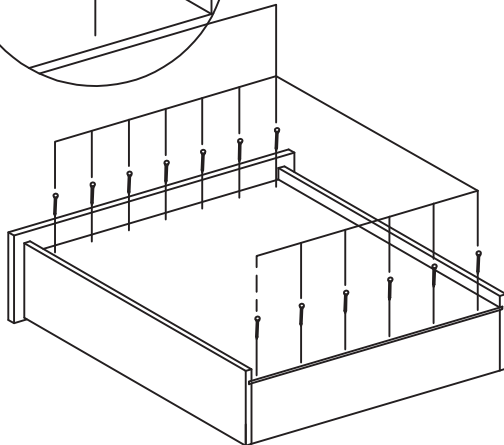
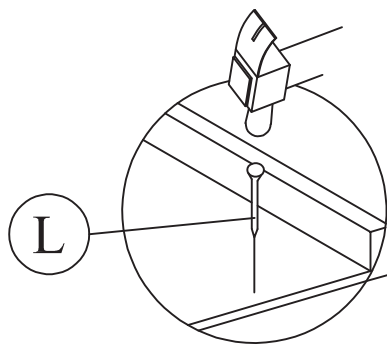

x4

5

<p>G x16 M4 x 32mm</p> 	
--	---

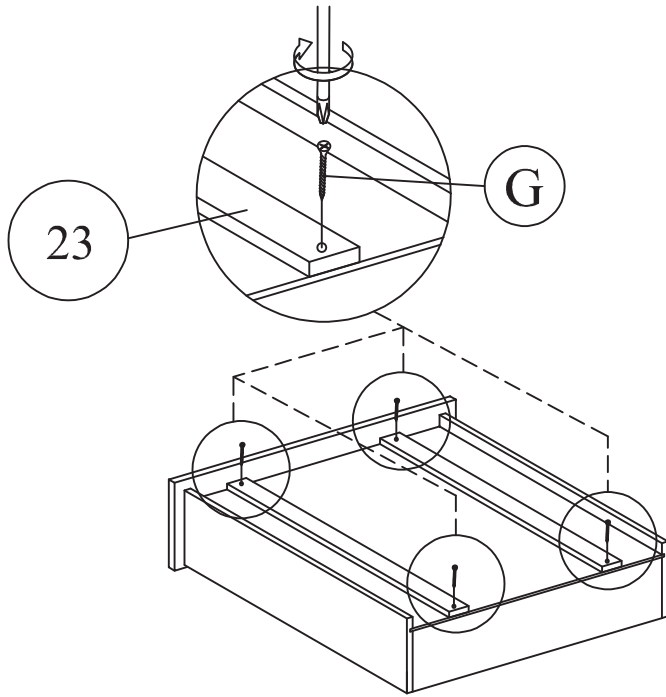

x4

6

<p>E x24 M3.5 x 16mm</p> 	<p>R x8 500mm (20")</p> 	
--	---	---

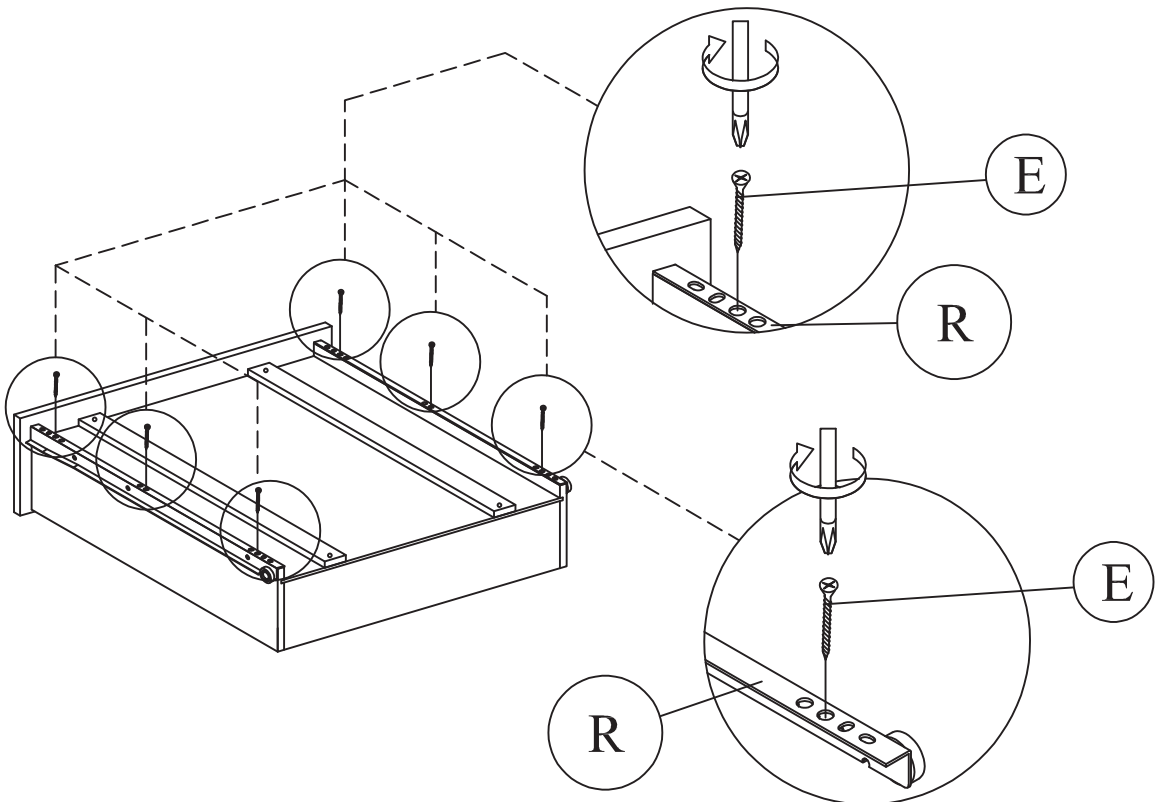

x4

7

E x6  M3.5 x 16mm	S x2  500mm (20")	
---	---	---

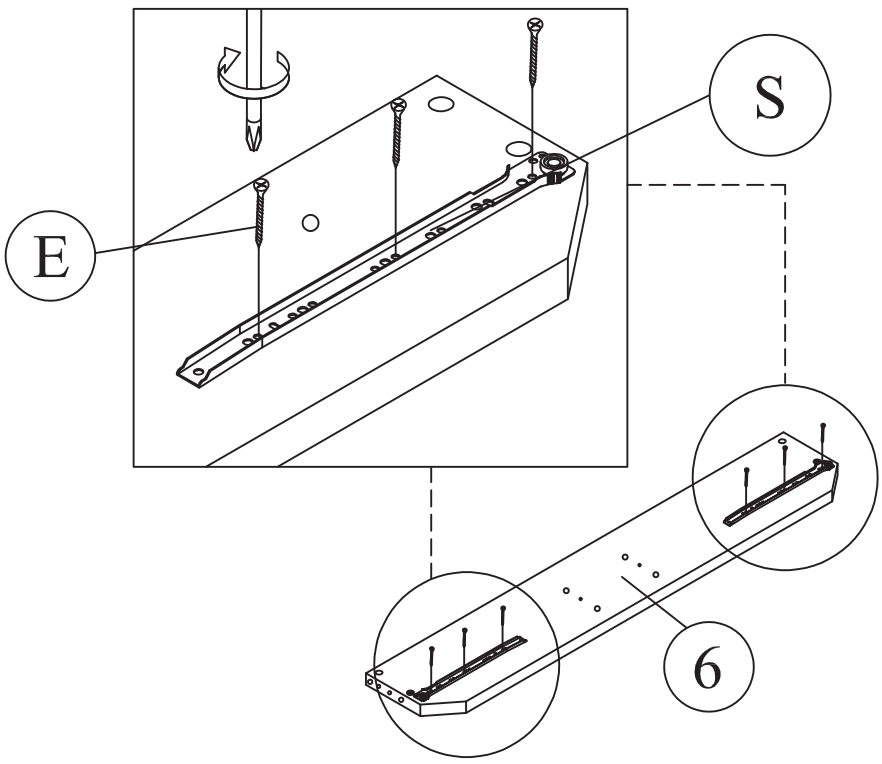

8

A x4  8x25mm	M x3  13x5mm	
--	--	---

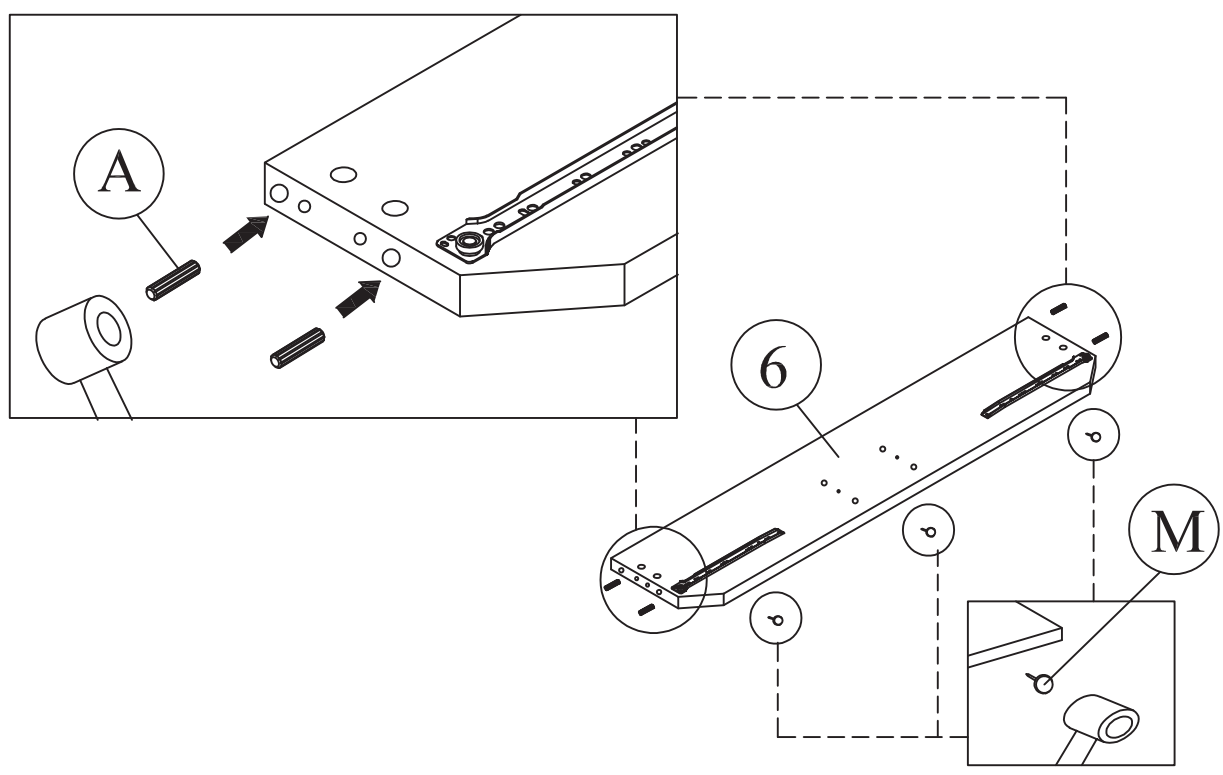

9

E x6  M3.5 x 16mm	S x2  500mm (20")	
---	---	---

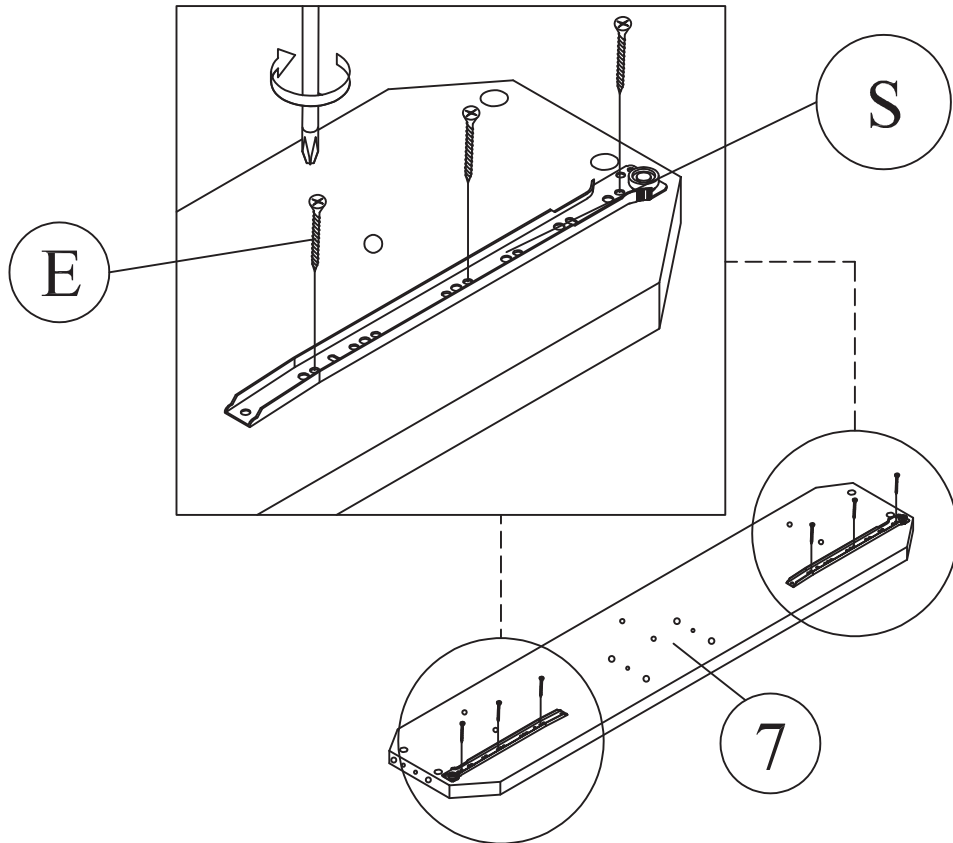

10

A x4  8x25mm	M x3  13x5mm	
--	--	---

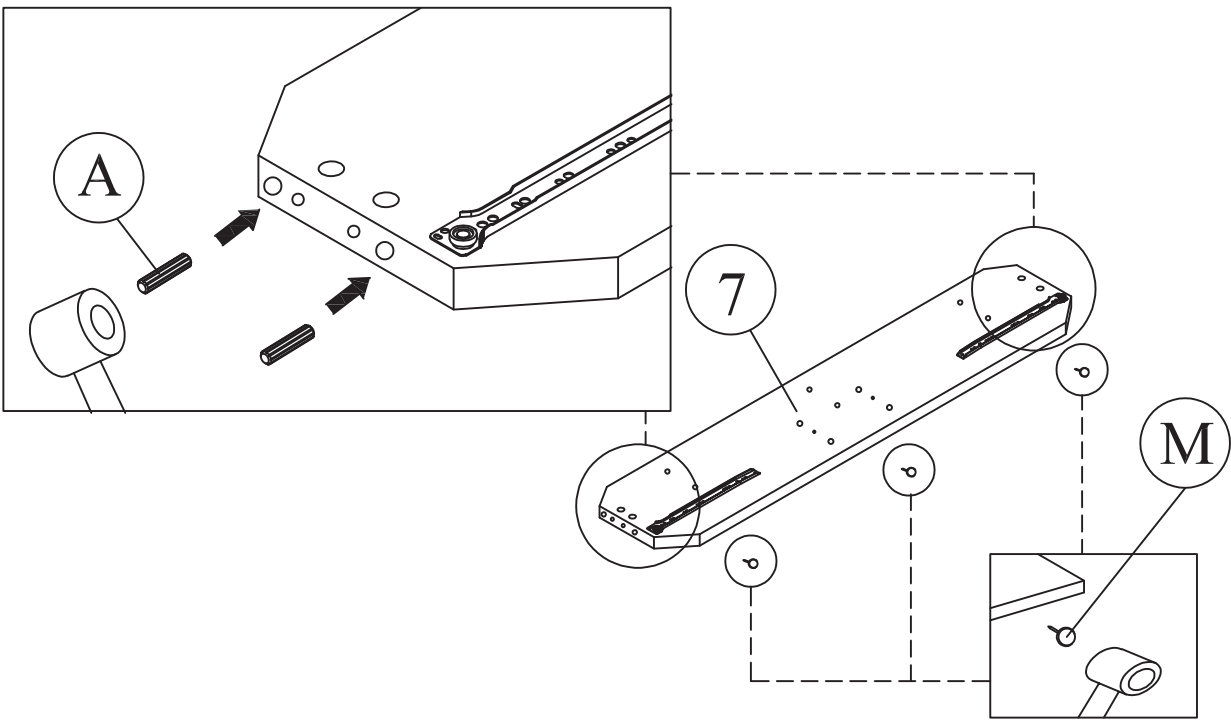

11

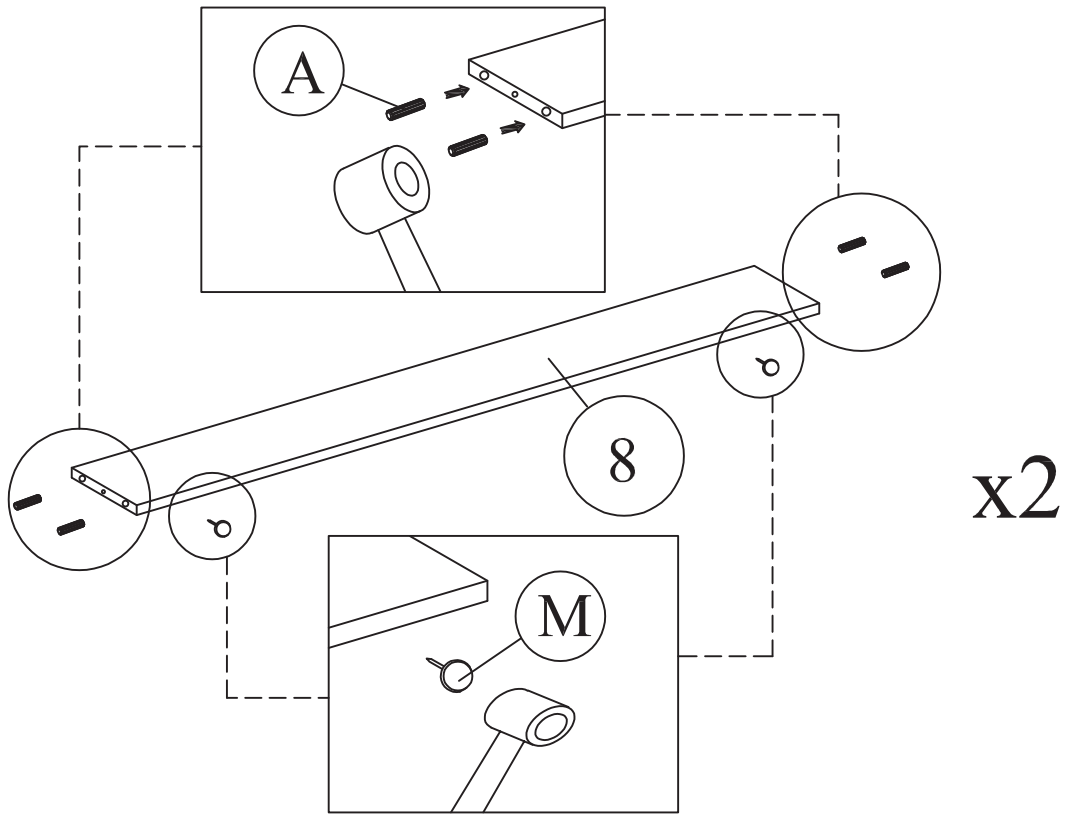

12

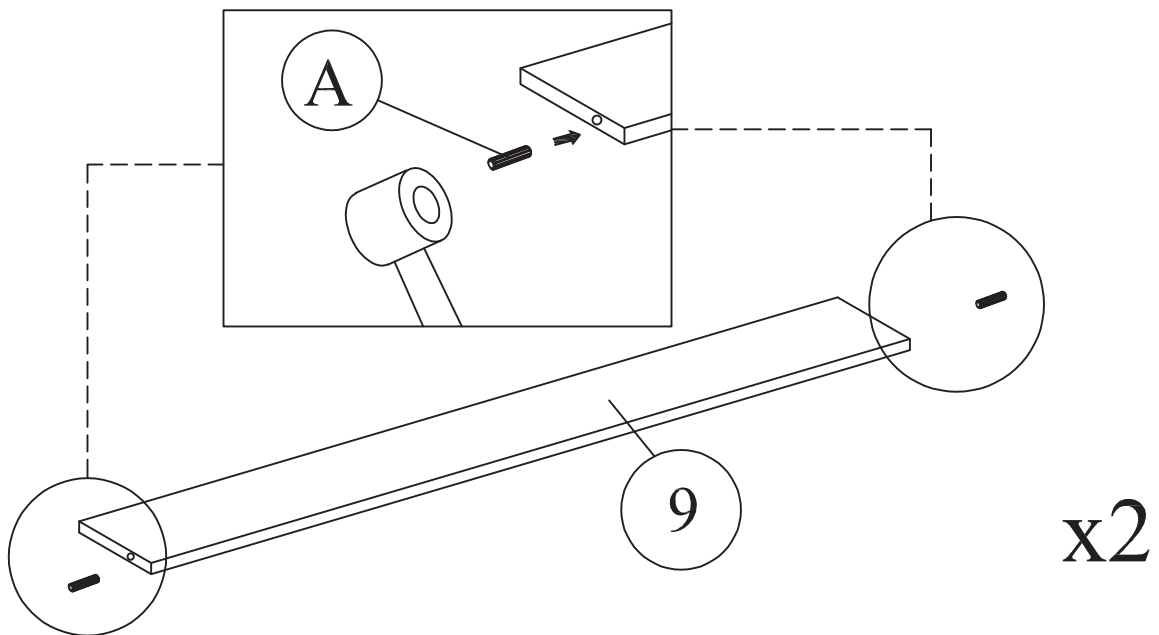



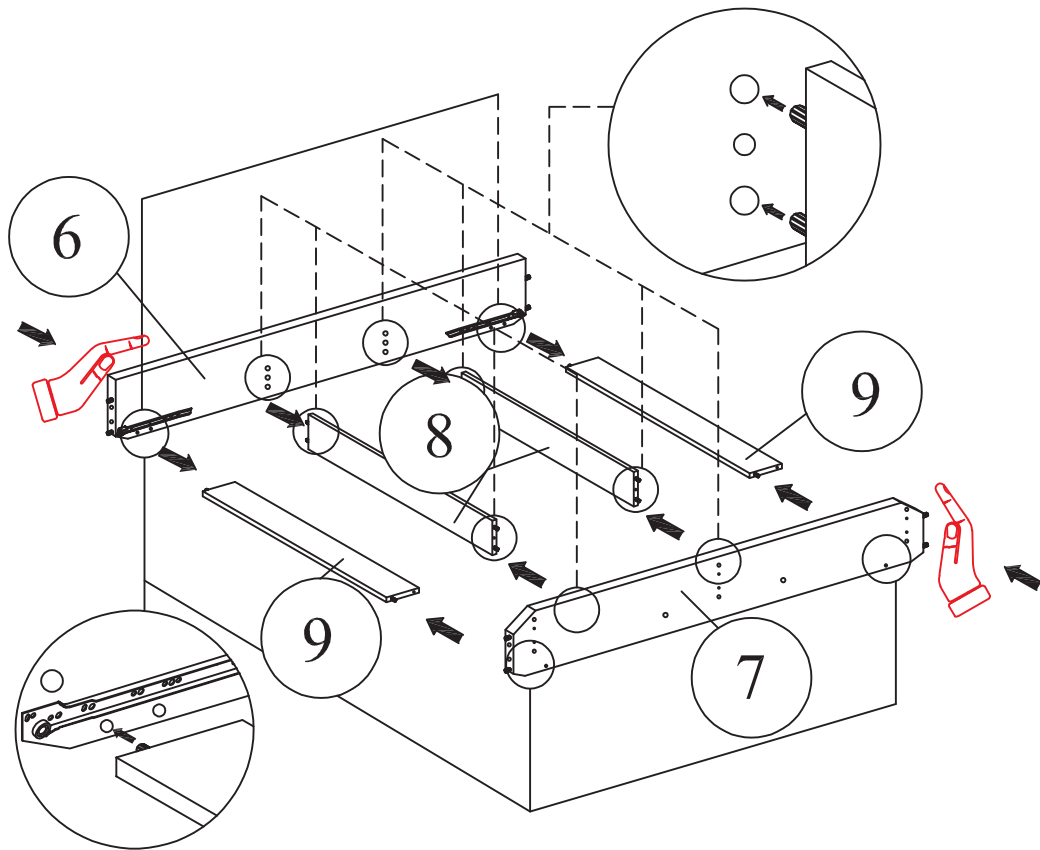

13

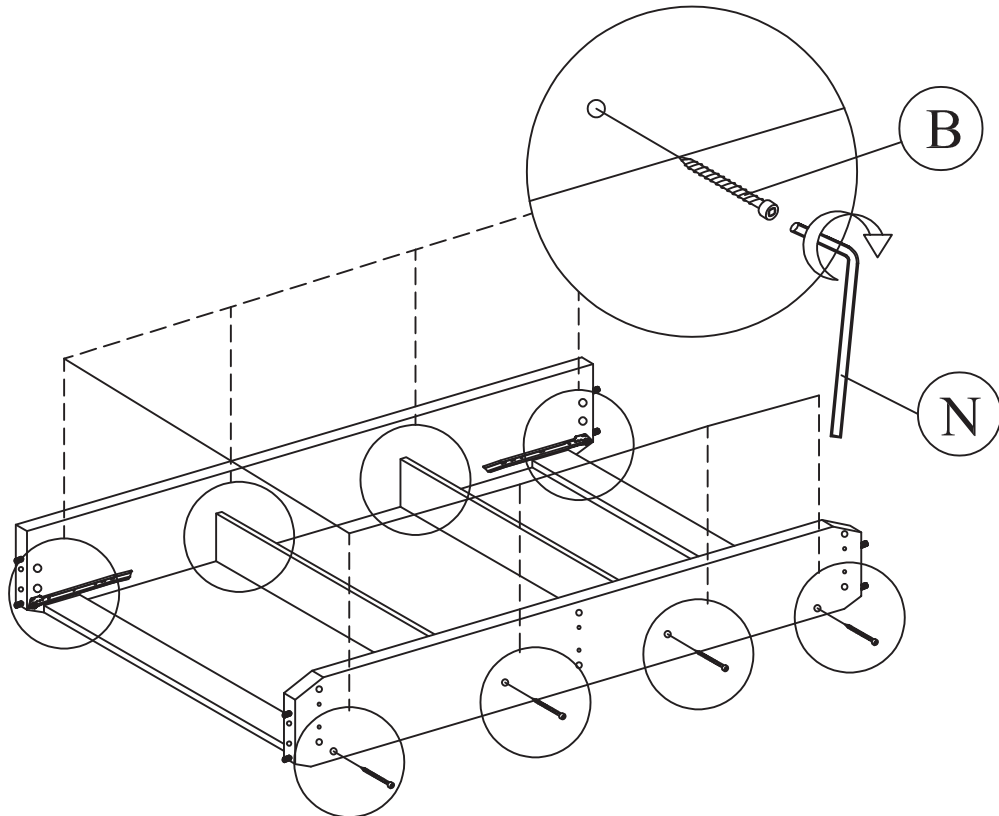

14

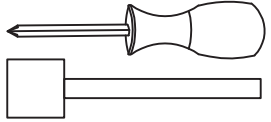

15

A x2  8x25mm	E x3  M3.5 x 16mm	M x2  13x5mm	S x1  500mm (20")	
--	---	--	---	---

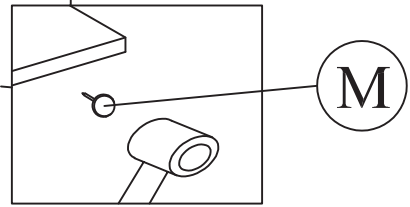
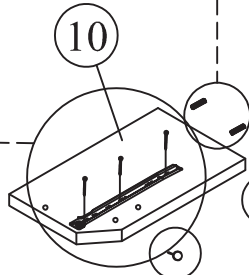
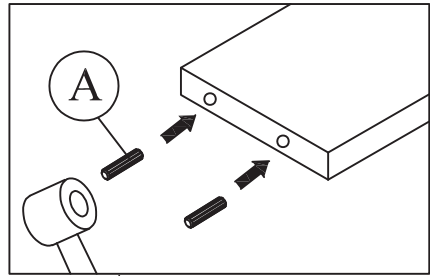
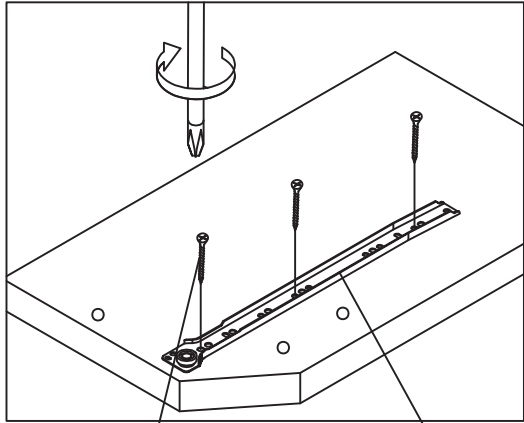





E

S

10

M

16

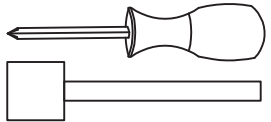
A x2  8x25mm	E x3  M3.5 x 16mm	M x2  13x5mm	S x1  500mm (20")	
--	---	--	---	---

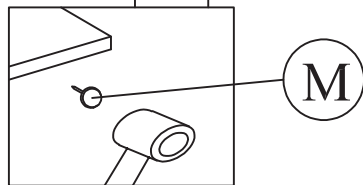
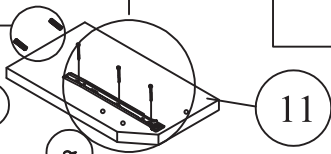
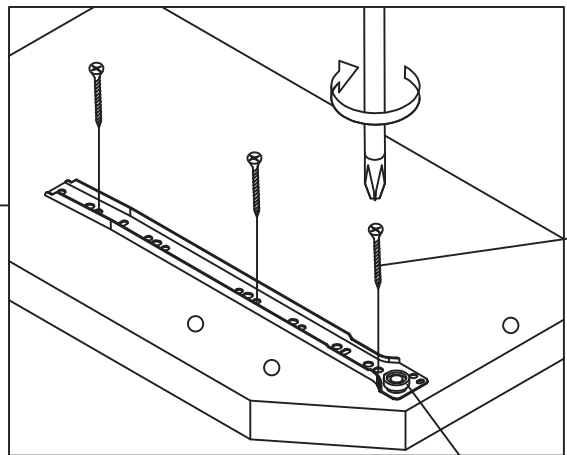
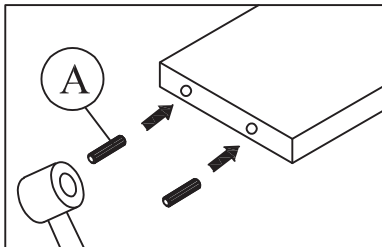





E

S

11

M

17

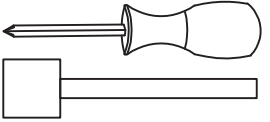
A x2  8x25mm	E x6  M3.5 x 16mm	M x2  13x5mm	S x2  500mm (20")	
--	---	--	---	---

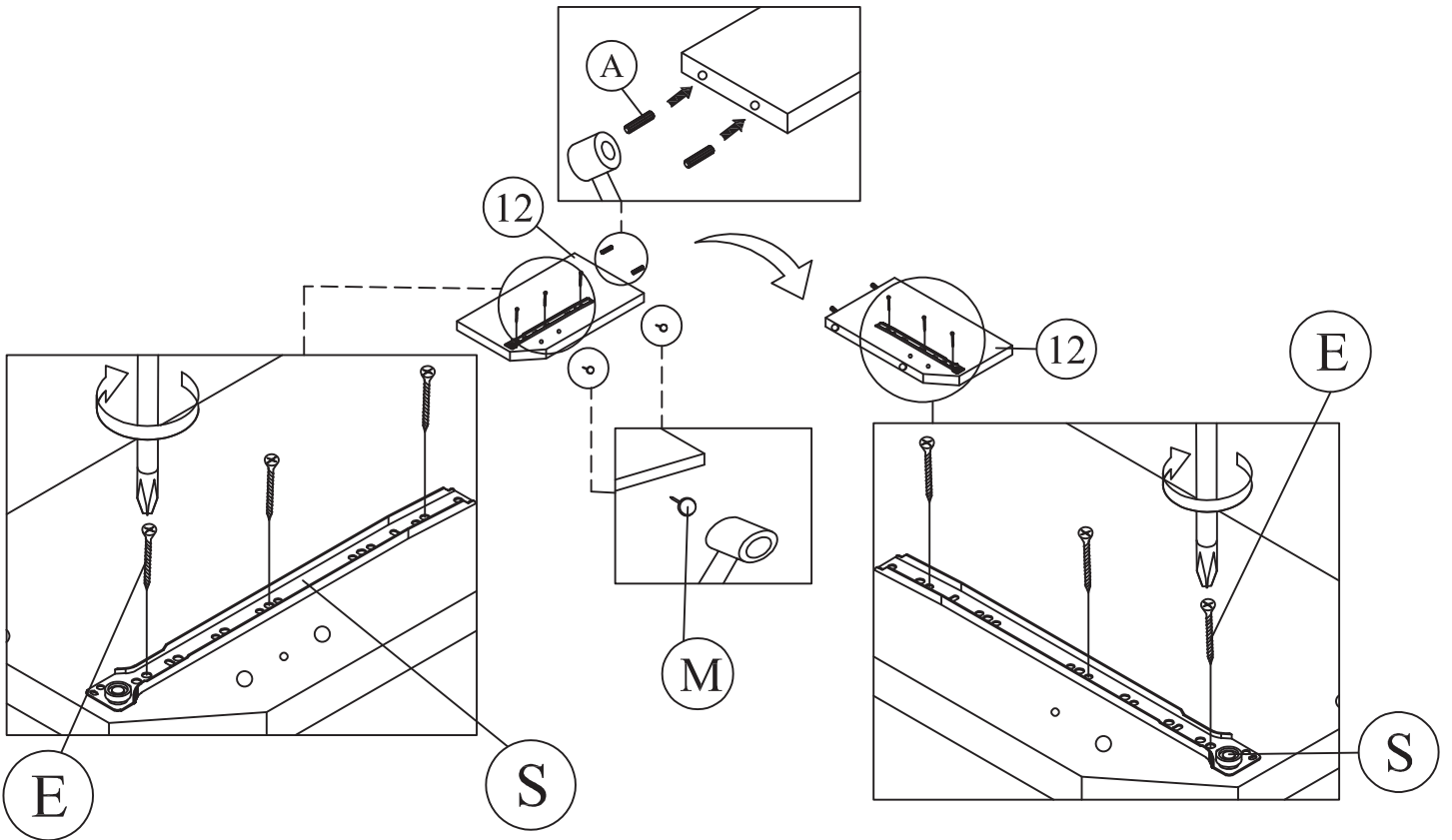

18

A x2  8x25mm	
--	---

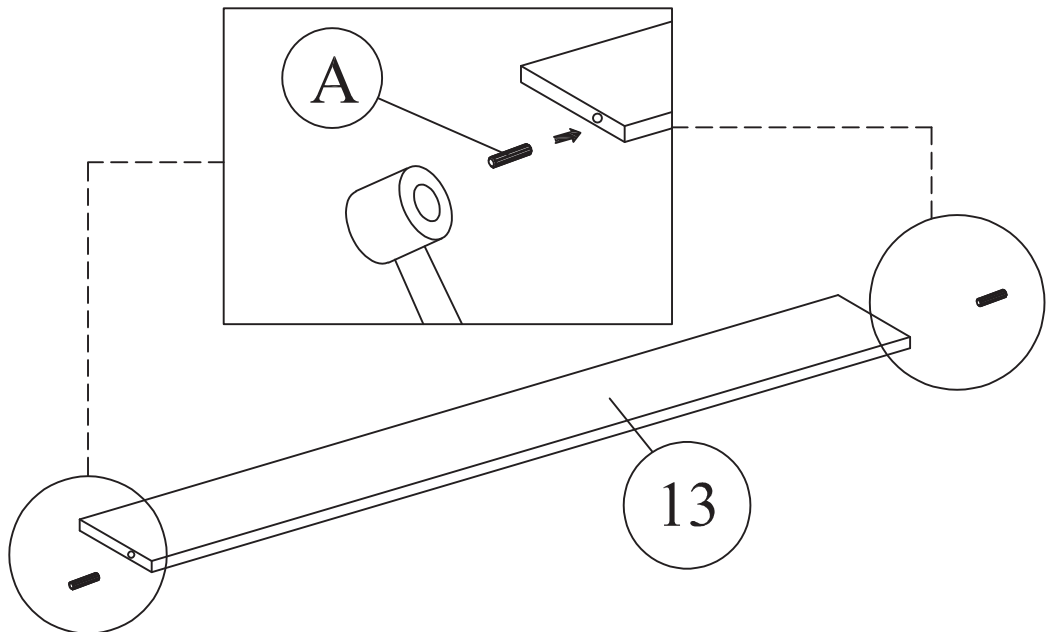

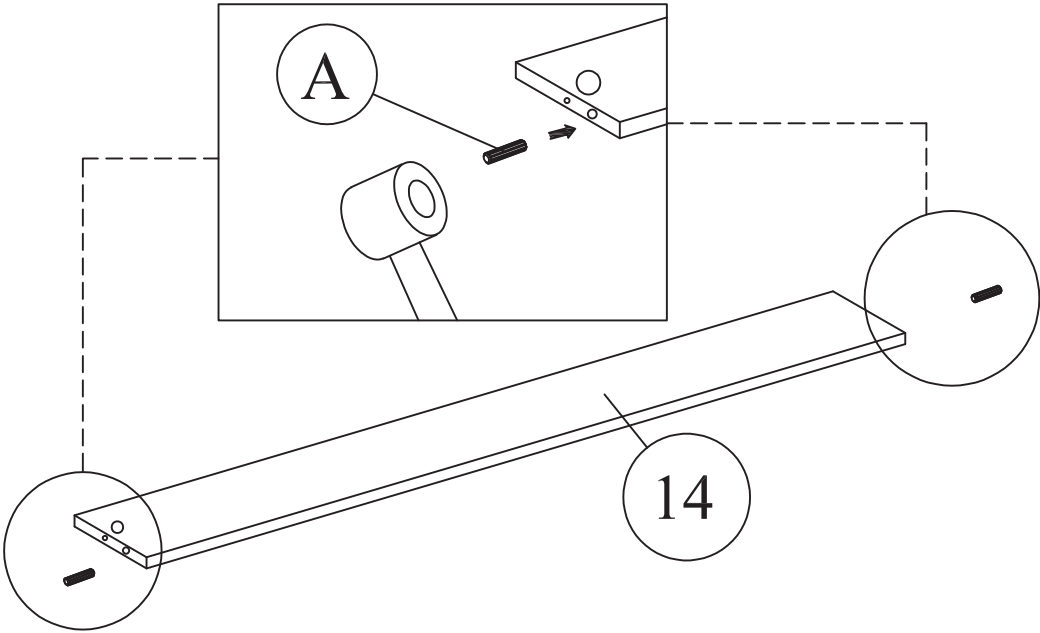

19

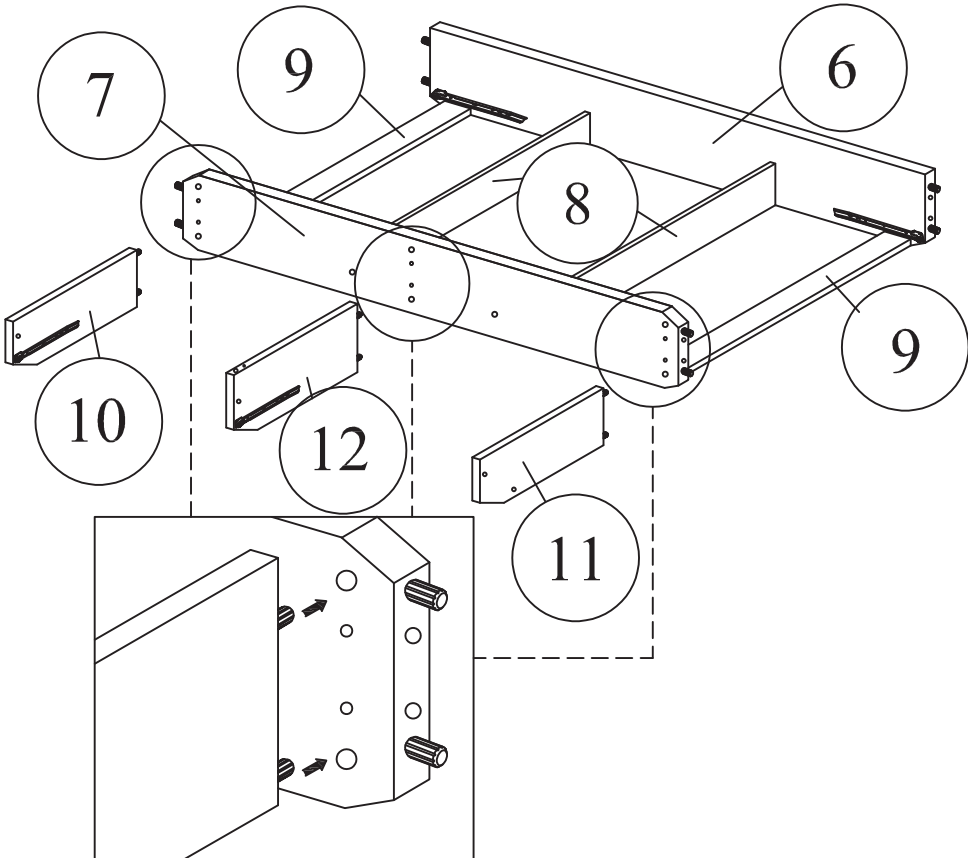
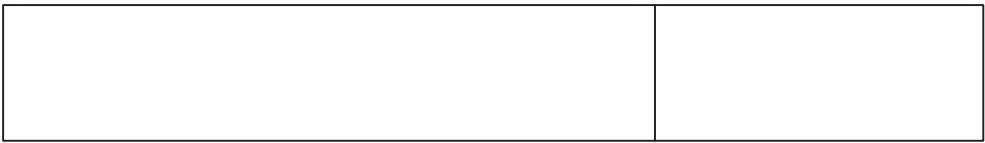

20



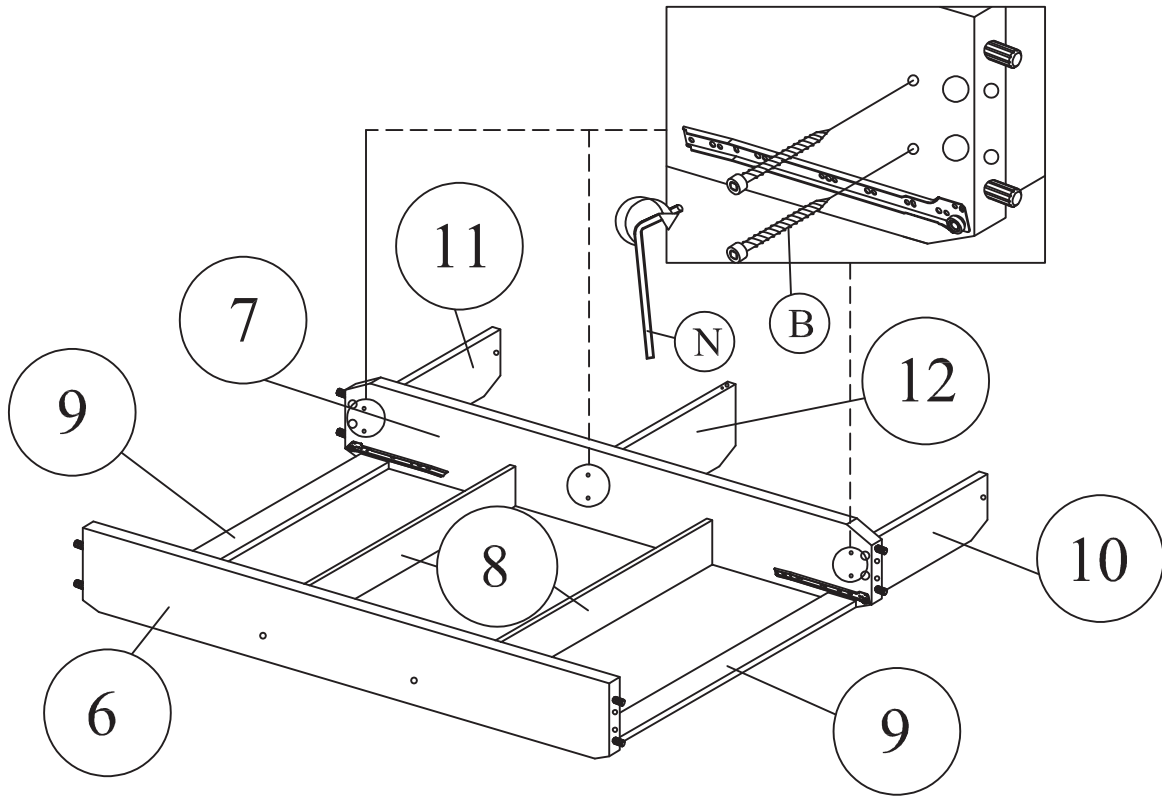

21

B x6 JCBC W M6 x 40mm 	N x1 M4 x 65mm 	
--	---	--



22

B x2 JCBC W M6 x 40mm 	N x1 M4 x 65mm 	
--	---	--

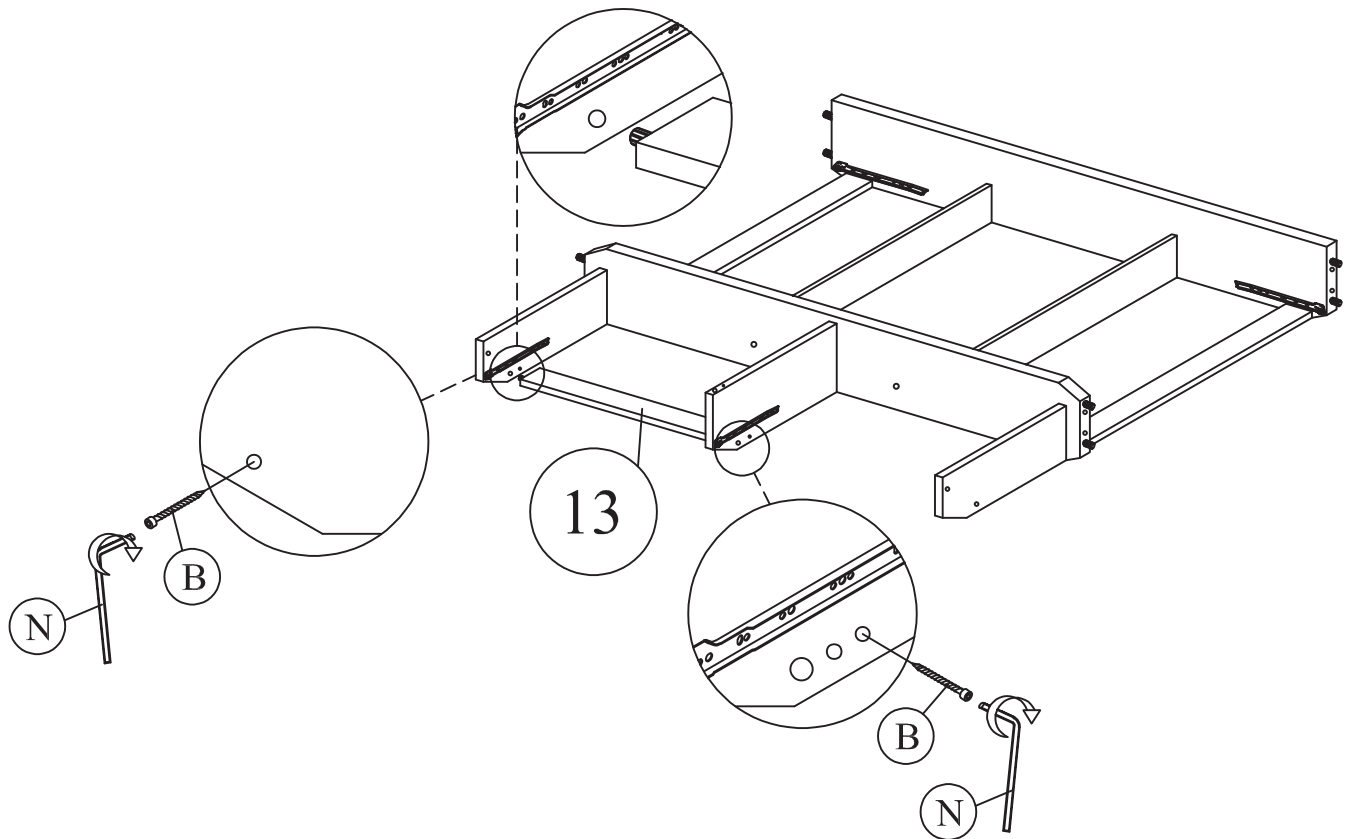

23

I x1



Ø 4 x 32mm

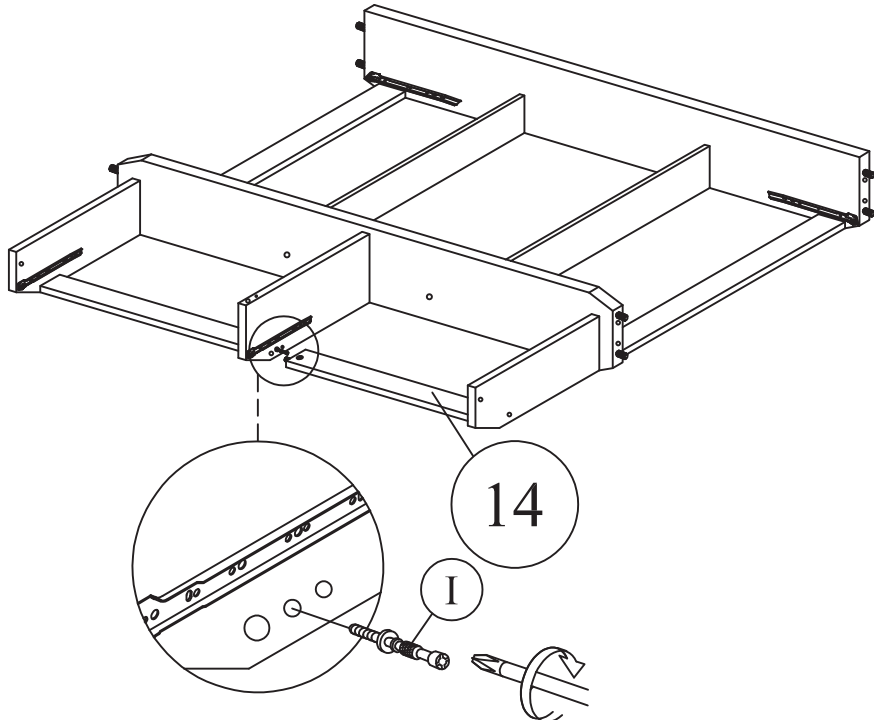

24

J x1



Ø 12 x 10mm

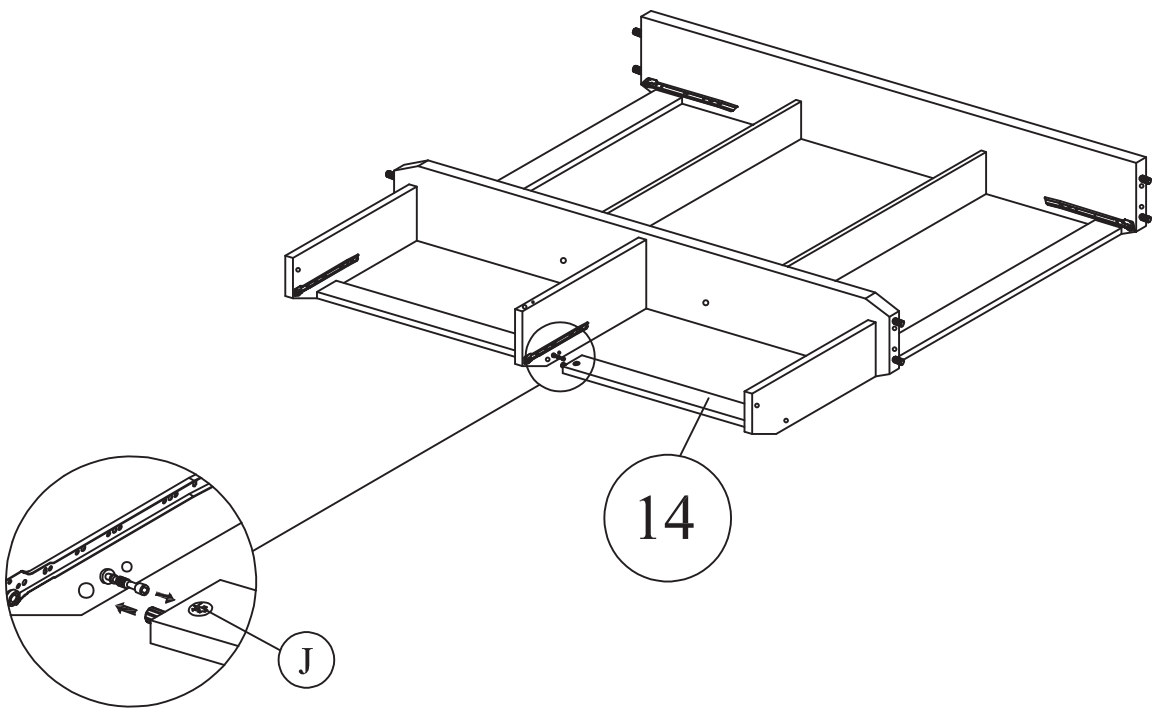

25

N x1
M4 x 65mm

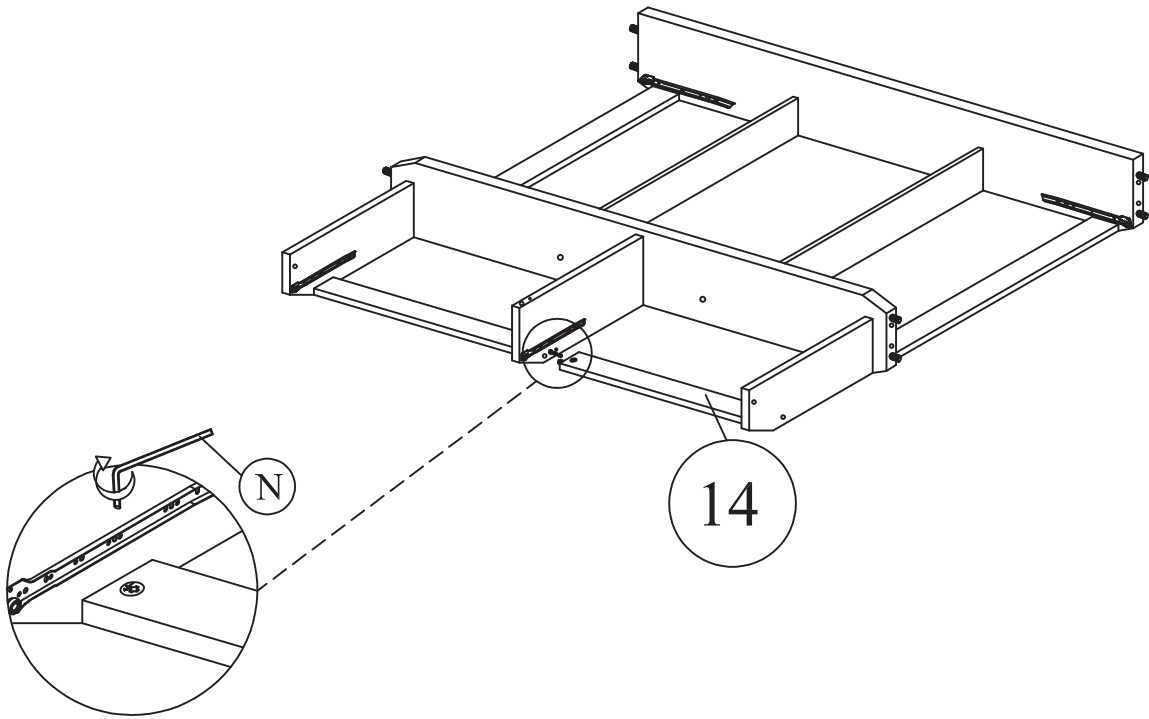

26

K x1
Ø 15mm

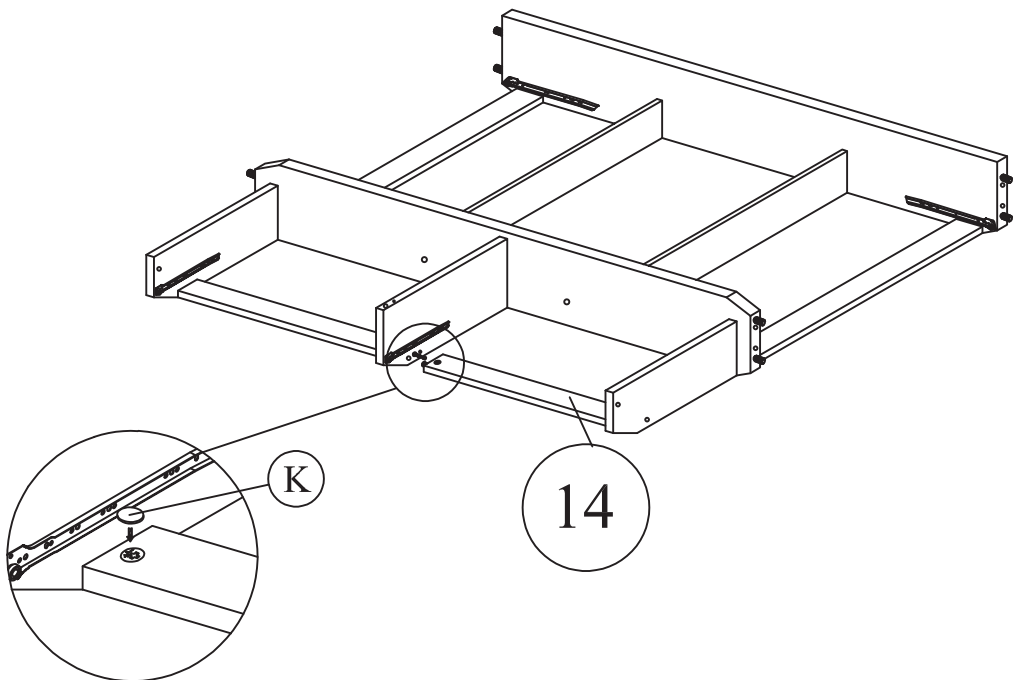

27

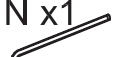
B x1  JCBC W M6 x 40mm	N x1  M4 x 65mm
--	---

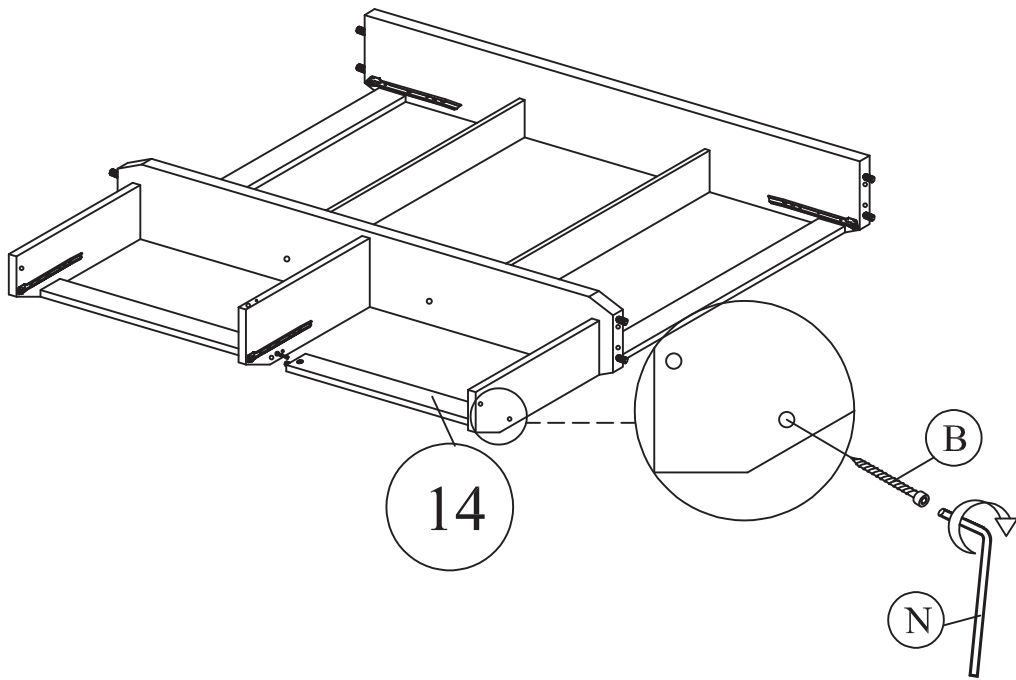

28

A x1  8x25mm	I x1  Ø 4 x 32mm	
--	--	---

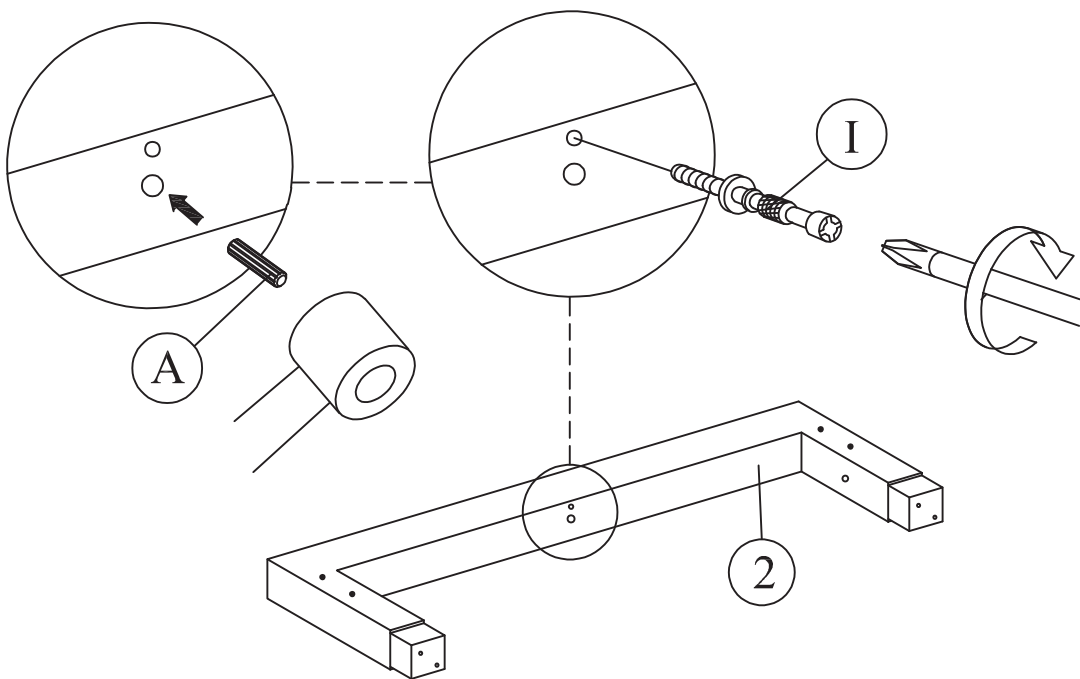

29

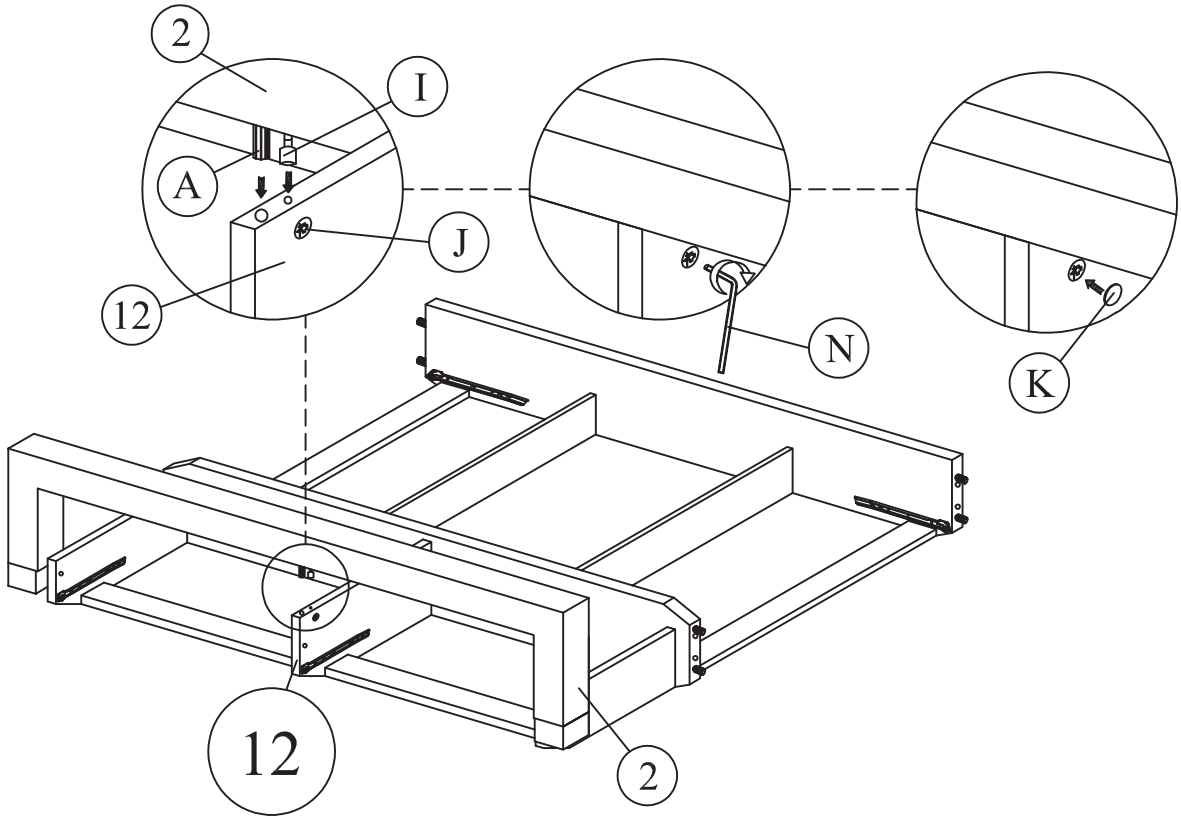
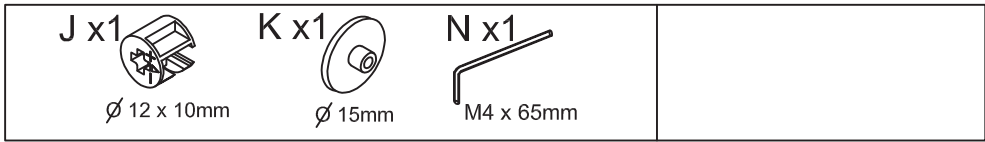

30

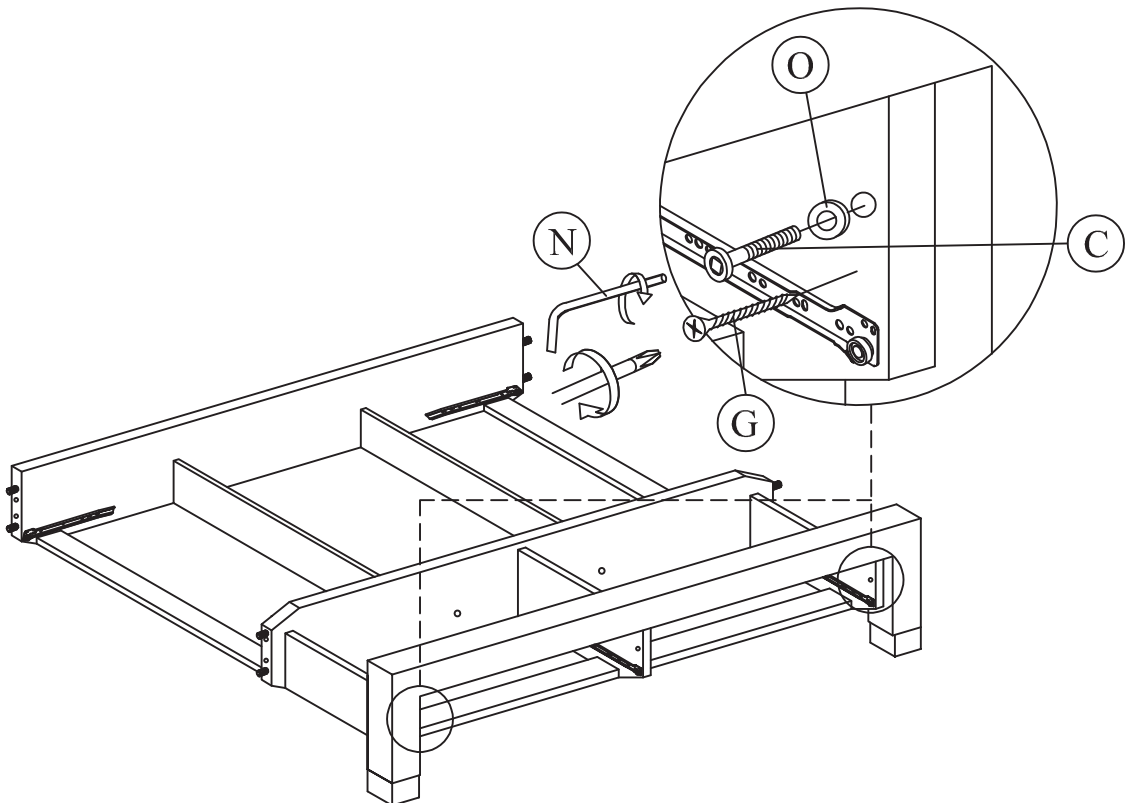
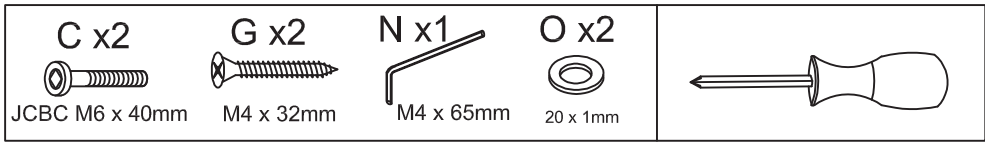

31

I x 8



Ø 4 x 32mm

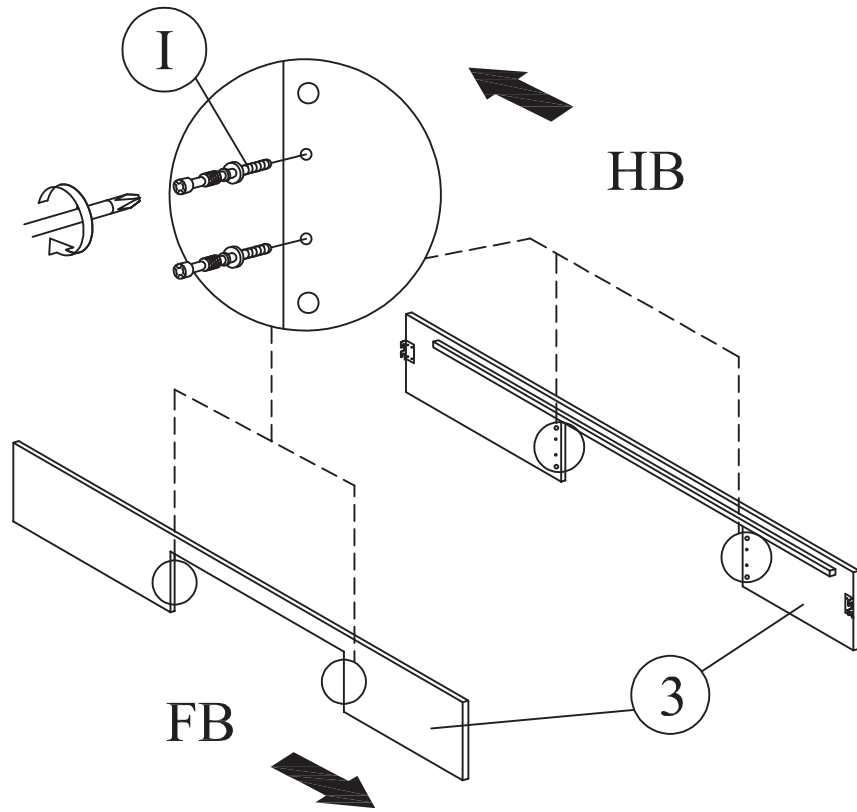
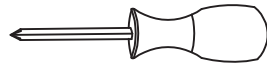

32

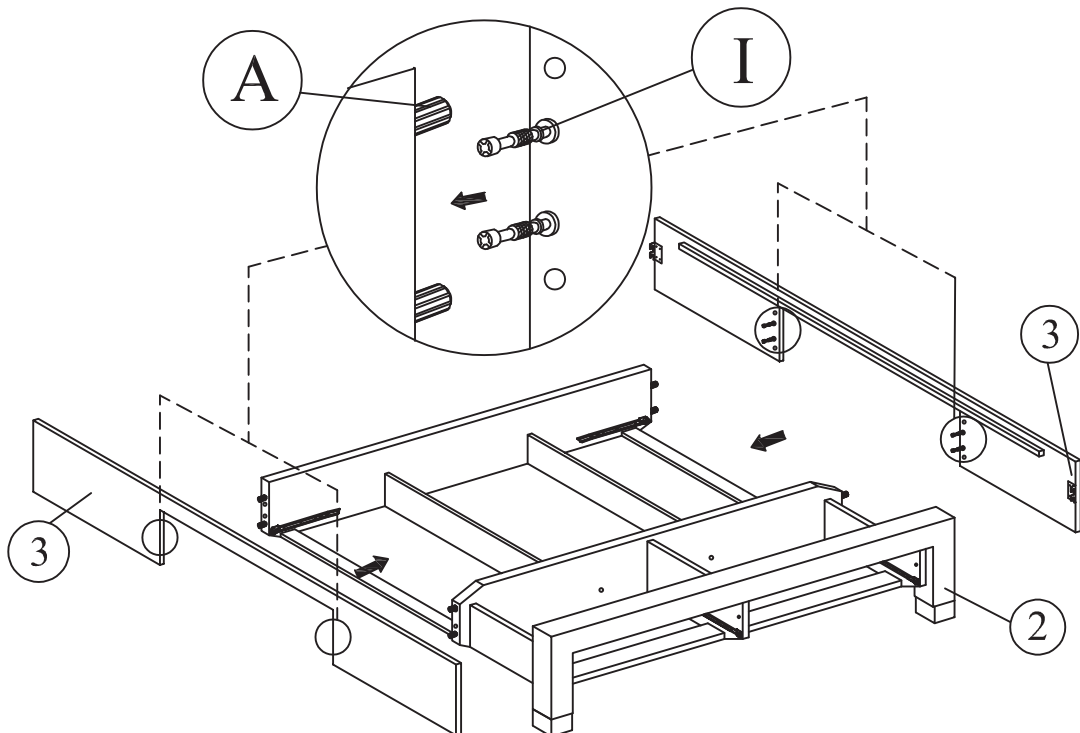

33

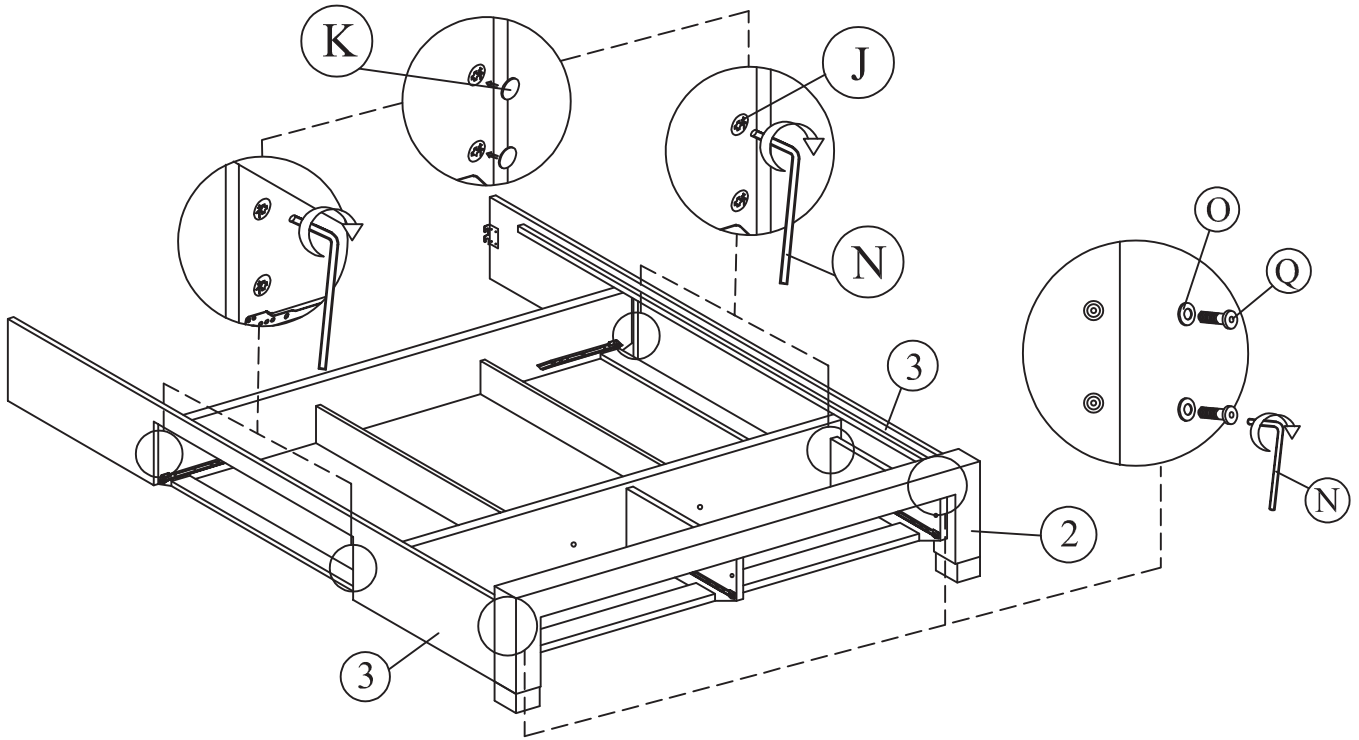
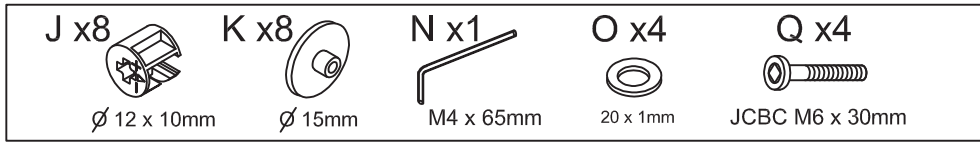

34

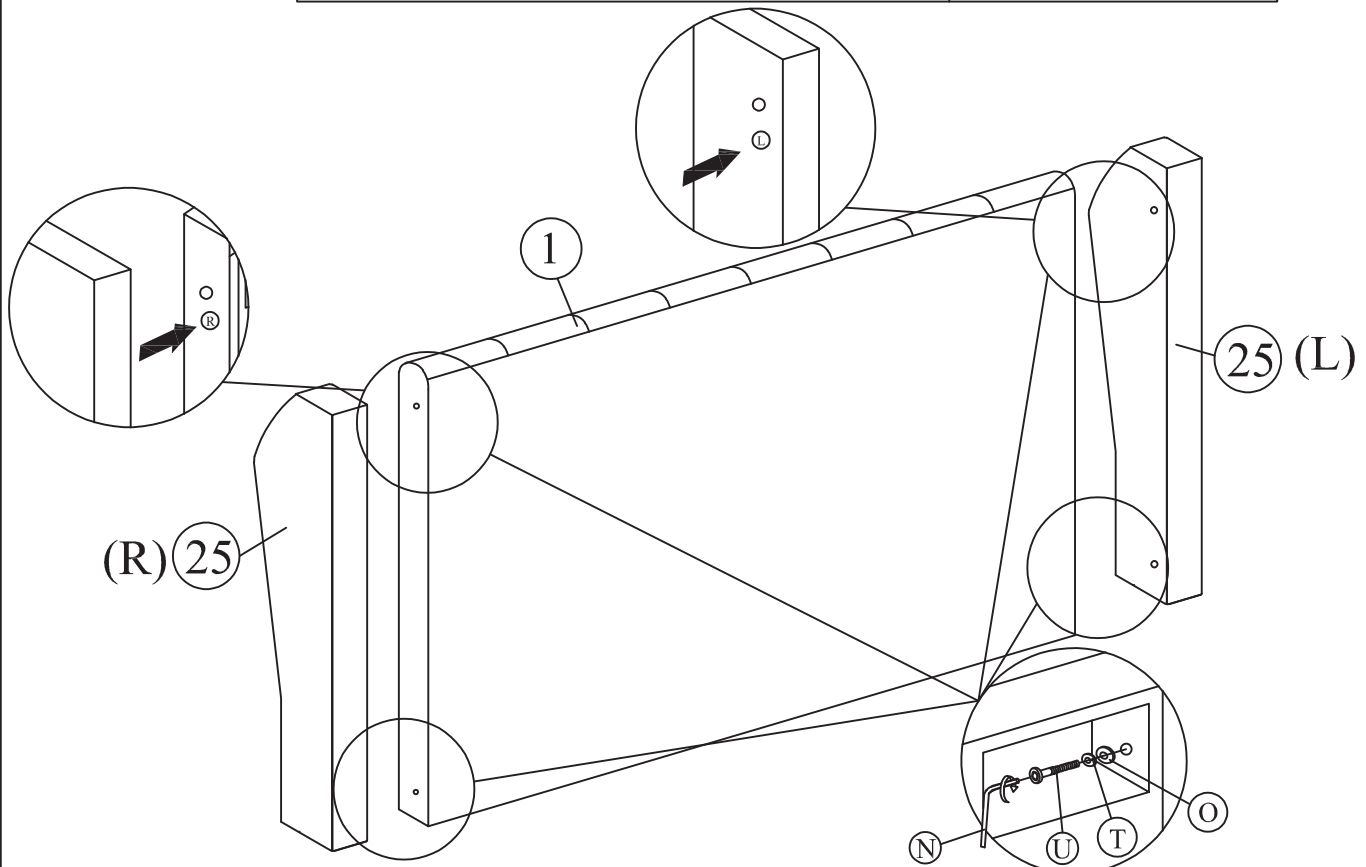
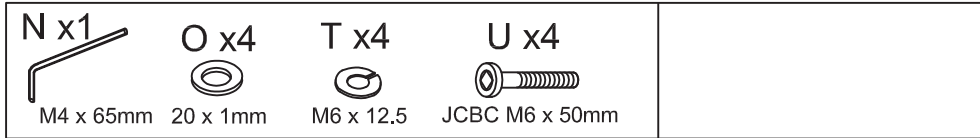

35

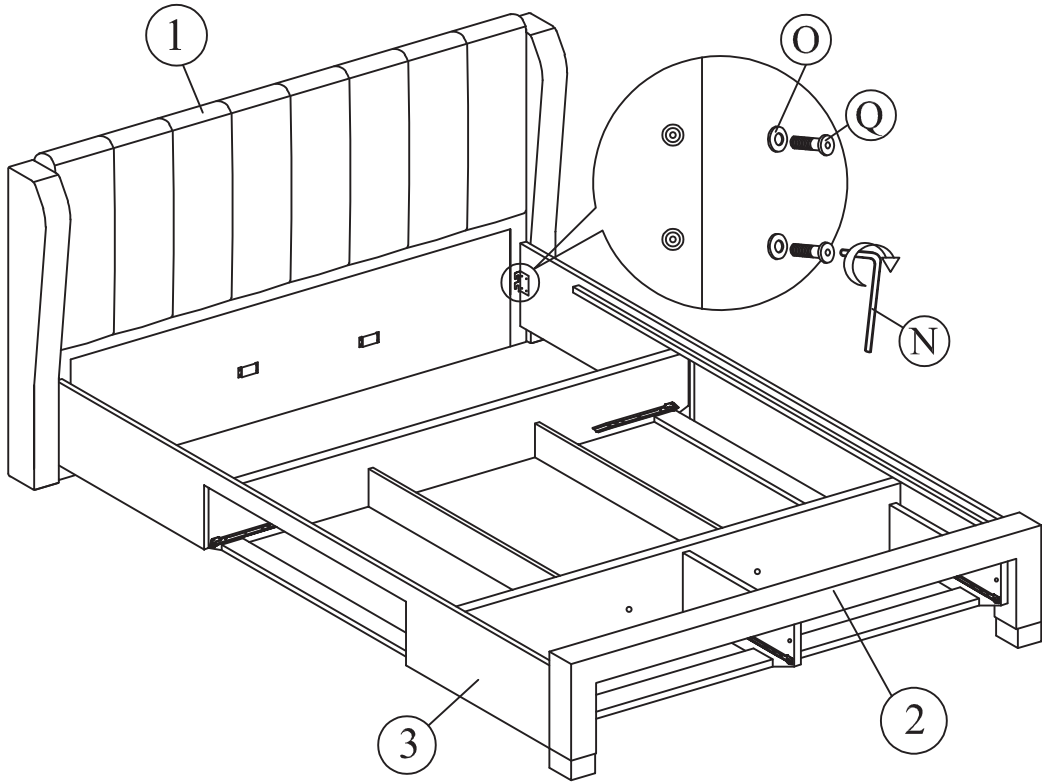
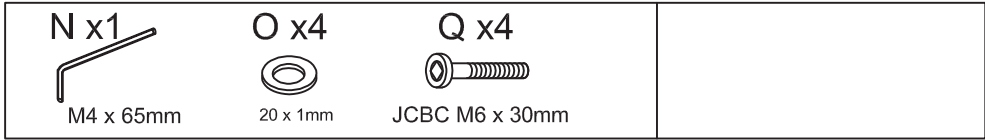

36

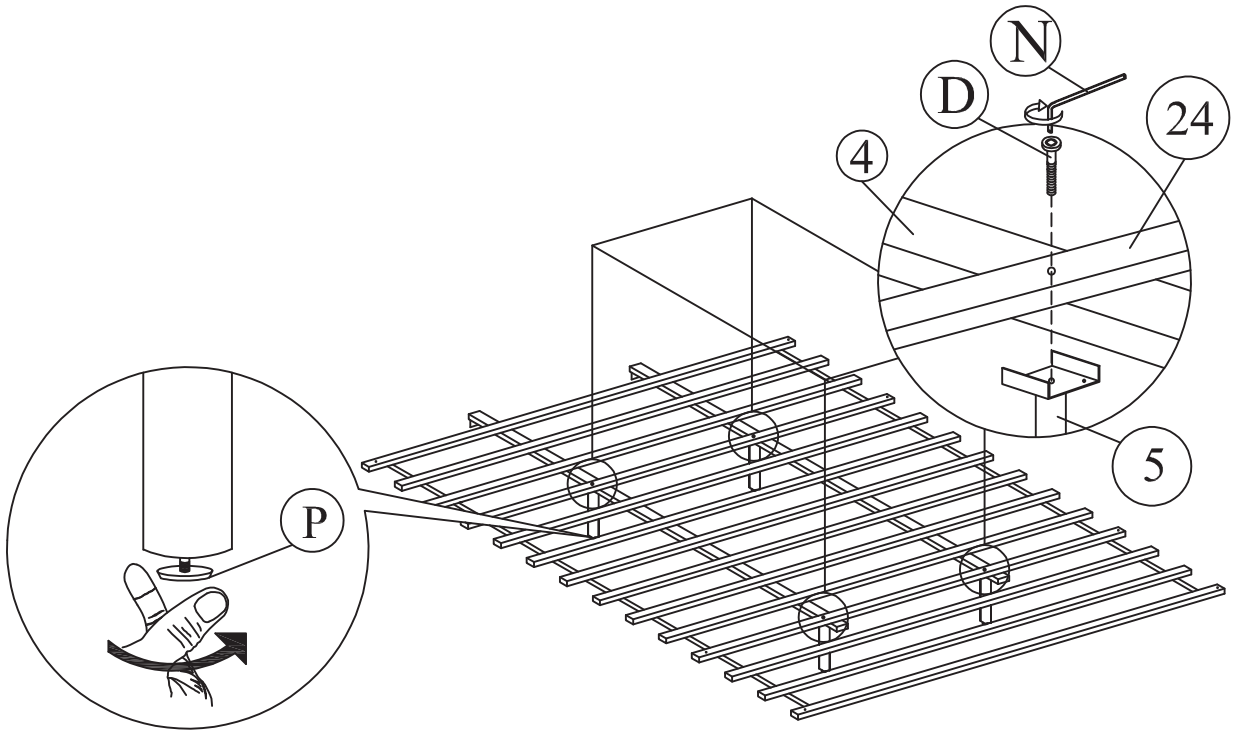
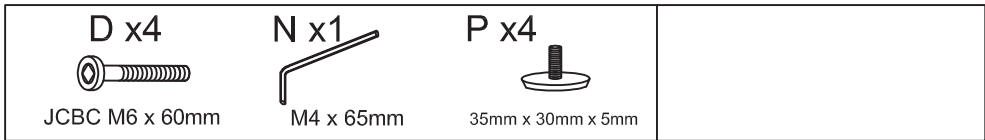

37

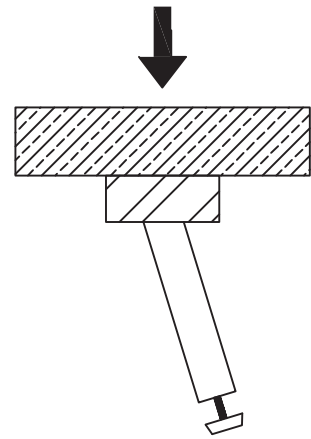
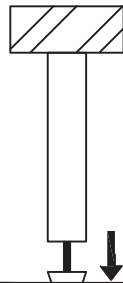
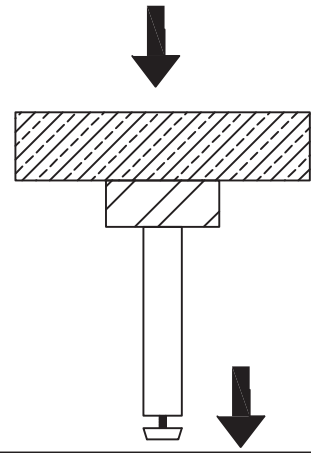
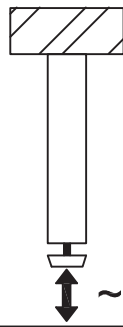

38

C x8

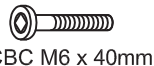

JCBC M6 x 40mm

F x2



M4 x 25mm

N x1



M4 x 65mm



4

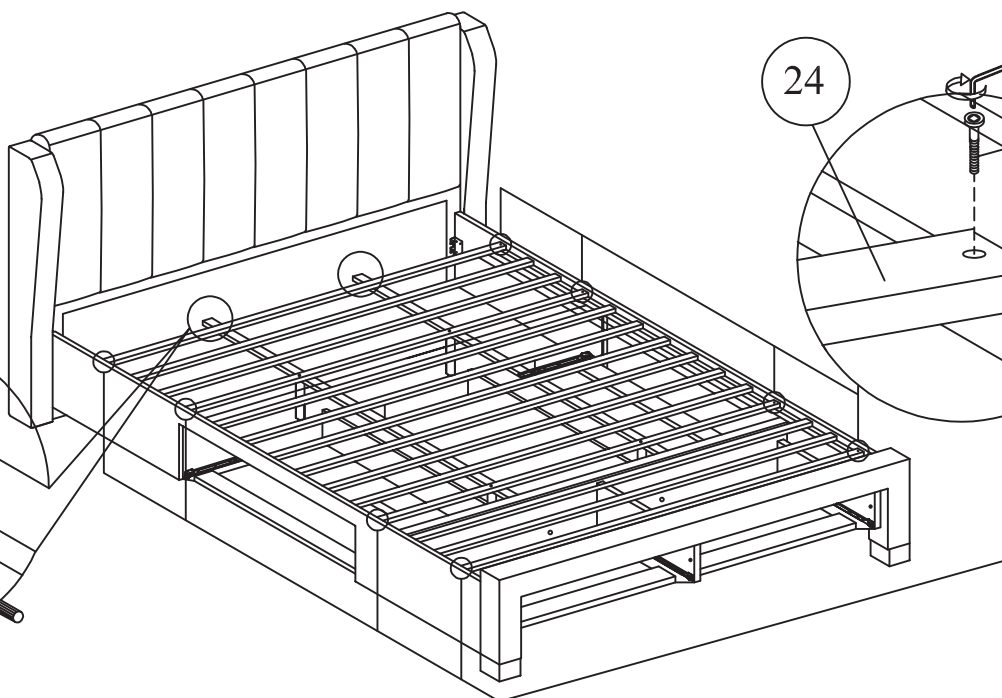
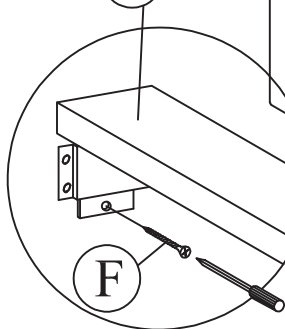

39

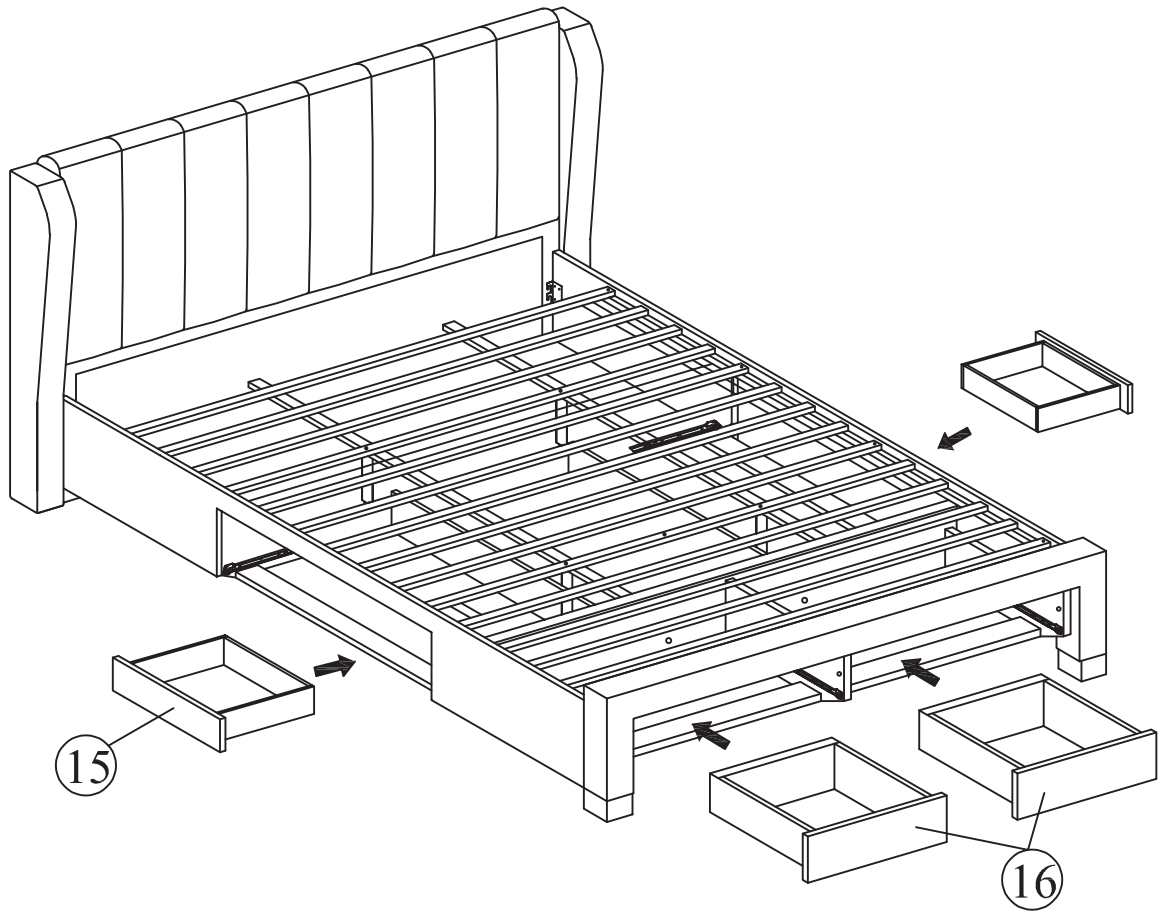

40

