

STEINKJER

136801/
901-256-1054

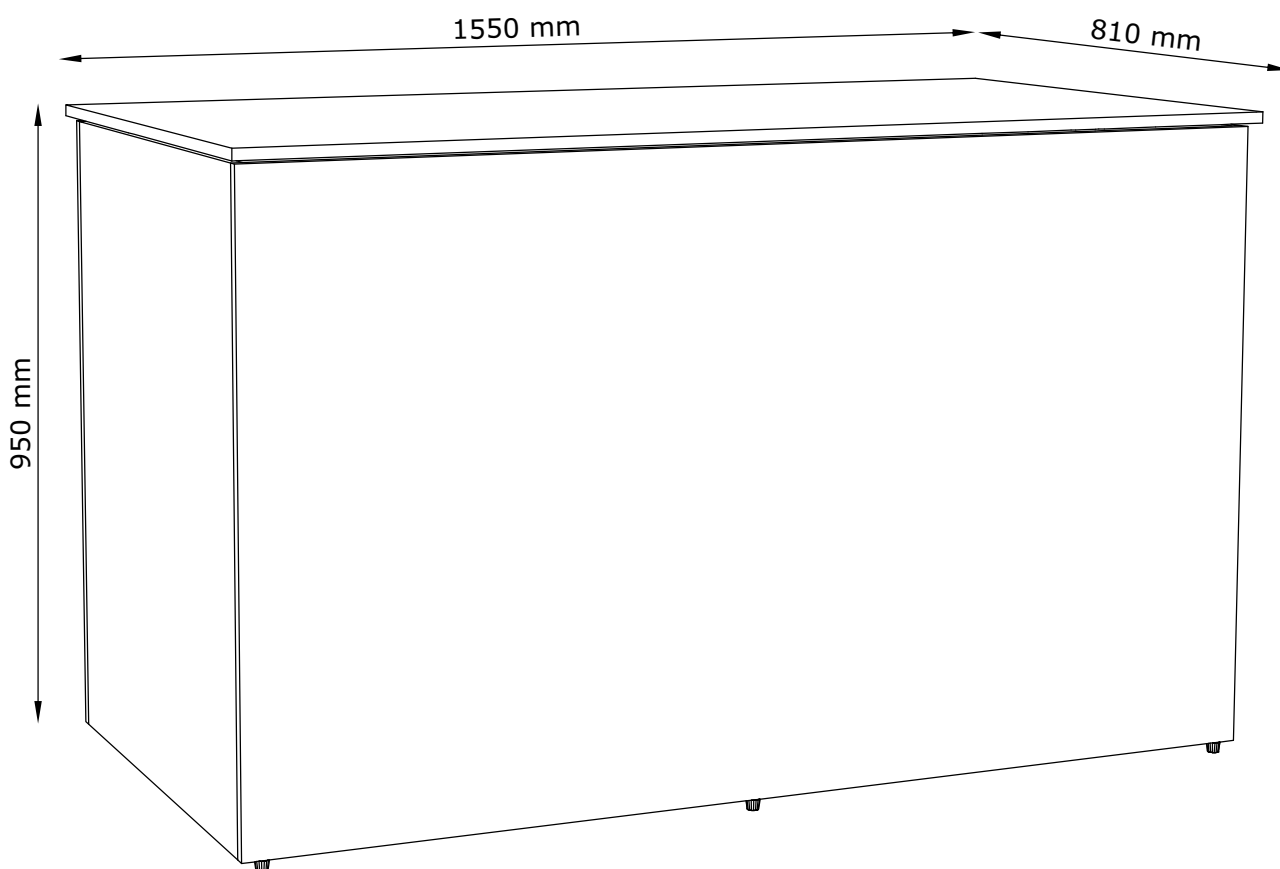

FR
Donnez ou recyclez
vos meubles.



Association

ou



Magasin

ou



Déchèterie

<https://quefairedemesdechets.fr>



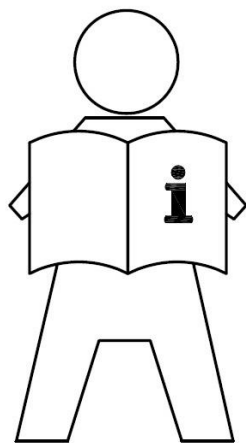

EN: IMPORTANT INFORMATION!

Please read the entire manual carefully before starting to assemble and/or using this product. Follow the manual thoroughly and keep it for further reference.

FR: INFORMATIONS IMPORTANTES

Veillez lire attentivement l'ensemble du manuel avant de commencer à monter et/ou utiliser ce produit. Suivez rigoureusement le manuel et conservez-le pour toute consultation ultérieure.

LV: SVARĪGA INFORMĀCIJA!

Pirms šī izstrādājuma montāžas un/vai lietošanas uzsākšanas pilnībā izlasiet lietošanas pamācību. Stingri ievērojiet pamācības norādījumus un saglabājiet to turpmākai lietošanai.

LT: SVARBI INFORMACIJA!

Prieš pradėdami montuoti gaminį ir (arba) juo naudotis, prašome atidžiai perskaityti visą vadovą. Atidžiai skaitykite vadovą ir turėkite jį su savimi, kad galėtumėte toliau vadovautis jo nuorodomis.

EE: OLULINE TEAVE!

Enne kui alustate toote kokku panemist ja/või kasutamist, lugege see kasutusjuhend hoolikalt läbi. Järgige täpselt juhendis toodud juhiseid ja hoidke juhend alles.

RU: ВАЖНАЯ ИНФОРМАЦИЯ!

Внимательно и полностью прочитайте это руководство, прежде чем приступать к сборке или использованию этого изделия. Следуйте всем инструкциям этого руководства и сохраните его на будущее для справки.

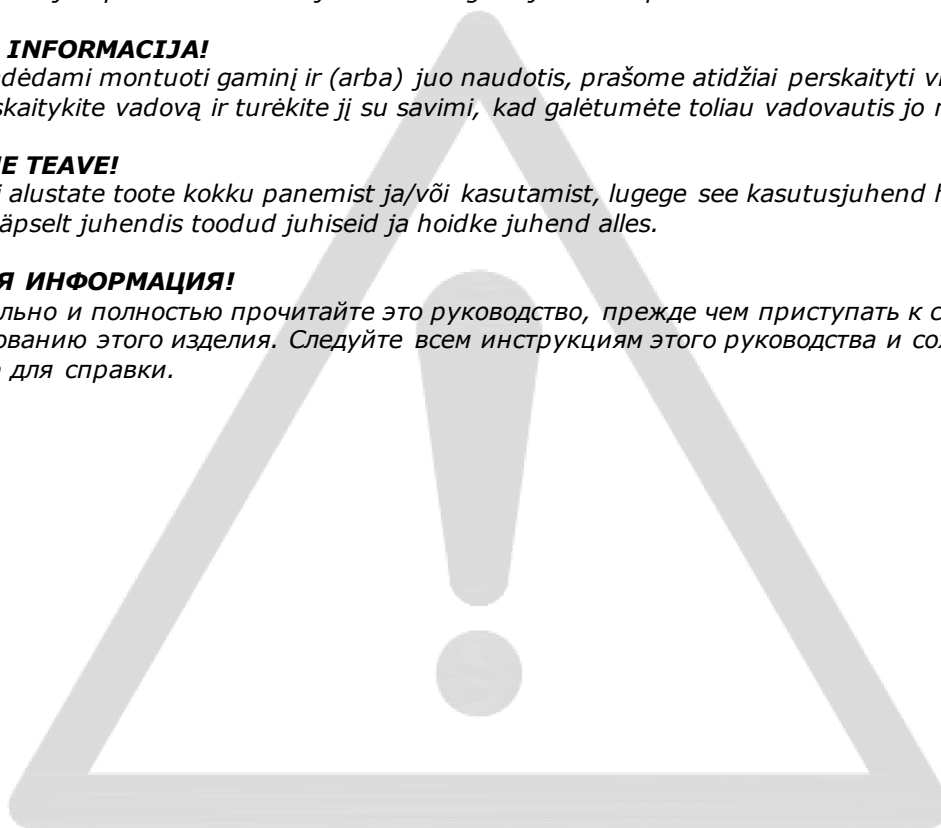

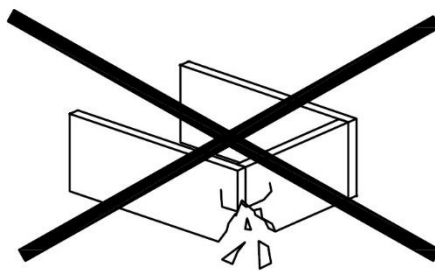
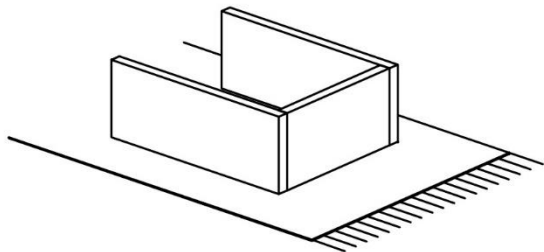

EN: WARNING TO AVOID SCRATCHES!

In order to avoid scratching this furniture should be assembled on a soft layer - could be a rug.

FR: AVERTISSEMENT POUR ÉVITER LES RAYURES

Afin d'éviter les rayures, ce meuble doit être monté sur une surface souple (un tapis, par exemple).

LV: BRĪDINĀJUMS PAR SKRĀPĒJUMIEM!

Lai nesaskrāpētu šo izstrādājumu, veiciet montāžu uz mīkstas pamatnes, piemēram, paklāja.

LT: ĮSPĖJIMAS, KAD IŠVENGTUMĖTE ĮBRĖŽIMŲ!

Šio baldo nesubraižysite, jei jį surinksite ant švelnaus paviršiaus, pavyzdžiui, kilimo.

EE: HOIATUS KRIIMUSTUSTE VÄLTIMISEKS!

Kriimustuste tekkimise vältimiseks mööblile tuleb see kokku panna pehmel pinnal, nt kaltsuvaibal.

RU: ПРЕДУПРЕЖДЕНИЕ ОТНОСИТЕЛЬНО ЦАРАПИН!

Во избежание нанесения царапин, сборку этой мебели необходимо выполнять на мягкой поверхности, например на ковре.



EN: IMPORTANT!

It is important that any product which is assembled using any kind of screw is re-tightened 2 weeks after assembly, and once every 3 months - in order to assure stability through-out the lifespan of the product.

FR: IMPORTANT

Il est important que tout produit monté à l'aide de vis soit resserré 2 semaines après son montage, puis tous les 3 mois, afin de garantir sa stabilité durant tout son cycle de vie.

LV: SVARĪGI!

Ir svarīgi, lai jebkuram produktam, kas tiek uzstādīts ar jebkādu skrūvju palīdzību, skrūves tiktu atkārtoti pievilktas 2 nedēļas pēc montāžas, pēc tam – reizi 3 mēnešos, tā nodrošinot stabilitāti visā izstrādājuma kalpošanas laikā.

LT: SVARBU!

Bet kokį varžtais tvirtinamą gaminį 2 savaites po surinkimo bei kas 3 mėnesius reikia papildomai suveržti – taip užtikrinamas naudojamo gaminio stabilumas.

EE: TÄHTIS!

Oluline on, et toote kruvisid pingutataks 2 nädalat pärast kokkupanekut ja seejärel iga 3 kuu järel, et tagada stabiilsus kogu toote eluea jooksul.

RU: ВАЖНО!

В любом изделии, собранном с использованием винтов любого типа, необходимо через 2 недели после сборки и в дальнейшем каждые 3 месяца подтягивать винты, чтобы обеспечить прочность изделия в течение срока эксплуатации.





EN: GENERAL INSTRUCTION FOR FURNITURE SURFACES!

*Wipe clean with a damp cloth. Use only water or a gentle detergent.
Wipe dry with a clean cloth.*

FR: INSTRUCTIONS GÉNÉRALES POUR LE MOBILIER

*Nettoyer à l'aide d'un chiffon humide. Utiliser uniquement de l'eau ou un détergent doux.
Essuyer à l'aide d'un chiffon propre.*

LV: VISPĀRĪGI KOPŠANAS NORĀDĪJUMI MĒBEĻU VIRSMĀM!

*Noslaukiet ar mitru drānu. Lietojiet tikai ūdeni vai maigu mazgāšanas līdzekli.
Nosusiniet ar tīru drānu.*

LT: BENDRIEJI NURODYMAI DĖL BALDŲ PAVIRŠIŲ!

*Valykite drėgnu skudurėliu. Naudokite tik vandenį arba švelnų valiklį.
Nusausinkite švarių skudurėliu.*

EE: ÜLDISED JUHISED MÖÖBLIPINDADE JAOKS!

*Kasutage puhastamiseks niisket lappi. Kasutage ainult vett või õrnatoimelist puhastusvahendit.
Pühkige puhta lapiga kuivaks.*

RU: ОБЩИЕ ПРАВИЛА ЭКСПЛУАТАЦИИ МЕБЕЛЬНЫХ ПОВЕРХНОСТЕЙ!

*Очистите изделие чистой влажной тканью. Используйте мягкодействующее моющее средство.
Вытрите досуха чистой тряпкой.*

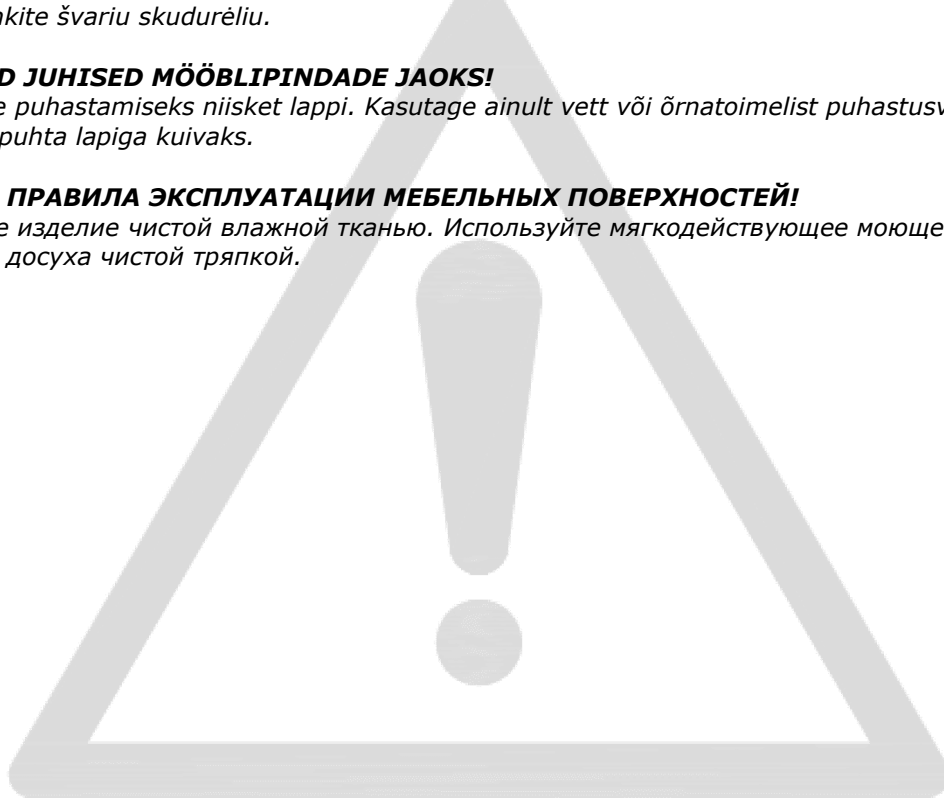

EN: WARNING FOR FINGER ENTRAPMENT:

Be cautious of potential finger entrapment hazards when assembling, using, adjusting or disassembling the product, due to its moving parts.

The product must only be used by children under adult supervision.

FR: AVERTISSEMENT RISQUE PINCEMENT DES DOIGTS:

En raison de pièces mobiles, merci de bien faire attention au risque de pincement de doigts lors de l'assemblage, de l'utilisation, du réglage ou du démontage du produit.

Le produit ne doit être utilisé par des enfants que sous la surveillance d'un adulte.

LV: BRĪDINĀJUMS PAR PIRKSTU IESPIEŠANU:

Uzstādot, lietojot, regulējot vai izjaucot izstrādājumu, jāuzmanās no iespējama pirkstu iespiešanas riska tā kustīgo daļu dēļ.

Bērni šo izstrādājumu drīkst lietot tikai pieaugušo uzraudzībā.

LT: ĮSPĖJIMAS DĖL PIRŠTŲ ĮSTRIGIMO:

Montuodami, naudodami, reguliuodami ar išardydami gaminį dėl judančių dalių būkite atsargūs – saugokite pirštus nuo įstrigimo.

Vaikai gali naudoti gaminį tik prižiūrimi suaugusiųjų.

EE: HOIATUS SÕRMEDE VAHELEJÄÄMISE OHU EEST:

Toote kokkupanekul, kasutamisel, reguleerimisel või koost lahti võtmisel olge ettevaatlik – liikuvatest osadest tulenev sõrmede vahelejäämise oht.

Toodet tohivad kasutada ainult lapsed täiskasvanu järelevalve all.

RU: ПРЕДУПРЕЖДЕНИЕ ОБ ОПАСНОСТИ ЗАЩЕМЛЕНИЯ ПАЛЬЦЕВ:

При сборке, использовании, регулировке или разборке изделия соблюдайте осторожность, поскольку движущиеся элементы изделия могут защемить пальцы.

Дети могут использовать изделие только под наблюдением взрослых.

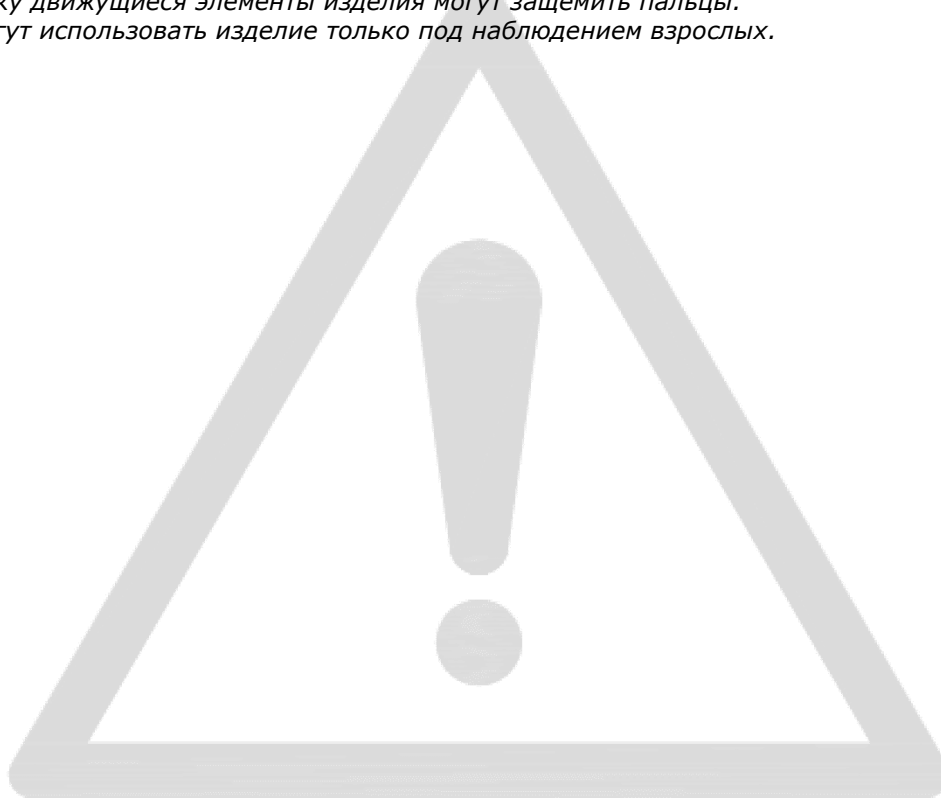



EN: GENERAL INSTRUCTION FOR FURNITURE WITH FABRIC!

Wipe clean with a damp cloth. Use only clean water.

Dust and dirt can be vacuum cleaned or wiped with a clean soft cloth.

Do not use detergents, solvents or other chemicals on fabric as this may cause discoloration.

However, certain removable fabrics may be washed, but in such cases there will ALWAYS be a washing instruction on the fabric.

FR: INSTRUCTIONS GÉNÉRALES POUR LE MOBILIER EN TISSU!

Nettoyez à l'aide d'un chiffon humide. N'utilisez que de l'eau claire.

La poussière et la saleté peuvent être aspirées ou essuyées à l'aide d'un chiffon doux et propre.

N'utilisez aucun détergent, solvant ou autre produit chimique sur le tissu, car ceci pourrait le décolorer.

Cependant, certains tissus amovibles peuvent être lavés, mais dans ce cas le tissu comportera TOUJOURS des instructions de lavage.

LV: VISPĀRĪGI KOPŠANAS NORĀDĪJUMI MĒBELĒM AR AUDUMU!

Noslaukiet ar mitru drānu. Izmantojiet tikai tīru ūdeni.

Putekļus un netīrumus var notīrīt ar putekļusūcēju vai noslaucīt ar mīkstu drānu.

Auduma tīrīšanai neizmantojiet mazgāšanas līdzekļus, šķīdinātājus vai citas ķīmikālijas, jo auduma krāsa var izbalēt.

Atsevišķus noņemamos audumus var mazgāt, taču tad uz auduma VIENMĒR būs sniegti kopšanas norādījumi.

LT: BENDROSIOS INSTRUKCIJOS BALDAMS PADENGTIEMS AUDINIUI!

Švariai nušluostykite drėgna šluoste. Naudokite tik švarų vandenį.

Dulkės ir nešvarumai gali būti susiurbti arba nuvalyti švaria, minkšta šluoste.

Nenaudokite detergentų, tirpiklių ar kitų chemikalų audiniams, nes šie gali sukelti spalvos išblukimą.

Visgi, kai kurie nuimami audiniai gali būti skalbiami, bet tokiais atvejais ant audinio etiketės VISADA turi būti pateiktos skalbimo instrukcijos.

EE: ÜLDISED JUHISED KANGAGA MÖÖBLI JAOKS!

Puhastage niiske lapiga. Kasutage ainult puhast vett.

Tolmu ja mustust saab eemaldada tolmuimejaga või ära pühkida puhta pehme lapiga.

Ärge kasutage kangal pesuvahendeid, lahusteid või muid kemikaale, kuna see võib põhjustada värvimuutusi.

Küll aga võib teatud eemaldatavaid kangaid pesta, kuid sellisel juhul on kanga küljes ALATI pesujuhend.

RU: ОБЩИЕ УКАЗАНИЯ ПО УХОДУ ЗА МЕБЕЛЬЮ С ОТДЕЛКОЙ ИЗ ТКАНИ!

Очистите изделие чистой влажной тряпкой. Используйте только чистую воду.

Пыль и грязь можно удалять пылесосом или чистой мягкой тряпкой.

Не наносите моющие средства, растворители или другие химические вещества на ткань, поскольку они могут привести к вымыванию цвета.

Некоторые съемные элементы из ткани можно стирать. В таких случаях к ткани ОБЯЗАТЕЛЬНО прилагается инструкция по стирке.

- EN:** *It is recommended to only store cushions in the box during the summer season. Autumn and winter weather may result in the cushions becoming damp, which, in the worst case, may cause mildew formation on the fabric. The cushions may also become damp as a result of heavy rains, in which case subsequent air-drying is recommended.*
- FR:** *Il est recommandé de ne stocker les coussins dans le coffre que pendant l'été. Le climat de l'automne et de l'hiver risque d'humidifier les coussins, voire de causer des moisissures du tissu. Si les coussins ont été mouillés à la suite de fortes pluies, un séchage à l'air chaud est recommandé.*
- LV:** *Spilvenus ir ieteicams uzglabāt kastē tikai vasaras sezonā. Rudenī un ziemā spilveni var kļūt mitri – sliktākajā gadījumā tas izraisīs pelējuma veidošanos uz auduma. Spilveni var samirkēt arī spēcīgā lietū, šajā gadījumā ieteicams spilvenus izžāvēt gaisā.*
- LT:** *Rekomenduojama pagalvėles saugoti dėžėje tik vasaros sezonu. Rudeniškas ir žiemiškas oras gali pagalvėles sudrėkinti, o tai, blogiausiu atveju, gali sukelti pelėsio formavimąsi ant medžiagos. Pagalvėlės taip pat gali sušlapti esant stipriam lietuvi, tokiu atveju rekomenduojamas džiovinimas lauke.*
- EE:** *Patju on soovitatav säilitada kastis ainult suvehooajal. Sügis- ja talveilmadega võivad padjad muutuda niiskeks, mis halvimal juhul viib kangas hallituse tekkeni. Padjad võivad saada märjaks ka tugeva vihma tõttu, sellisel juhul on soovitatav neid kuivatada õhu käes.*



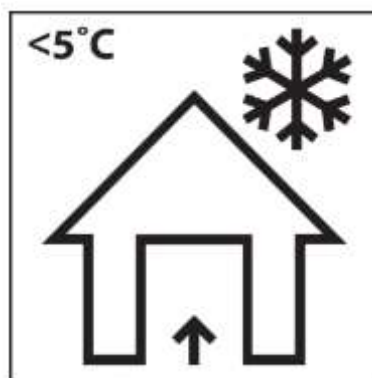

EN: Storage of garden furniture and garden products

The best way to extend the life of your garden product is to clean it regularly and before storage. Store the product in a cool, dry and ventilated place indoors or covered when the temperature is below 5 degrees Celsius or when weather conditions require it.

FR: Rangement du mobilier de jardin et des articles de jardin

Afin de prolonger la durée de vie de votre article de jardin au maximum, il est conseillé de le nettoyer régulièrement, notamment avant de le ranger.

Conservez le produit dans un endroit frais, sec et ventilé à l'intérieur ou couvert quand la température est inférieure à 5 degrés Celsius ou quand les conditions météorologiques l'exigent.

LV: Dārza mēbeļu un dārza priekšmetu uzglabāšana

Labākais veids, kā paildzināt dārza priekšmetu ekspluatācijas laiku – regulāri un pirms uzglabāšanas tos tīrīt.

Ja temperatūra ir zemāka par 5 grādiem pēc Celsija vai ja to prasa laikapstākļi, uzglabājiet produktu vēsā, sausā un vēdināmā vietā telpās vai nosegtā veidā.

LT: Sodo baldų ir sodo gaminių laikymas

Kad sodo gaminys ilgiau tarnautų, reikia jį reguliariai valyti, taip pat nuvalyti prieš sandėliavimą.

Gaminį laikykite vėsioje, sausoje ir vėdinamoje patalpoje arba uždengtą lauke, kai temperatūra žemesnė nei 5 laipsniai Celsijaus arba priklausomai nuo oro sąlygų.

EE: Aiamööbli ja -toodete hoiustamine

Parim viis oma aiatoote kasutusea pikendamiseks on seda regulaarselt ja enne hoiustamist puhastada.

Hoiustage toodet jahedas, kuivas ja ventileeritud kohas siseruumides või kaetuna, kui temperatuur on alla 5 °C või kui ilmastikutingimused seda nõuavad.

RU: Хранение садовой мебели и садовых изделий

Лучшим способом продления срока службы ваших садовых изделий является их регулярная очистка перед хранением.

Храните изделия в прохладном, сухом и проветриваемом помещении или в чехле, если температура ниже 5 градусов Цельсия или этого требуют погодные условия.

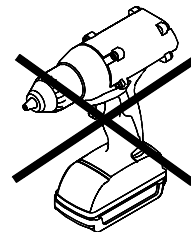

A x 12



M6x15 mm

B x 22

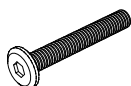

M6x40 mm

C x 22



Ø6/Ø14 mm

D x 3

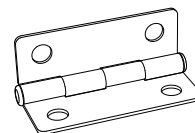

50x35x6 mm

E x 2

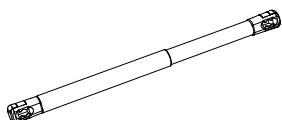

120N

F x 2

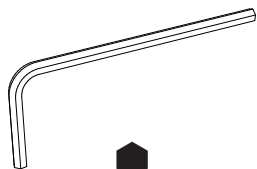

4 mm

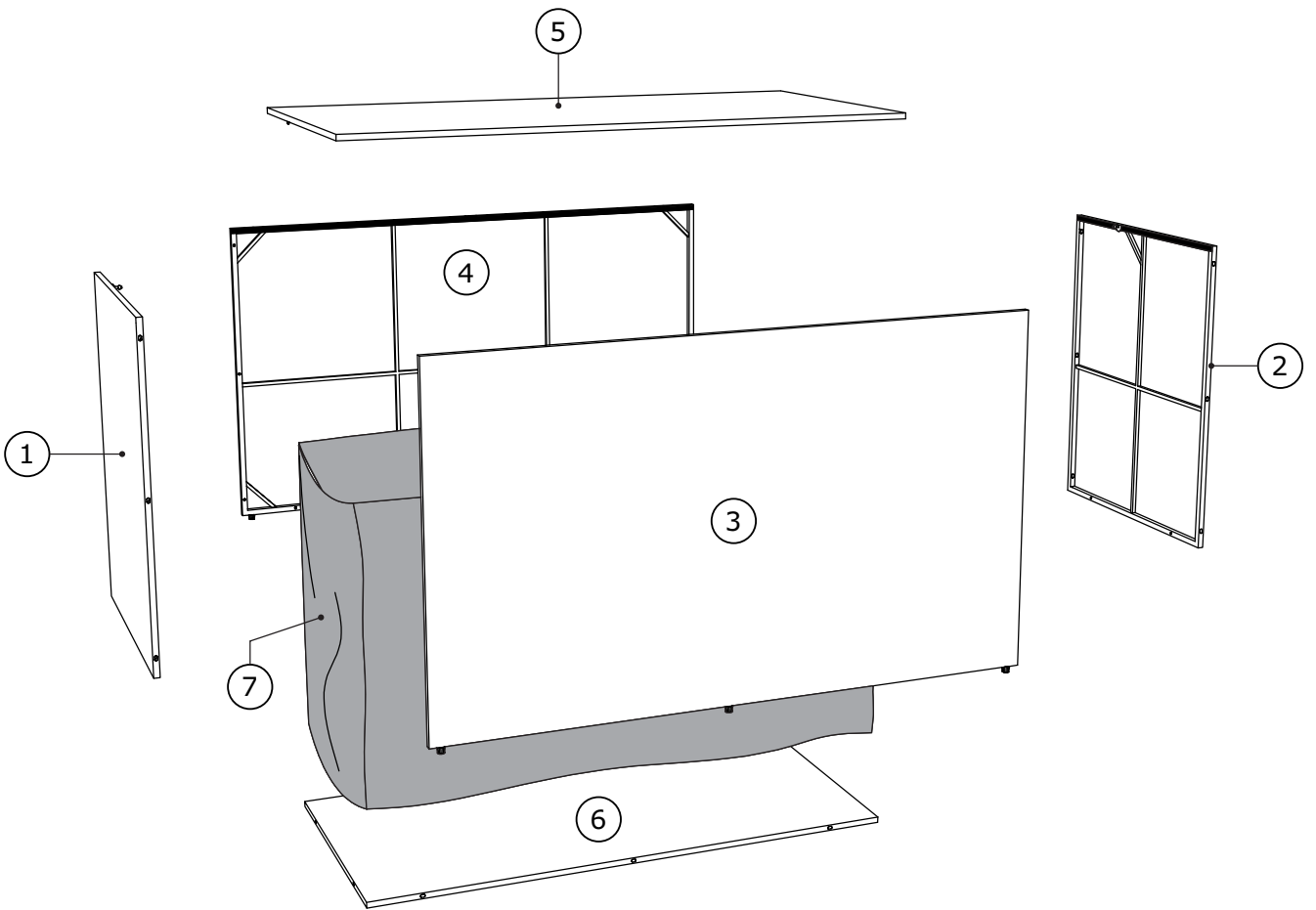

BOX 1/1:

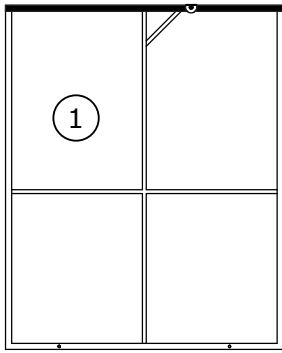

730x905x35 mm

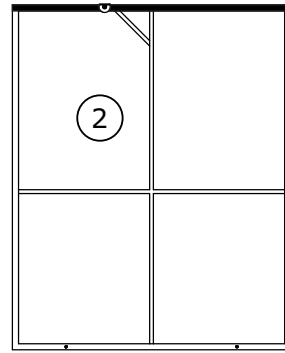

730x905x35 mm

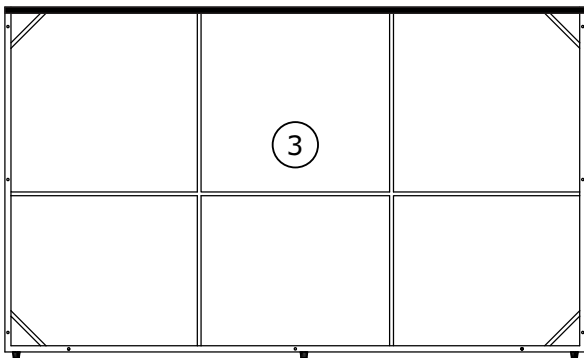

1530x920x25 mm

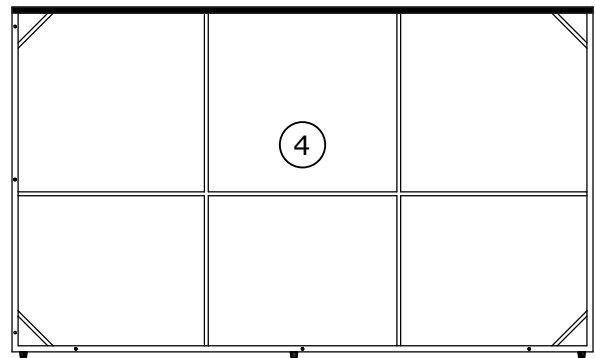

1530x920x25 mm

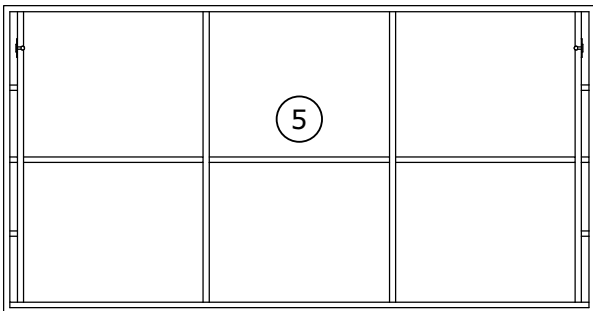

1550x810x40 mm

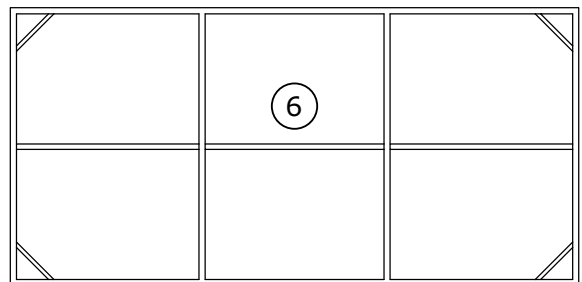

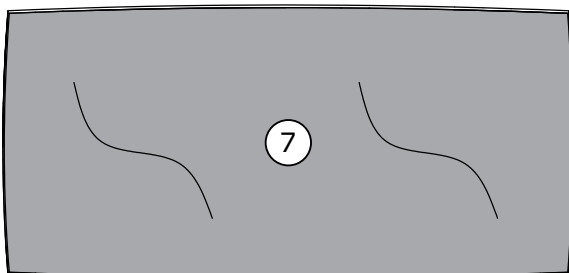

1485x730x20 mm

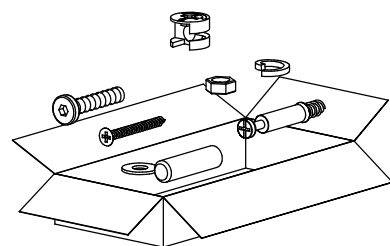

1480x735x890 mm



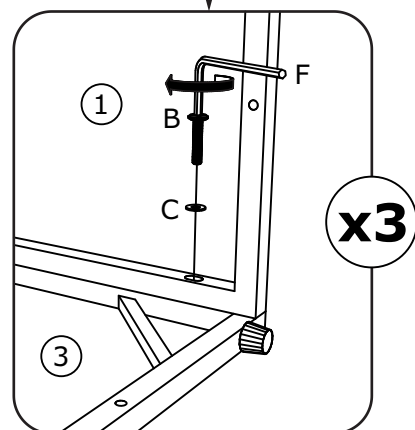
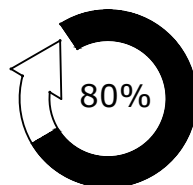
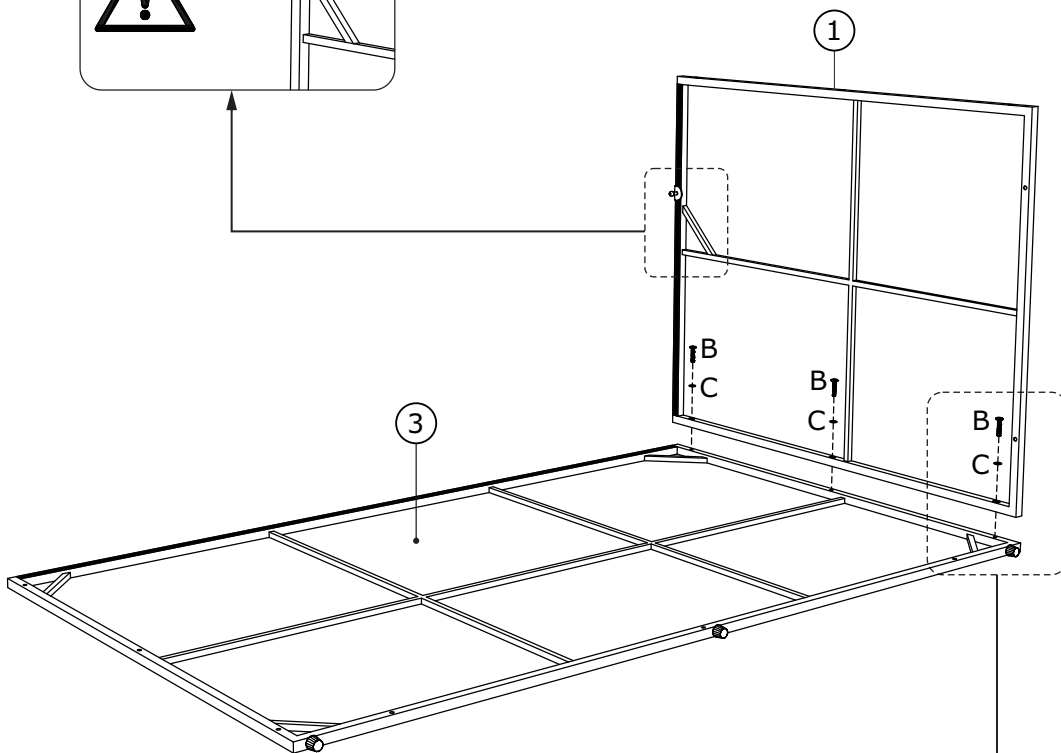
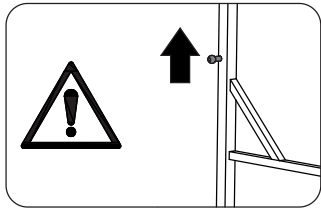
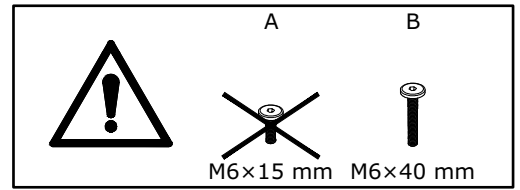

1

<p>B x 3</p>  <p>M6x40 mm</p>	<p>C x 3</p>  <p>Ø6/Ø14 mm</p>	<p>F x 1</p>  <p>4 mm</p>	
--	---	--	--



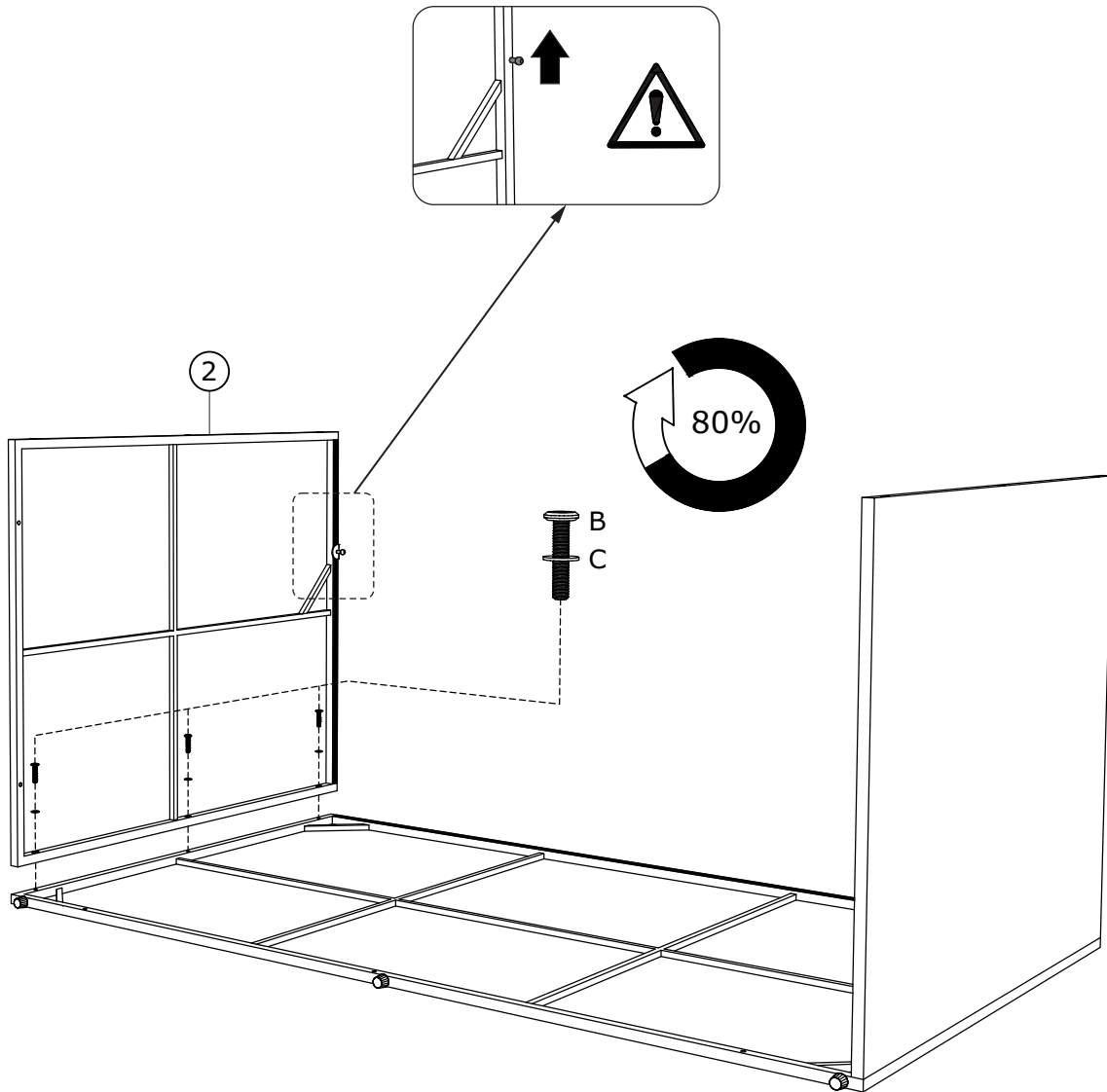
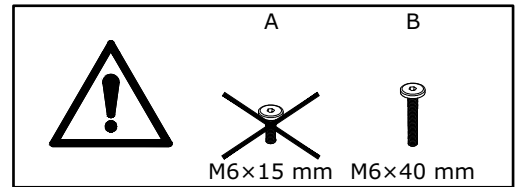

2

<p>B x 3</p>  <p>M6x40 mm</p>	<p>C x 3</p>  <p>Ø6/Ø14 mm</p>	<p>F x 1</p>  <p>4 mm</p>	
--	---	--	--



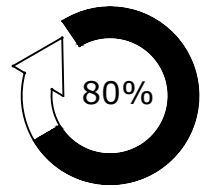
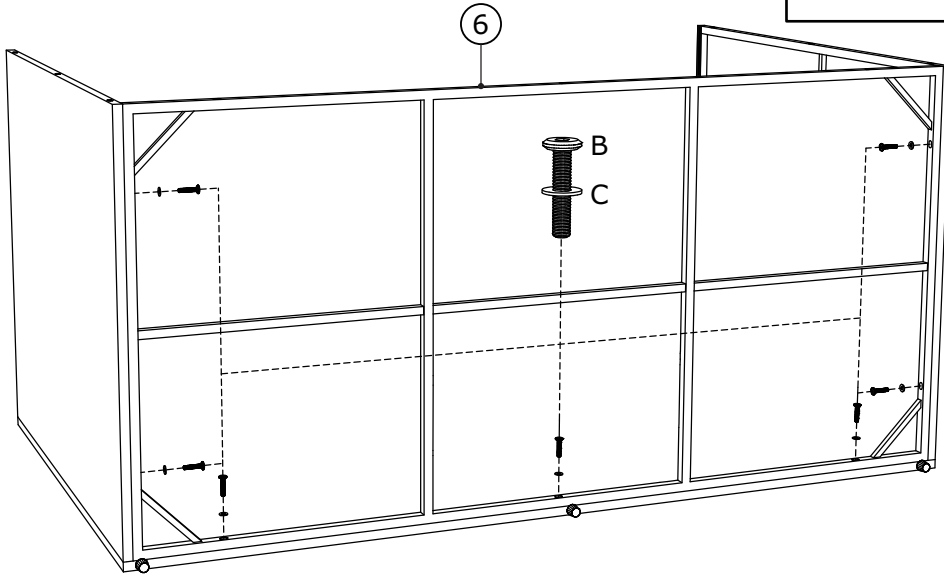
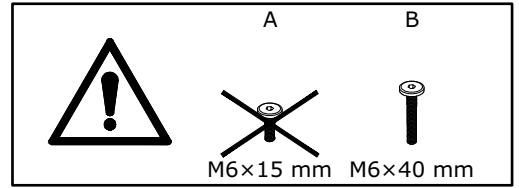

3

B x 7  M6x40 mm	C x 7  Ø6/Ø14 mm	F x 1  4 mm	
--	---	--	--



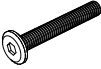

4

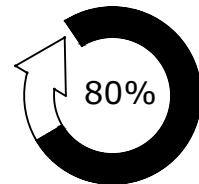
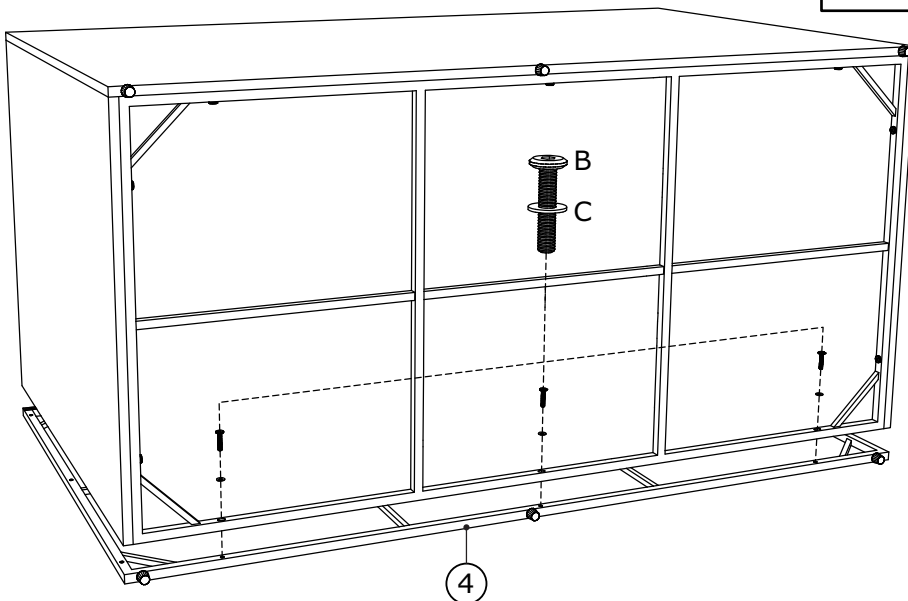
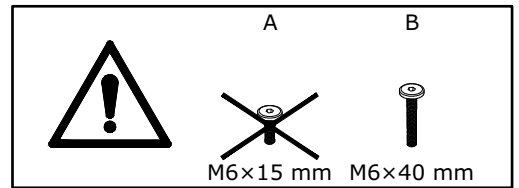
B x 3  M6x40 mm	C x 3  Ø6/Ø14 mm	F x 1  4 mm	
--	---	--	--



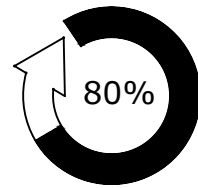
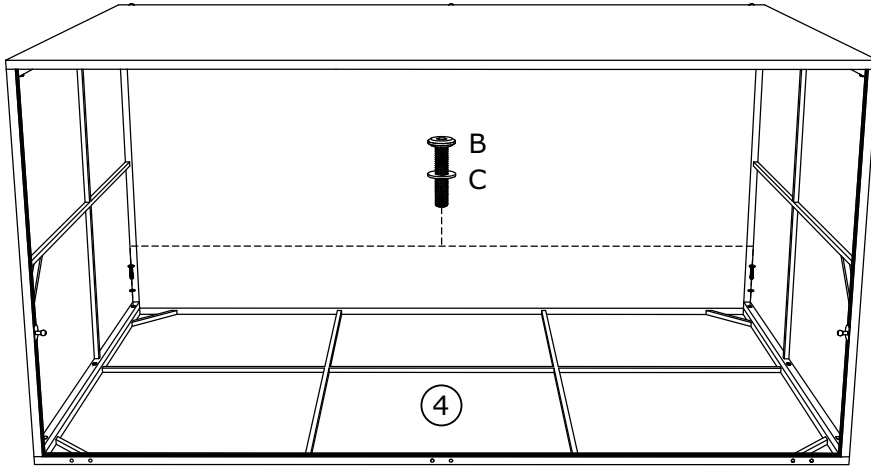
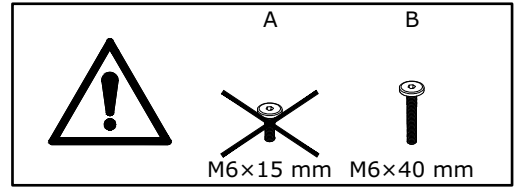

5

B x 2  M6x40 mm	C x 2  Ø6/Ø14 mm	F x 1  4 mm	
--	---	--	--

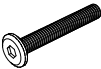

6

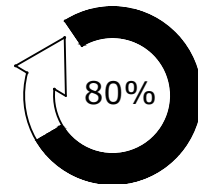
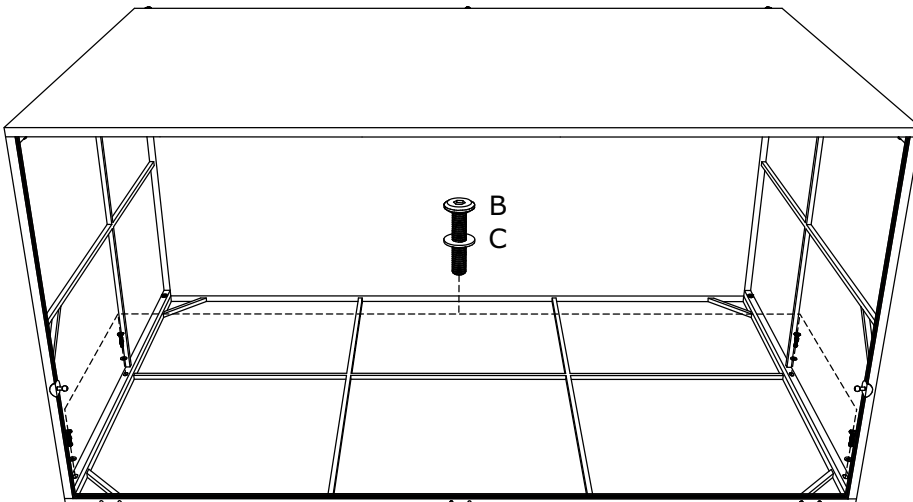
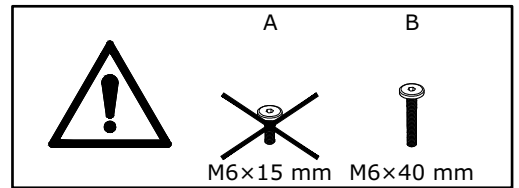

B x 4  M6x40 mm	C x 4  Ø6/Ø14 mm	F x 1  4 mm	
--	---	--	--

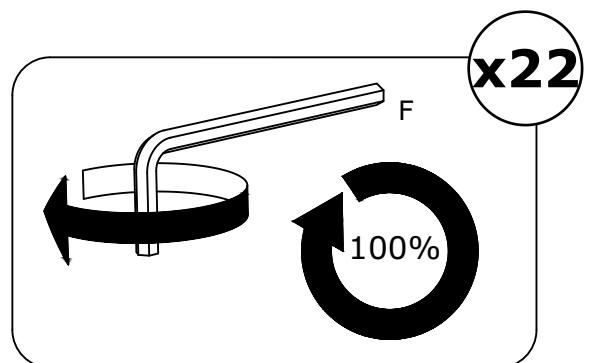
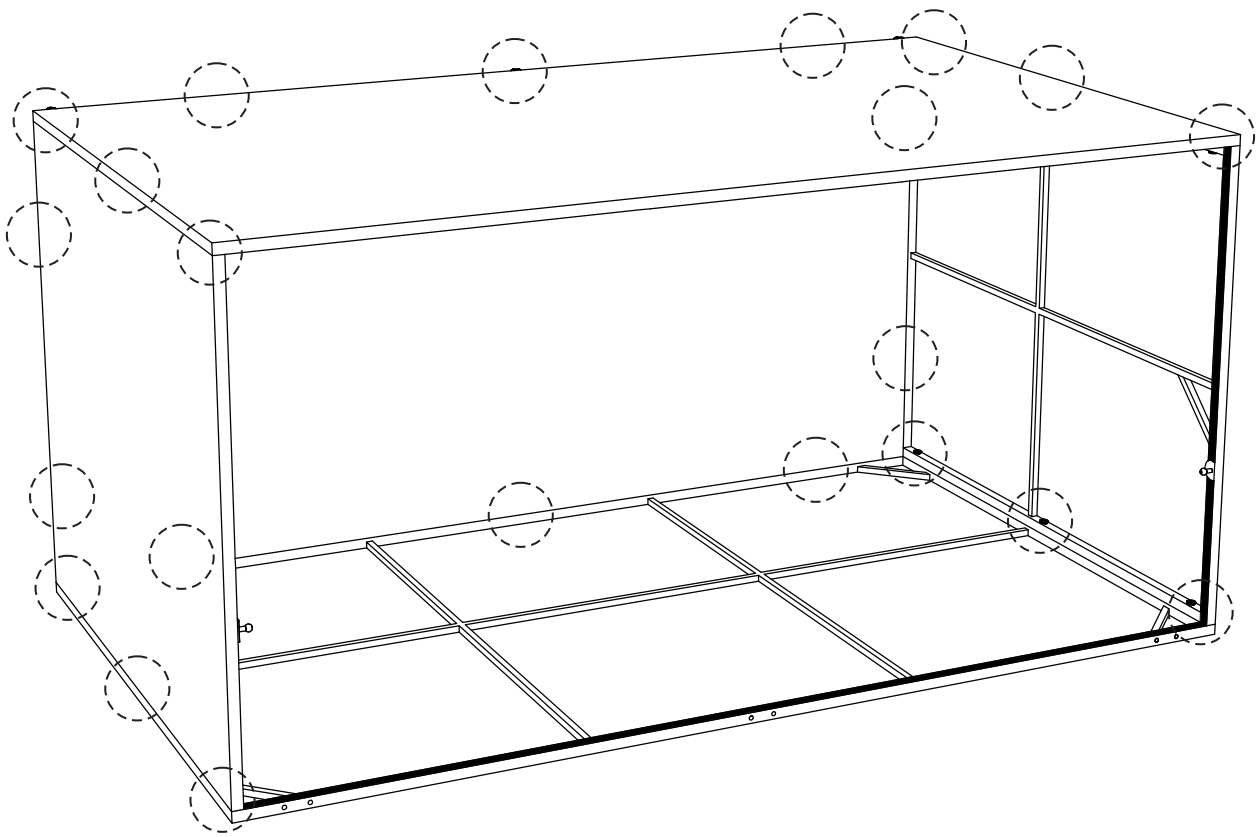

7

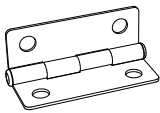

8

A x 6  M6x15 mm	D x 3  50x35x6 mm	F x 1  4 mm	
--	--	--	--

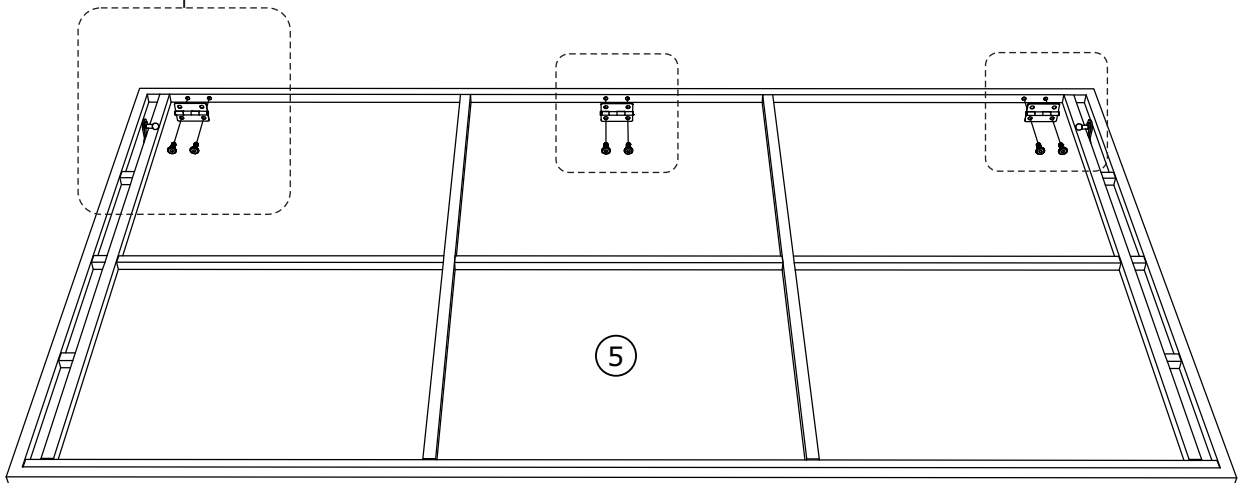
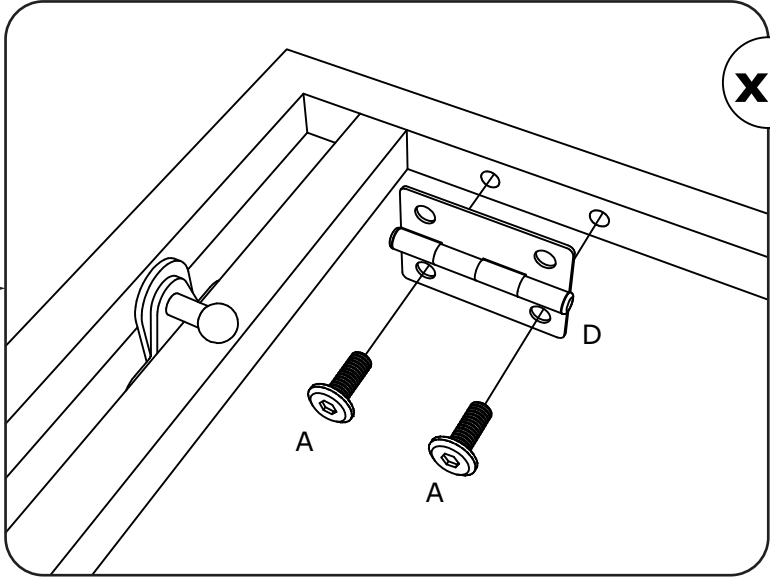
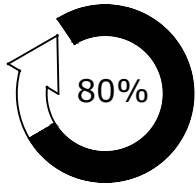

9

A x 2  M6x15 mm	F x 1  4 mm	
--	--	--

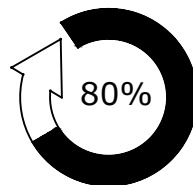
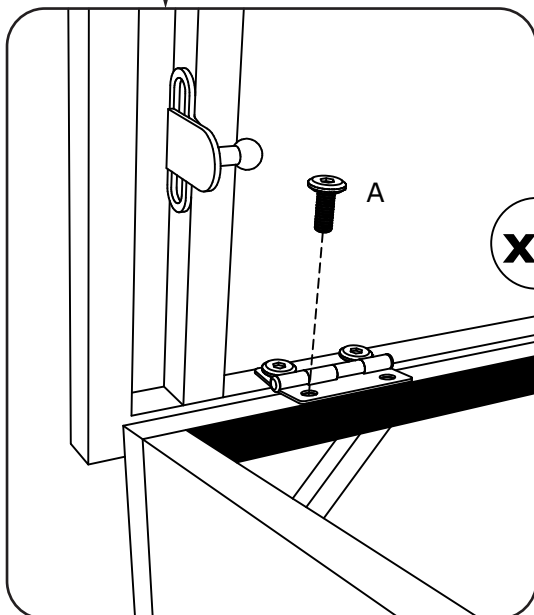
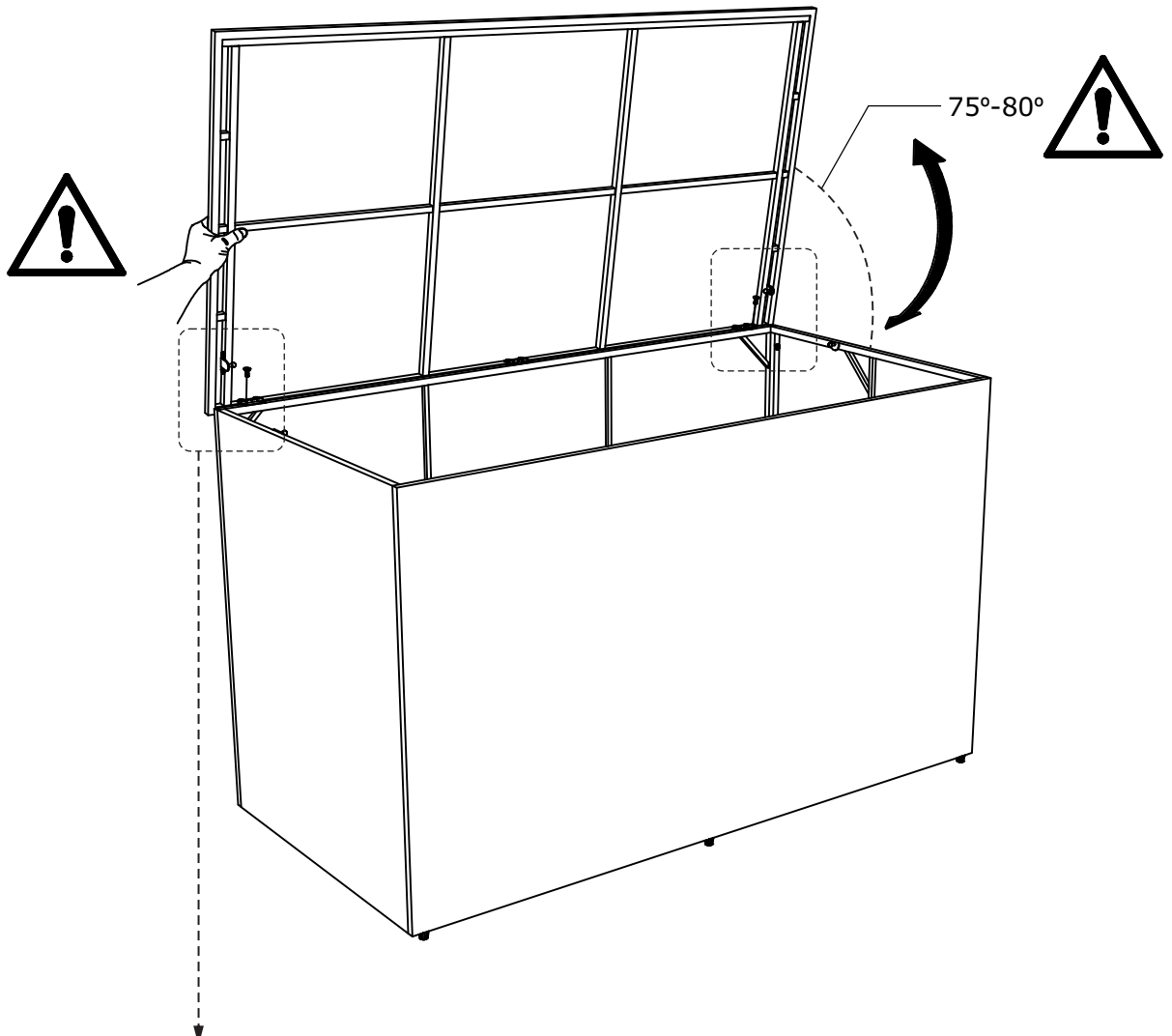

10

A x 4  M6x15 mm	F x 1  4 mm	
--	--	--

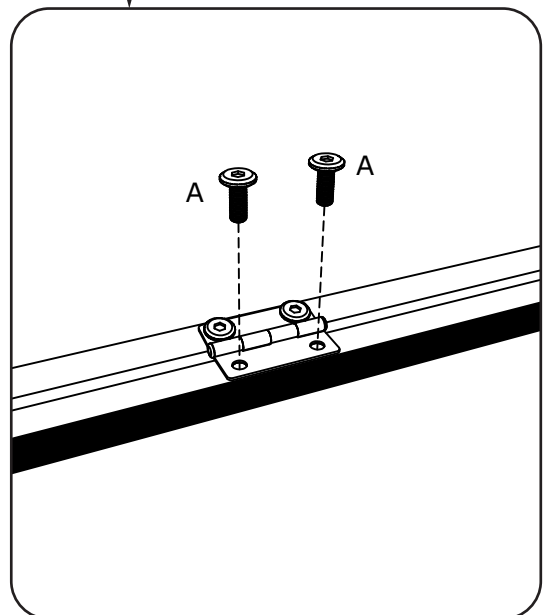
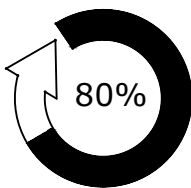
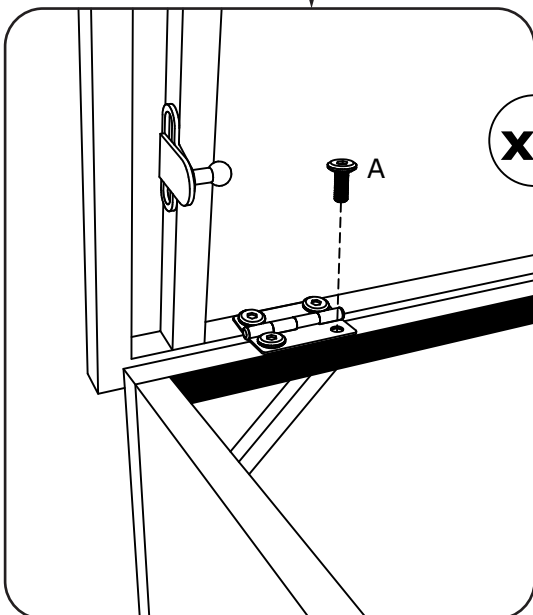
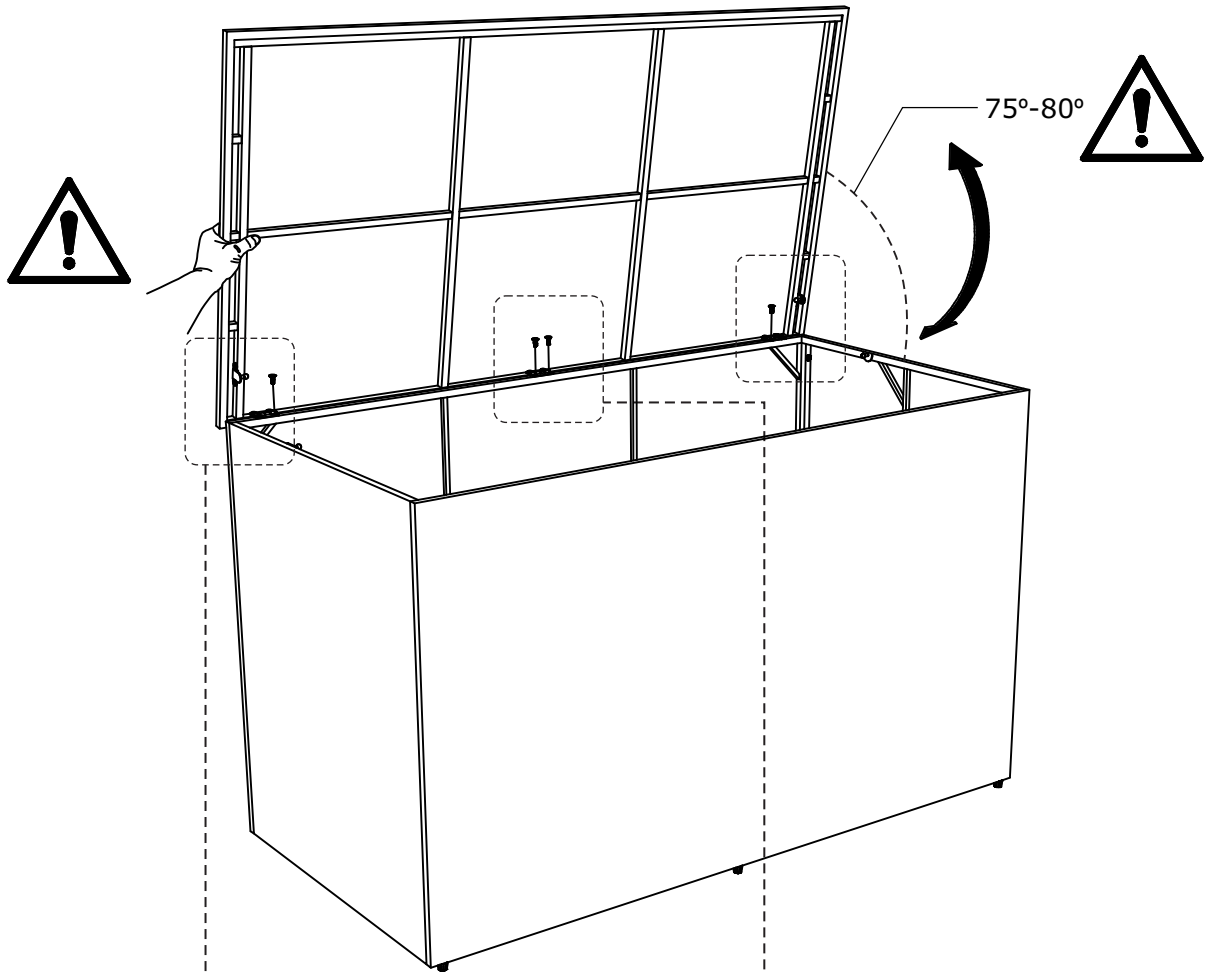

11

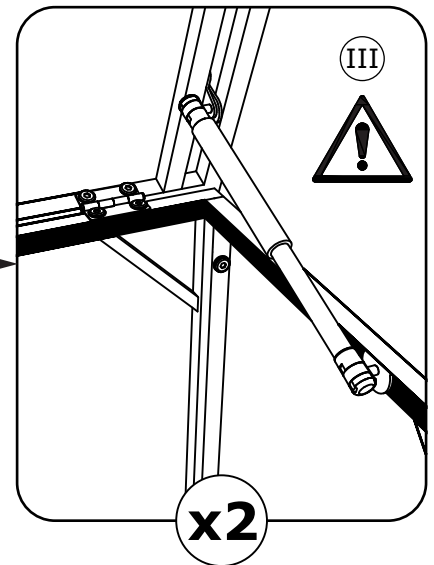
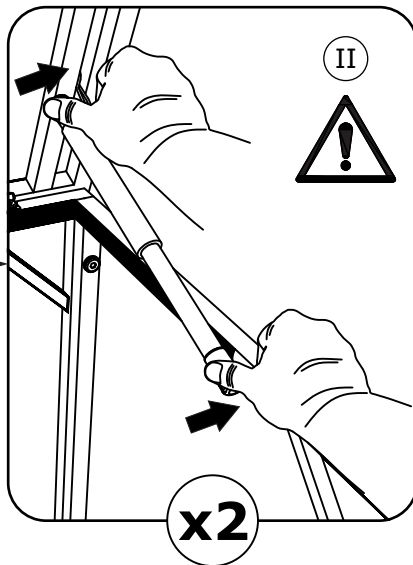
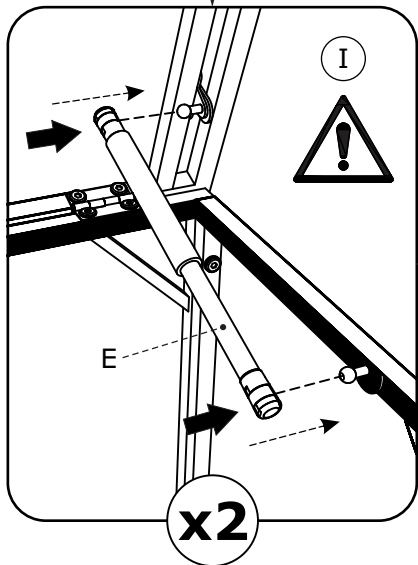
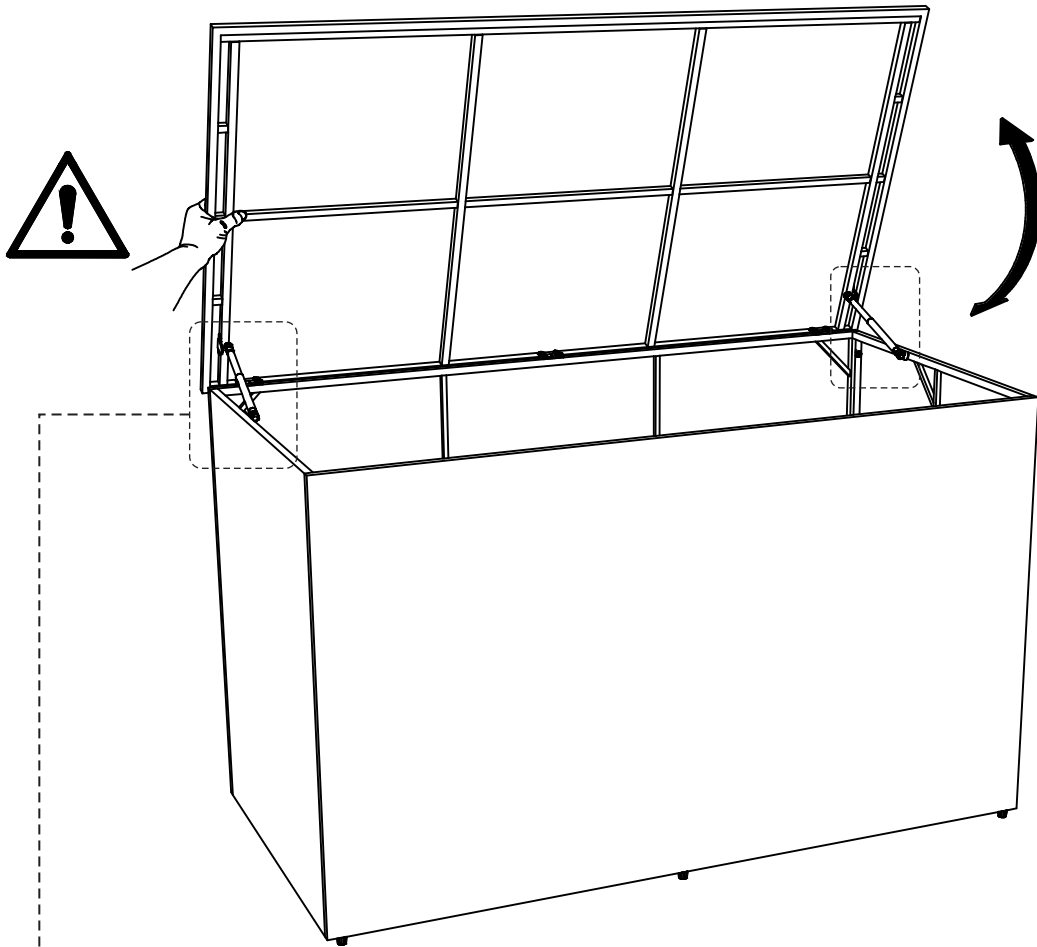

12

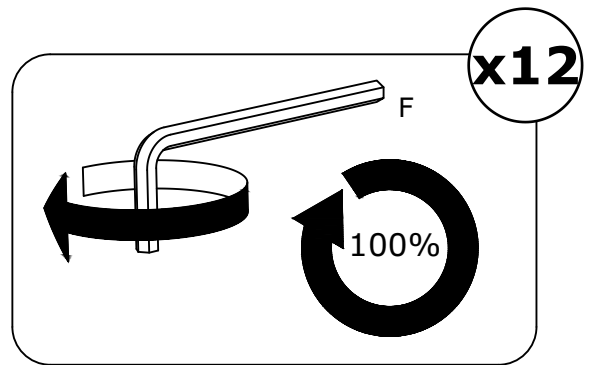
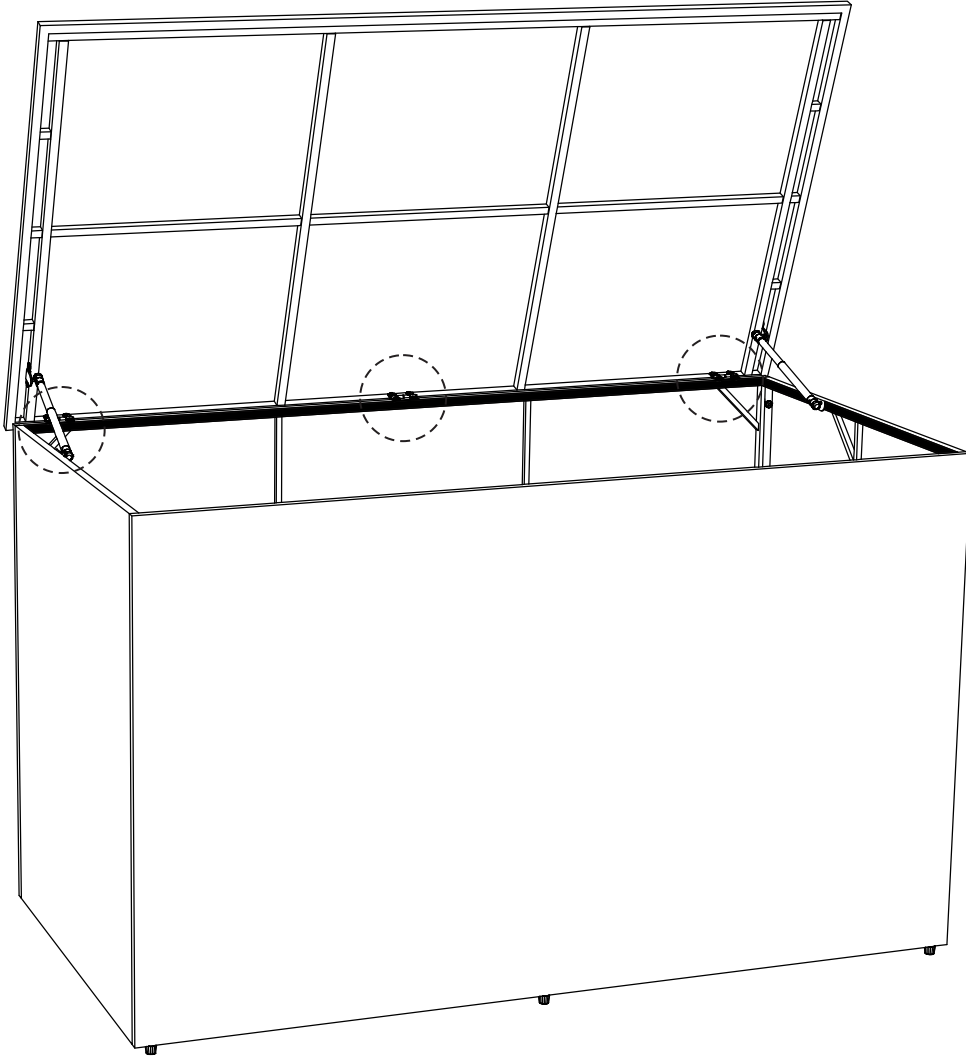
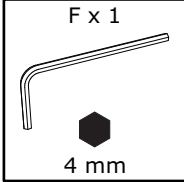

13

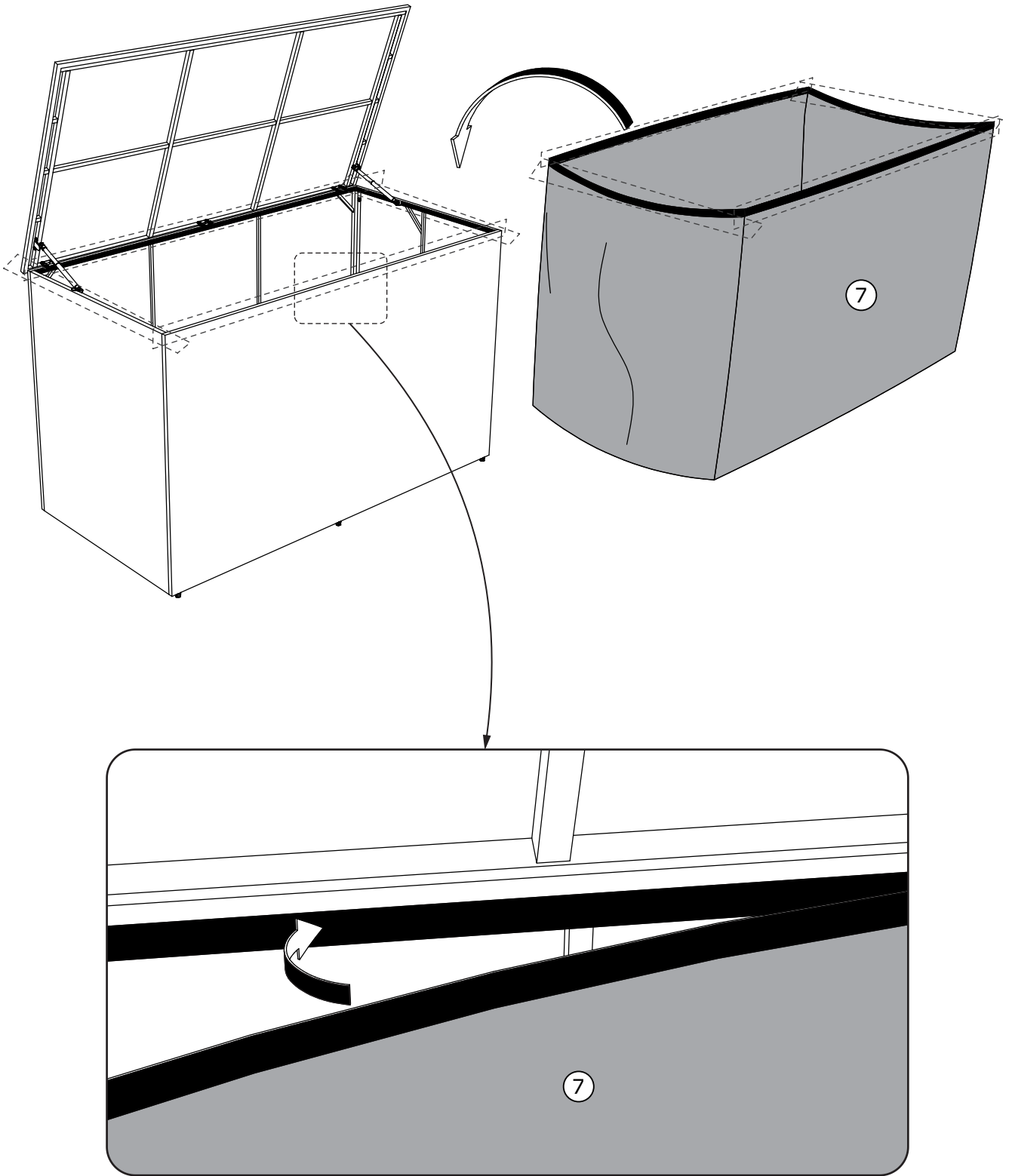

14

