

KONGEMOSE

137080/
913-256-1010
(3726166)

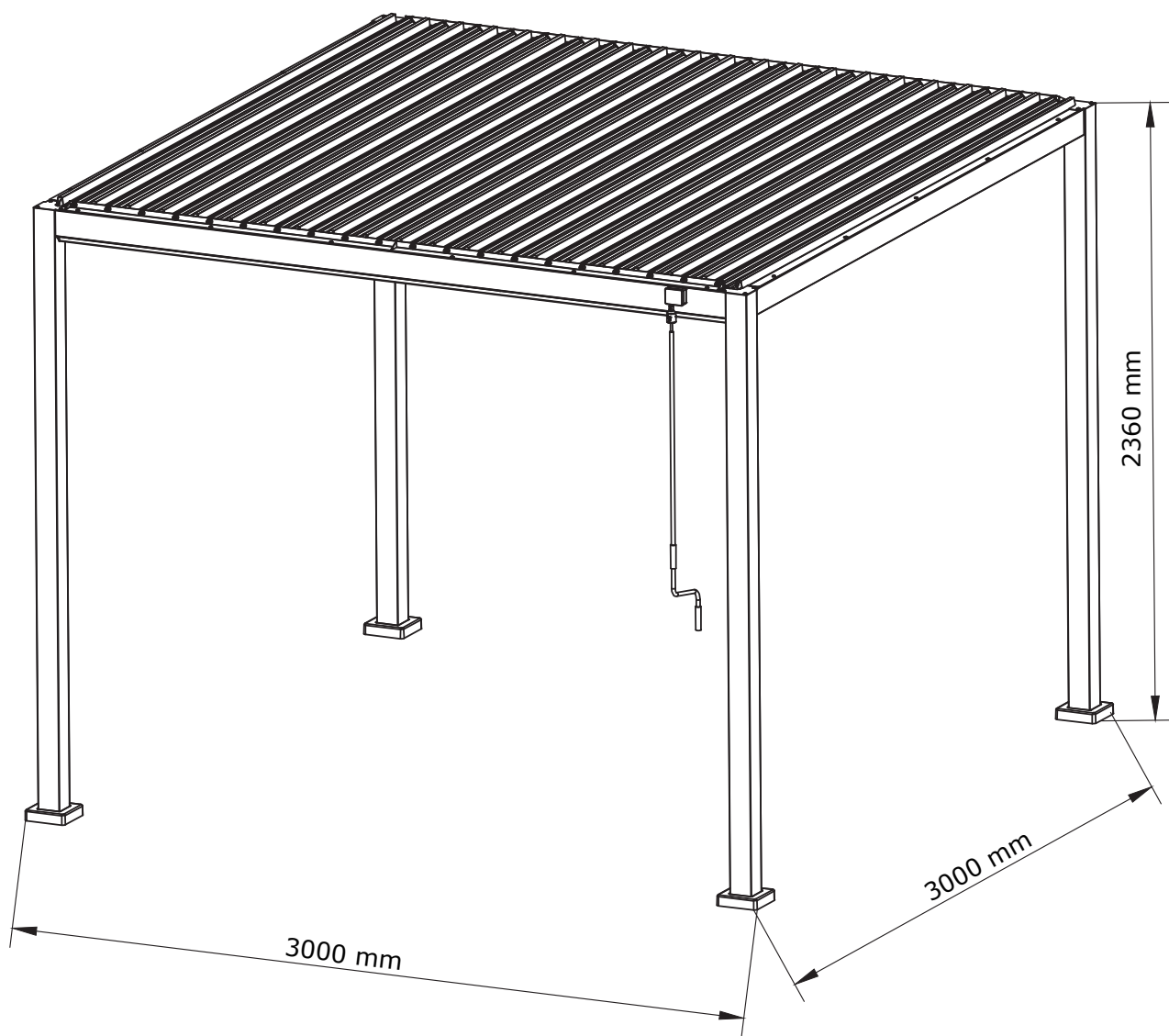

FR
Donnez ou recyclez
vos meubles.



Association

ou



Magasin

ou



Déchèterie

<https://quefairedemesdechets.fr>



JYSK.com

23.03.2026

1/45

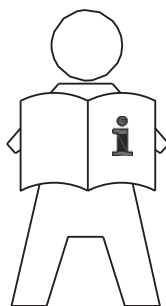

EN: *IMPORTANT INFORMATION!*

Please read the entire manual carefully before starting to assemble and/or using this product. Follow the manual thoroughly and keep it for further reference.

FR: *INFORMATIONS IMPORTANTES*

Veuillez lire attentivement l'ensemble du manuel avant de commencer à monter et/ou utiliser ce produit. Suivez rigoureusement le manuel et conservez-le pour toute consultation ultérieure.

LV: *SVARĪGA INFORMĀCIJA!*

Pirms šī izstrādājuma montāžas un/vai lietošanas uzsākšanas pilnībā izlasiet lietošanas pamācību. Stingri ievērojiet pamācības norādījumus un saglabājiet to turpmākai lietošanai.

LT: *SVARBI INFORMACIJA!*

Prieš pradėdami montuoti gaminį ir (arba) juo naudotis, prašome atidžiai perskaityti visą vadovą. Atidžiai skaitykite vadovą ir turėkite jį su savimi, kad galėtumėte toliau vadovautis jo nuorodomis.

EE: *OLULINE TEAVE!*

Enne kui alustate toote kokku panemist ja/või kasutamist, lugege see kasutusjuhend hoolikalt läbi. Järgige täpselt juhendis toodud juhiseid ja hoidke juhend alles.

RU: *ВАЖНАЯ ИНФОРМАЦИЯ!*

Внимательно и полностью прочитайте это руководство, прежде чем приступать к сборке или использованию этого изделия. Следуйте всем инструкциям этого руководства и сохраните его на будущее для справки.

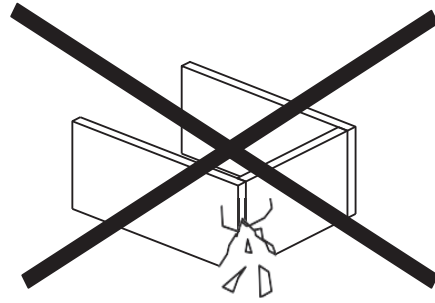
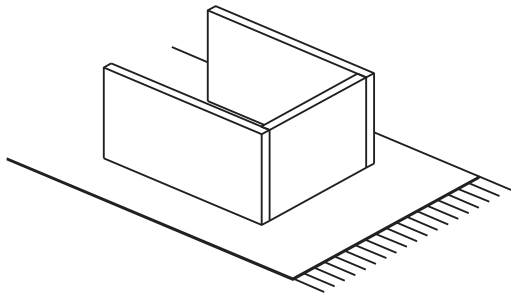

EN: *WARNING TO AVOID SCRATCHES!*

In order to avoid scratching this furniture should be assembled on a soft layer - could be a rug.

FR: *AVERTISSEMENT POUR ÉVITER LES RAYURES*

Afin d'éviter les rayures, ce meuble doit être monté sur une surface souple (un tapis, par exemple).

LV: *BRĪDINĀJUMS PAR SKRĀPĒJUMIEM!*

Lai nesaskrāpētu šo izstrādājumu, veiciet montāžu uz mīkstas pamatnes, piemēram, paklāja.

LT: *ĮSPĖJIMAS, KAD IŠVENGTUMĖTE ĮBRĖŽIMŲ!*

Šio baldo nesubraižysite, jei jį surinksite ant švelnaus paviršiaus, pavyzdžiui, kilimo.

EE: *HOIATUS KRIIMUSTUSTE VÄLTIMISEKS!*

Kriimustuste tekkimise vältimiseks mööblile tuleb see kokku panna pehmel pinnal, nt kaltsuvaibal.

RU: *ПРЕДУПРЕЖДЕНИЕ ОТНОСИТЕЛЬНО ЦАРАПИН!*

Во избежание нанесения царапин, сборку этой мебели необходимо выполнять на мягкой поверхности, например на ковре.



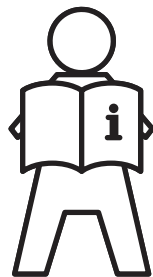

EN: SAFETY WARNING: Important safety instructions. Follow all instructions since incorrect installation can lead to severe injury. Save these instructions.

1. Children shall not play with the appliance. Do not climb on the roof of the gazebo.
2. Keep the gazebo away from open fire. Do not use hot products within your gazebo like barbecue grills.
3. Do not put your head, hands, or any other body part between moving parts like the slats to avoid injuries.
4. Do not use during frosty conditions and temperatures under 3°C! Clear snow from the gazebo in winter.
5. If high winds are expected, fully open the gazebo to reduce wind resistance. In extreme weather, remove and store the slats indoors.
6. Avoid placing or hanging objects on the gazebo. Do not modify the product in any way not intended by the manufacturer. Use only manufacturer-provided replacement parts.
7. Do not lean ladders against the gazebo. Remove any obstacles between moving parts before use.
8. Wear gloves, safety shoes, goggles, and a helmet during assembly. Avoid assembling the gazebo in wind or rain. Keep children and animals away during the installation phase.
9. Retighten the screws two weeks after assembly, and then every three months, to ensure stability.

Foundation:

The product must be placed on a solid and level surface, preferably on concrete or stone slabs. If no suitable surface is available, you will need to create a foundation. Consult a local contractor if necessary. Secure the structure firmly into the ground. If the provided anchor bolts are not suitable for your ground, please purchase appropriate fastening materials for your surface.

FR: AVERTISSEMENT DE SÉCURITÉ: Instructions de sécurité importantes. Suivez toutes les instructions, car une installation incorrecte peut entraîner des blessures graves. Conservez ces instructions.

1. Les enfants ne doivent pas jouer avec l'appareil. Ne montez pas sur le toit du gazebo.
2. Gardez le gazebo éloigné des flammes nues. N'utilisez pas de produits chauds comme des barbecues à l'intérieur du gazebo.
3. Ne placez pas votre tête, vos mains ou toute autre partie du corps entre les parties mobiles comme les lames pour éviter les blessures.
4. Ne pas utiliser en cas de gel ou à des températures inférieures à 3°C ! Dégagez la neige du gazebo en hiver.
5. En cas de vents forts, ouvrez complètement le gazebo pour réduire la résistance au vent. En cas de conditions météorologiques extrêmes, retirez et stockez les lames à l'intérieur.
6. Évitez de placer ou d'accrocher des objets sur le gazebo. Ne modifiez pas le produit de manière non prévue par le fabricant. Utilisez uniquement des pièces de rechange fournies par le fabricant.
7. Ne vous appuyez pas sur des échelles contre le gazebo. Retirez tous les obstacles entre les pièces mobiles avant utilisation.
8. Portez des gants, des chaussures de sécurité, des lunettes et un casque pendant l'assemblage. Évitez d'assembler le gazebo par vent ou pluie. Tenez les enfants et les animaux à l'écart pendant la phase d'installation.
9. Resserrer les vis deux semaines après l'assemblage, puis tous les trois mois, pour garantir la stabilité.
10. Fondation :

Le produit doit être placé sur une surface solide et plane, de préférence sur des dalles de béton ou de pierre. Si aucune surface appropriée n'est disponible, vous devrez créer une fondation. Consultez un entrepreneur local si nécessaire. Fixez solidement la structure au sol. Si les boulons d'ancrage fournis ne conviennent pas à votre sol, achetez des matériaux de fixation adaptés.

LV: BRĪDINĀJUMS PAR DROŠĪBU! Svarīgi norādījumi par drošību. Ievērojiet visas instrukcijas, jo nepareiza uzstādīšana var izraisīt smagu traumu gūšanu. Saglabājiet šo instrukciju.

1. Neļaujiet bērniem spēlēties ar ierīci. Aizliegts kāpt uz nojumes jumt
2. Sargājiet nojumi no atklātas liesmas. Nelietojiet karstus produktus savā nojumē, piemēram, gri restes.
3. Lai izvairītos no traumām, neievietojiet galvu, rokas vai citas ķermeņa daļas starp kustīg detaļām, piemēram, līstēm.
4. Nelietojiet sala apstākļos un, ja temperatūra ir zemāka par 3 °C! Ziemā notīriet sniegu no nojume
5. Ja tiek prognozēts spēcīgs vējš, pilnībā atveriet nojumi, lai samazinātu vēja pretestību. Ekstrēm laikapstākļos noņemiet un uzglabājiet līstes telpās.

6. Nenovietojiet vai nekariniet priekšmetus uz nojumes. Neveiciet nekādas izstrādājuma izmaiņa kuras nav paredzējis ražotājs. Izmantojiet tikai ražotāja nodrošinātās rezerves daļas.
7. Neatstutējiet trepes pret nojumi. Pirms lietošanas noņemiet visus šķēršļus starp kustīgajām daļām
8. Montāžas laikā valkājiet cimdus, drošības apavus, aizsargbrilles un ķiveri. Neveiciet nojum montāžu vējainā vai lietainā laikā. Montāžas laikā neļaujiet tuvumā atrasties bērniem un dzīvniekiem.
9. Divas nedēļas pēc montāžas atkārtoti pievelciet skrūves un pēc tam atkārtojiet to reizi trīs mēnešo lai nodrošinātu stabilitāti.
10. Pama
Izstrādājums jānovieto uz cietas un līdzenas virsmas, vēlams uz betona vai akmens plātnēm. Ja nav pieejama piemērota virsma, jums būs jāizbūvē pamati.
Ja nepieciešams, sazinieties ar kādu vietējo būvnieku. Nostipriniet konstrukciju stingri zemē. Ja komplektā iekļautās enkurskrūves nav piemērotas jūsu gruntij, lūdzu, iegādājieties jūsu virsmai piemērotus stiprinājuma materiālus.

LT: SAUGOS ĪSPĒJIMAI. Svarbīos saugos instrukcijās. Laikykitēs visu instrukciju, nes netinkamas montavimas gali sukelti stiprius sužalojimus. Išsaugokite šias instrukcijas.

1. Vaikams negalima žaisti su gaminiu. Nelipkite ant pavėsinės stog
2. Laikykite pavėsinę atokiau nuo atviros ugnies. Pavėsinėje nenaudokite karštų daiktų, pvz., grilli
3. Kad išvengtumėte sužalojimų, nelaikykite galvos, rankų ar kitų kūno dalių tarp judančių dalių, pvz grotelių.
4. Nenaudokite esant šaltam orui ir temperatūrai žemiau 3 °C! Žiemą nuo pavėsinės nuvalyki sniegą.
5. Jei numatomi stiprūs vėjai, visiškai atidarykite pavėsinę, kad sumažintumėte pasipriešinimą vėju Ekstremaliomis oro sąlygomis nuimkite ir laikykite grotelės patalpoje.
6. Venkite ant pavėsinės statyti ar kabinti daiktus. Nekeiskite gaminio jokiais būdais, kurie nėra numatyti gamintojo. Naudokite tik gamintojo pateiktas atsargines dalis.
7. Į pavėsinę neatremkite kopėčių. Prieš naudojimą pašalinkite visas kliūtis tarp judančių dali
8. Montavimo metu dėvėkite pirštines, apsauginius batus, akinius ir šalną. Venkite montuoti pavėsi esant vėjui ar lietai. Montavimo metu laikykite vaikus ir gyvūnus atokiau.
9. Po surinkimo praėjus dviem savaitėms, o vėliau kas tris mėnesius, vėl priveržkite varžtus, k užtikrintumėte gaminio stabilumą.
10. Pamat
Gaminys turi būti pastatytas ant tvirto ir lygaus paviršiaus, pageidautina ant betono arba akmens plokščių. Jei nėra tinkamo paviršiaus, reikės padaryti pamatus.
Jei reikia pagalbos, kreipkitės į vietos rangovą. Tvirtai pritvirtinkite konstrukciją prie žemės. Jei pateikti tvirtinimo varžtai netinka jūsų pagrindo paviršiui, įsigykite jūsų paviršiui tinkamas tvirtinimo medžiagas.

EE: OHUTUSALANE HOIATUS Olulised ohutusjuhised. Järgige kõiki juhiseid, sest vale paigaldus võib põhjustada raskeid vigastusi. Hoidke juhised alles.

1. Ärge lubage lastel tootega mängida. Ärge ronige varikatuse peal
2. Hoidke varikatus eemal lahtisesest tulest. Ärge kasutage varikatuses all kuumi seadmeid, näiteks grilli
3. Vigastuste vältimiseks ärge pange pead, käsi ega muid kehaosi liikuvate osade (nt lamellribid) vahele.
4. Ärge kasutage varikatust külma ilma korral ega temperatuuril alla 3 °C. Talvel puhastage varikat lumest.
5. Tugeva tuule ootuses avage varikatus täielikult, et vähendada tuuletakistust. Äärmusli ilmastikuolude korral eemaldage lamellribid ja hoiustage neid siseruumides.
6. Vältige esemete asetamist või riputamist varikatusele. Ärge muutke toodet viisil, mida tootja pole ette näinud. Kasutage ainult tootja varuosi.
7. Ärge toetage redelit vastu varikatust. Enne kasutamist eemaldage liikuvate osade vahelt kõ takistused.
8. Kandke varikatuse kokkupaneku ajal kindaid, turvajalatseid, kaitseprille ja kiivrit. Vältige varikatu kokkupanemist tuule või vihmaga. Hoidke lapsed ja loomad paigalduse/kokkupaneku ajal eemal.
9. Stabiilsuse tagamiseks pingutage kruvid uuesti kaks nädalat pärast kokkupanekut ja seejärel i kolme kuu tagant.
10. Aluspi
Toode tuleb paigaldada tugevale ja tasasele pinnale, eelistatavalt betoonile või kiviplaatile. Kui sobivat pinda pole, tuleb rajada vundament.
Vajaduse korral konsulteerige kohaliku ehitusspetsialistiga. Kinnitage konstruktsioon kindlalt maapinna külge. Kui kaasasolevad ankurpoldid ei sobi pinnasega, soetage sobivad kinnitvahendid.

RU: ПРЕДУПРЕЖДЕНИЕ О БЕЗОПАСНОСТИ: Важные инструкции по безопасности. Следуйте всем инструкциям, так как неправильная установка может привести к серьезным травмам. Сохраните эти инструкции.

1. Дети не должны играть с устройством. Не поднимайтесь на крышу беседки.
2. Держите беседку подальше от открытого огня. Не используйте горячие предметы, такие как грили для барбекю, внутри беседки.
3. Не кладите голову, руки или другие части тела между движущимися частями, такими как ламели, чтобы избежать травм.
4. Не используйте беседку при морозных условиях и при температуре ниже 3°C! Очищайте снег с беседки зимой.
5. Если ожидаются сильные ветры, полностью откройте беседку, чтобы уменьшить сопротивление ветру. В экстремальных погодных условиях снимите ламели и храните их в помещении.
6. Избегайте размещения или подвешивания предметов на беседку. Не модифицируйте изделие каким-либо образом, не предусмотренным производителем. Используйте только запасные части, предоставленные производителем.
7. Не прислоняйте лестницы к беседке. Уберите все препятствия между движущимися частями перед использованием.
8. Во время сборки надевайте перчатки, защитную обувь, очки и шлем. Избегайте сборки беседки при ветре или дожде. Держите детей и животных подальше во время установки.
9. Через две недели после сборки подтяните винты, а затем каждые три месяца, чтобы обеспечить стабильность.
10. **Фундамент:**
Изделие должно быть установлено на твердую и ровную поверхность, желательно на бетонные или каменные плиты. Если подходящая поверхность недоступна, необходимо создать фундамент. При необходимости проконсультируйтесь с местным подрядчиком. Надежно закрепите конструкцию на земле. Если предоставленные анкерные болты не подходят для вашей поверхности, приобретите соответствующие крепежные материалы для вашей поверхности.

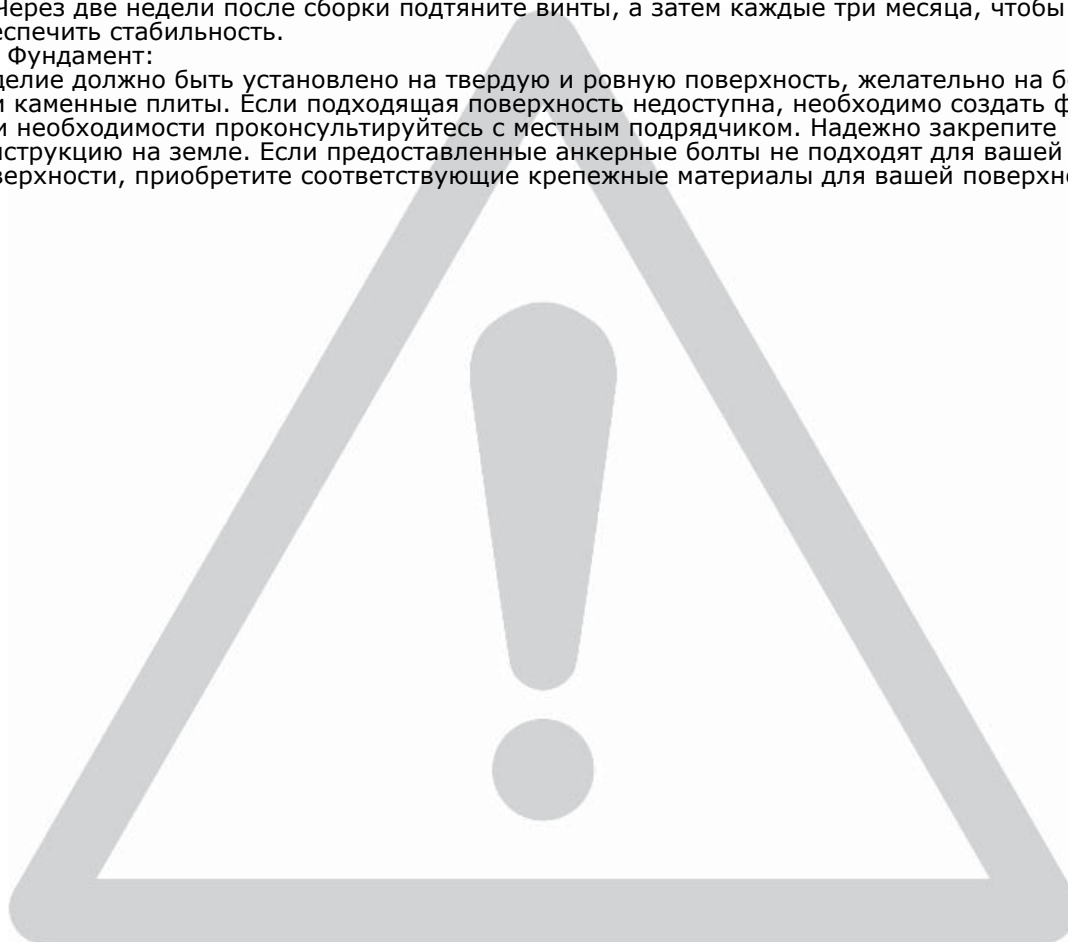

EN: AVOID RUST DURING ASSEMBLY

- This product uses 304 stainless steel screws.
- DO NOT use magnetic or rusty screwdrivers, as this may transfer particles that can cause rust.
- We recommend using a non-magnetic and stainless steel-compatible tool for best results.
- Always clean screws before installation to remove any debris or contamination.

CARE & MAINTENANCE

- To ensure smooth operation and prolong the life of your pergola:
- Clean the gazebo slats regularly to prevent buildup that may hinder function or cause damage.
- Apply silicone oil to the louver mechanism periodically to maintain smooth motion and durability.

FR: ÉVITEZ LA ROUILLE PENDANT L'ASSEMBLAGE

- Ce produit utilise des vis en acier inoxydable 304.
- N'UTILISEZ PAS de tournevis magnétiques ou rouillés, car ils peuvent transférer des particules susceptibles de provoquer la rouille.
- Nous recommandons d'utiliser un outil non magnétique compatible avec l'acier inoxydable pour de meilleurs résultats.
- Nettoyez toujours les vis avant l'installation pour éliminer toute saleté ou contamination.

ENTRETIEN & MAINTENANCE

- Pour assurer un fonctionnement fluide et prolonger la durée de vie de votre pergola :
- Nettoyez régulièrement les lames de la tonnelle pour éviter tout dépôt susceptible de gêner le fonctionnement ou d'endommager.
- Appliquez périodiquement de l'huile silicone sur le mécanisme des lames pour maintenir un mouvement fluide et une durabilité optimales.

LV: IZVAIRIETIES NO RŪSAS MONTĀŽAS LAIKĀ

- *Sajā izstrādājumā izmantotas 304 nerūsējošā tērauda skrūves.*
- *NEKĀDA GADĪJUMA nelietojiet magnētiskus vai sarūsējušus skrūvgriežus, jo tie var pārnest daļiņas, kas var izraisīt rūsēšanu.*
- *Lai iegūtu vislabākos rezultātus, ieteicams lietot nemagnētisku un nerūsējošā tērauda instrumentu.*
- *Pirms uzstādīšanas vienmēr notīriet skrūves, lai noņemtu jebkādas netīrumus vai piesārņojumu.*

KOPSĀNA

- *Lai nodrošinātu nojumes lietošanu bez problēmām un pagarinātu tās ekspluatācijas laiku:*
- *Regulāri notīriet nojumes listes, lai novērstu netīrumu uzkrāšanos, kas var traucēt lietošanai vai izraisīt bojājumus.*
- *Periodiski uzklājiet silikona eļļu uz žālūziju mehānisma, lai saglabātu vienmērīgu kustību un izturību.*

LT: VENKITE RŪDŽIŲ SUSIDARYMO SURINKIMO METU

- *Siame gaminyje naudojami 304 nerūdijančio plieno varžtai.*
- *NENAUDOKITE magnetinių ar surūdijusių atsuktuvų, nes jie gali perkelti daleles, galinčias sukelti rūdijimą.*
- *Norėdami pasiekti geriausių rezultatų naudokite nemagnetinius ir nerūdijančio plieno įrankius.*
- *Prieš montavimą visada nuvalykite varžtus, kad pašalintumėte bet kokius nešvarumus ar užteršimus.*

VALYMAS IR TECHNINĖ PRIEŽIŪRA

- *Kad pavėsinė būtų funkcionali ir tarnautų ilgiau:*
- *Reguliariai valykite pavėsinės groteles, kad nesikauptų nešvarumai, nes dėl jų pavėsinė gali blogai funkcionuoti arba būti sugadinta.*
- *Reguliariai tepkite silikono aliejumi žaliuzių mechanizmą, kad jis gerai veiktų ir ilgai tarnautų.*

EE: ROOSTETAMISE ENNETAMINE KOKKUPANEKU AJAL

- *Selles tootes kasutatakse 304 roostevabast terasest kruvi.*
- *ÄRGE kasutage magnetilisi ega roostes kruvikeerajaid, kuna need võivad edasi kanda osakesi, mis põhjustavad roostet.*
- *Parima tulemuse saamiseks soovitame kasutada mittemagnetilisi ja roostevaba terasega kasutamiseks mõeldud tööriistu.*
- *Võimaliku mustuse või saaste eemaldamiseks puhastage kruvid alati enne paigaldamist.*

HOOLDUS

- *Et tagada varikatuse sujuv kasutamine ja pikk kasutusiga:*
- *Puhastage lamellkatuse osi regulaarselt, et vältida mustuse kogunemist, mis võib takistada funktsioneerimist või põhjustada kahjustusi.*
- *Määrige lamellkatuse mehhanismi regulaarselt silikoonõliga, et säilitada selle sujuv liikumine ja vastupidavus.*

RU: ИЗБЕГАЙТЕ РЖАВЧИНЫ ПРИ СБОРКЕ

- Этот продукт использует винты из нержавеющей стали 304.
- НЕ используйте магнитные или ржавые отвертки, так как они могут переносить частицы, вызывающие ржавчину.
- Рекомендуется использовать немагнитный инструмент, совместимый с нержавеющей сталью, для наилучшего результата.
- Всегда очищайте винты перед установкой, чтобы удалить загрязнения или загрязняющие вещества.

УХОД И ОБСЛУЖИВАНИЕ

- Чтобы обеспечить плавную работу и продлить срок службы перголы:
- Регулярно очищайте ламели беседки, чтобы предотвратить накопления, которые могут препятствовать работе или повредить механизм.
- Периодически наносите силиконовое масло на механизм ламелей, чтобы поддерживать плавное движение и долговечность.

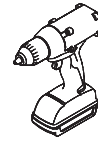

A x 12



M6 x 10 mm

B x 96

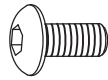

M6 x 12 mm

C x 36

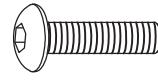

M6 x 20 mm

D x 8

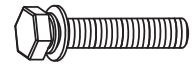

M8 x 25 mm

E x 1



M5 x 20 mm

F x 42



Ø12 x 23 mm

G x 50



Ø12.7/Ø17 mm

H x 8



M6 x 60 mm

J x 1



Ø10 x 160 mm

K x 2

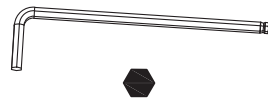

4 mm

L x 2

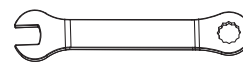

10 mm

M x 2



13 mm

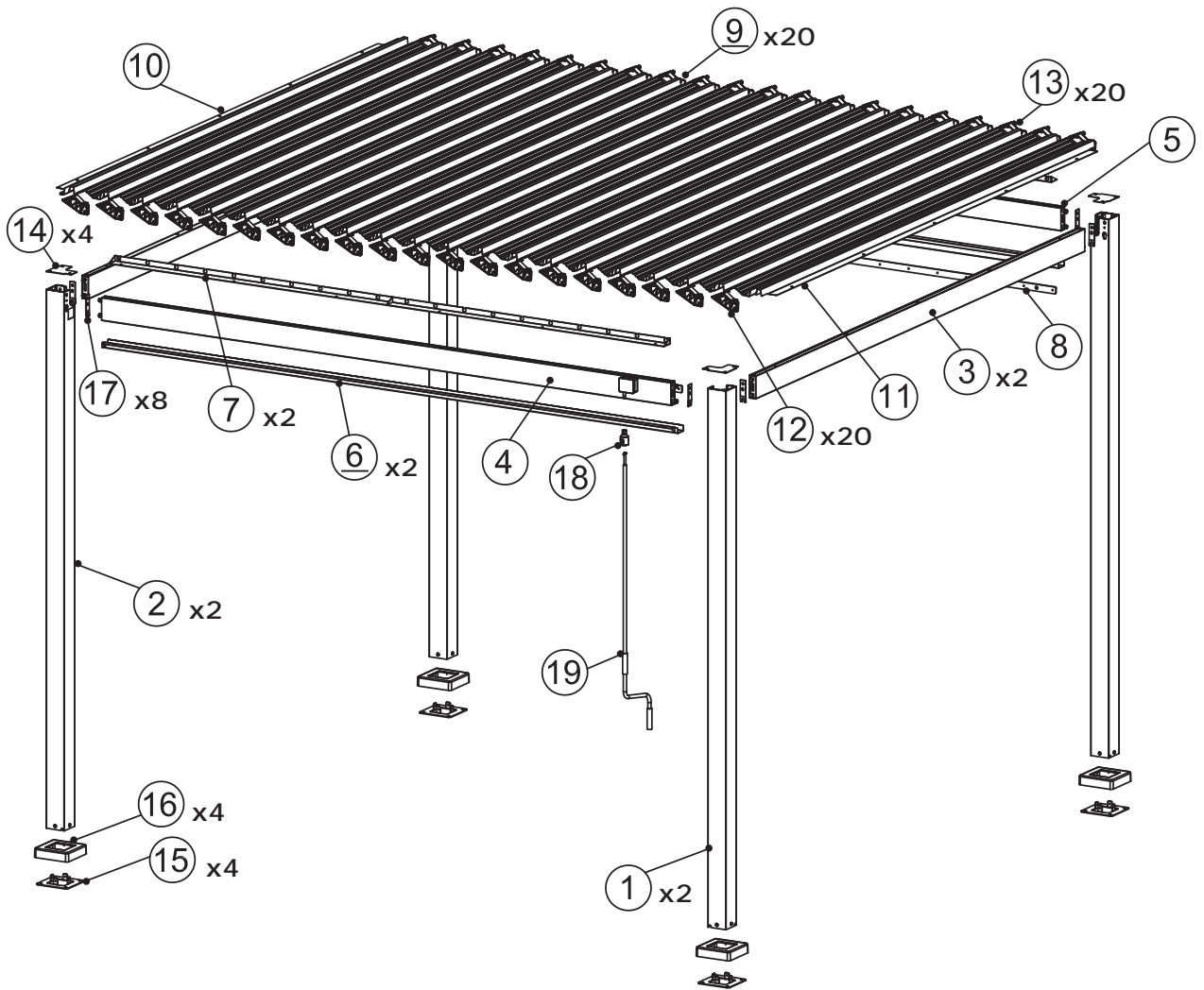

Box 1/5 :

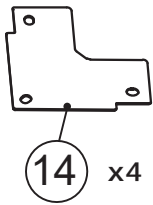
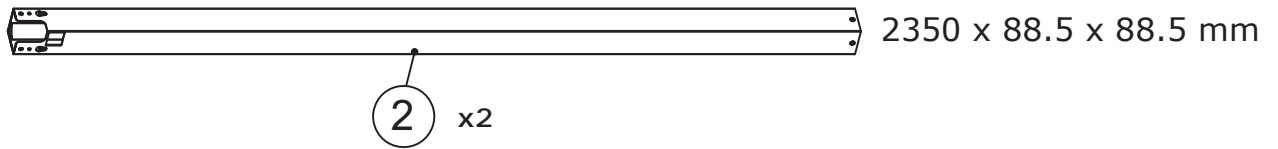
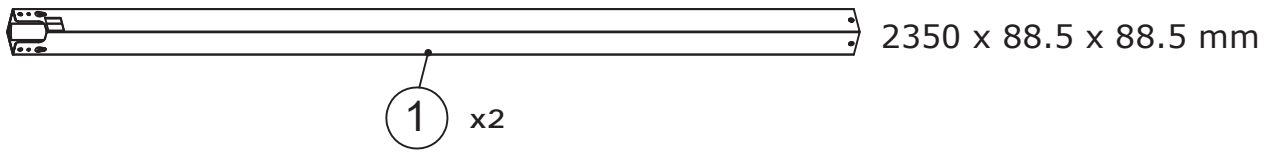

118 x 118 x 1.5 mm



60 x Ø33 mm

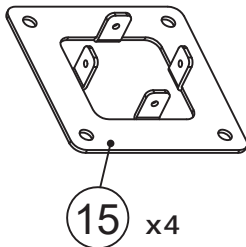

152 x 152 x 30 mm

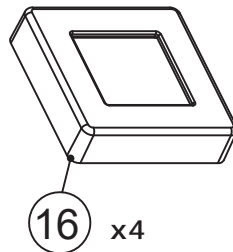

165 x 165 x 40 mm

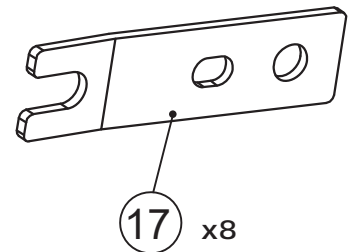

95 x 25 x 3 mm

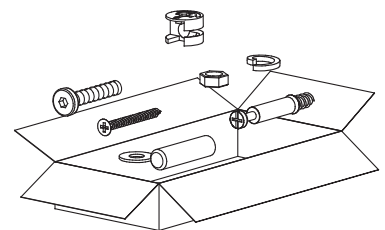

Box 2/5 :

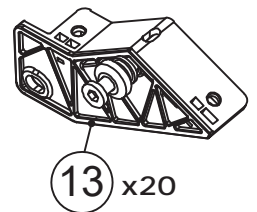
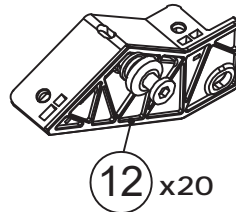
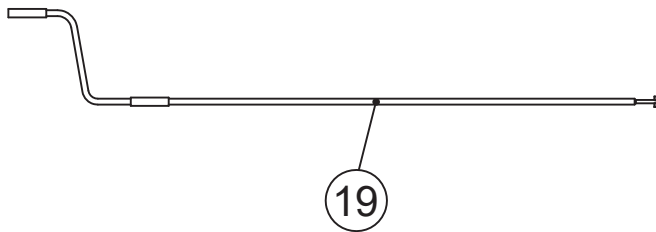
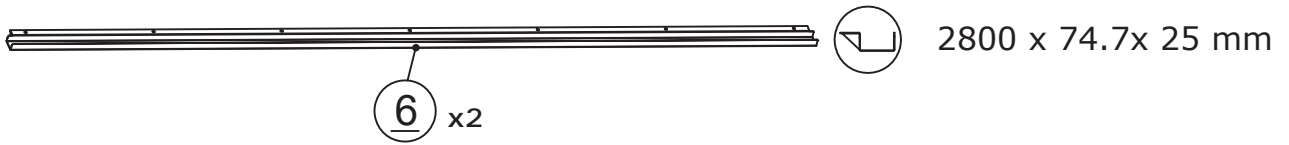
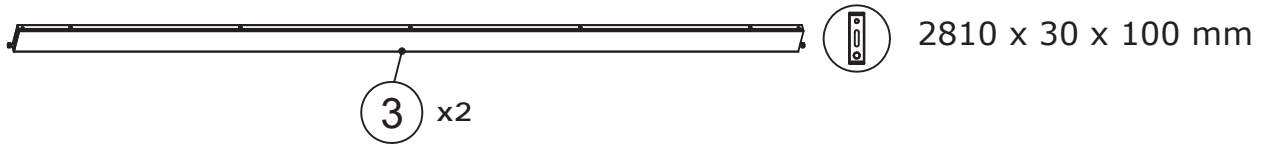

Box 3/5 :

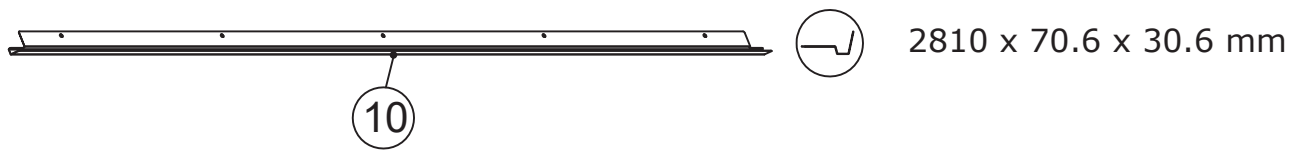
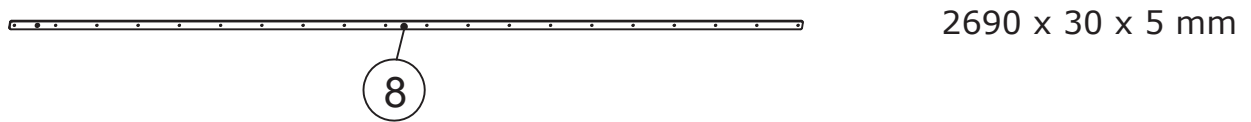
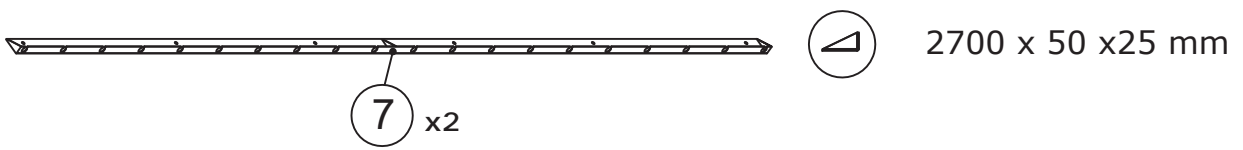
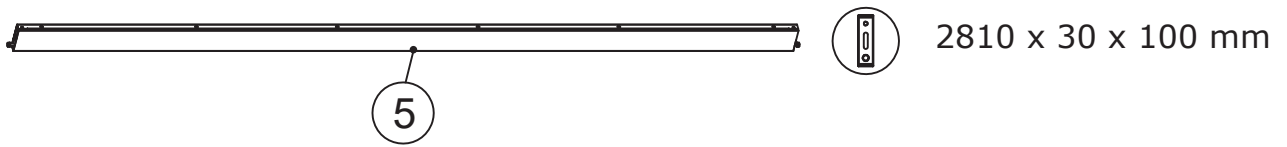
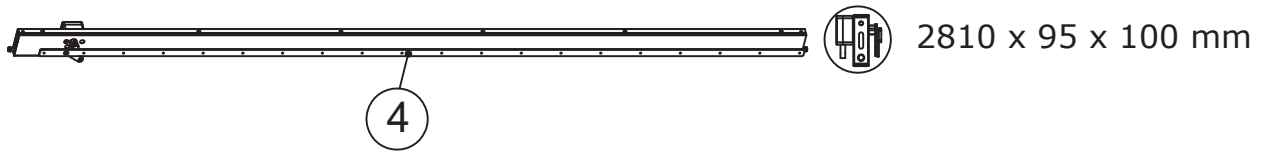

Box 4/5 :



Box 5/5 :

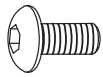

1

B x 16

M6 x 12 mm

K x 2

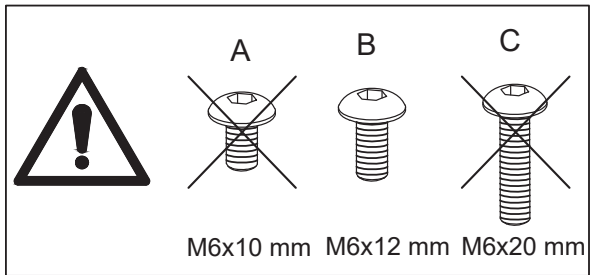
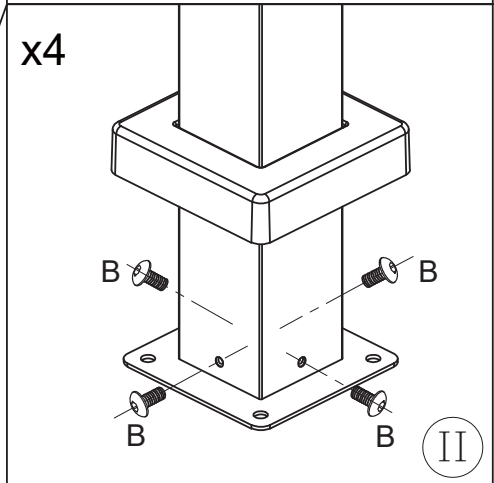
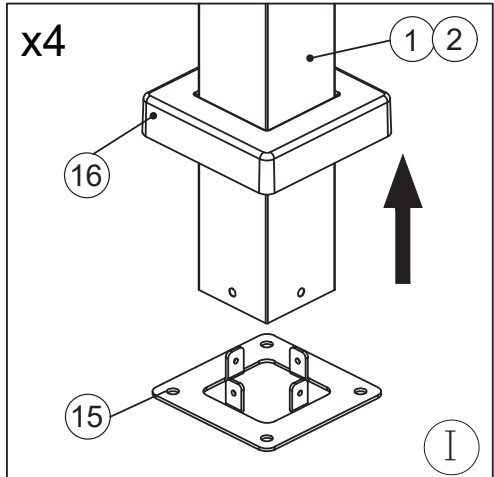
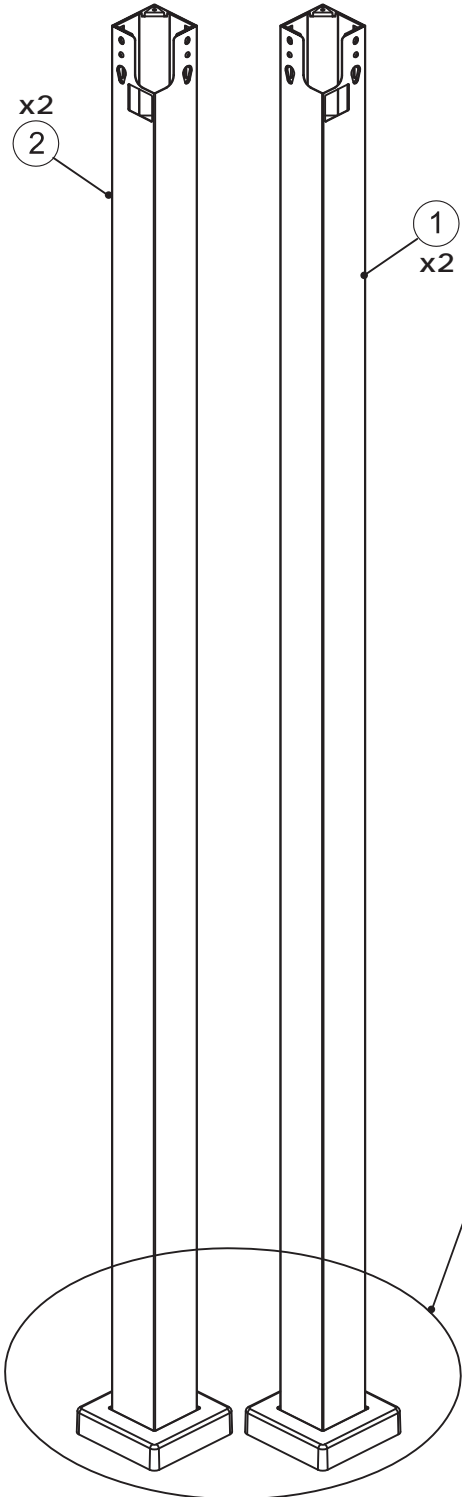
4 mm



2

C x 6
M6 x 20 mm

K x 2
4 mm

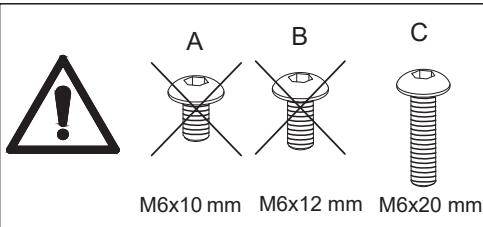
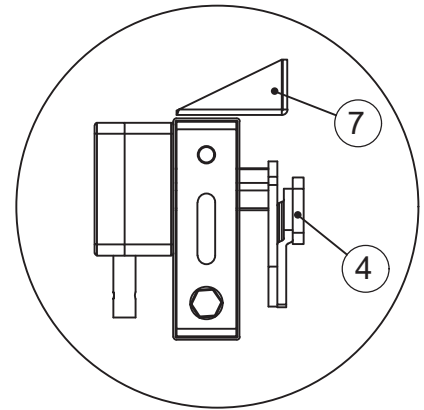
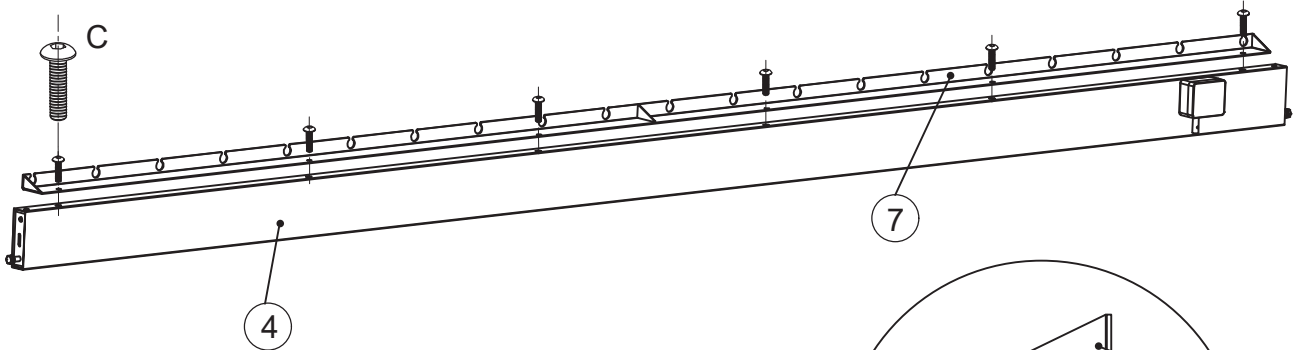

3

C x 7
M6 x 20 mm

K x 2
4 mm

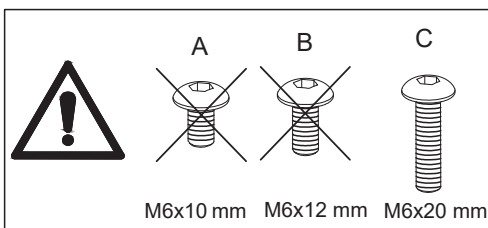
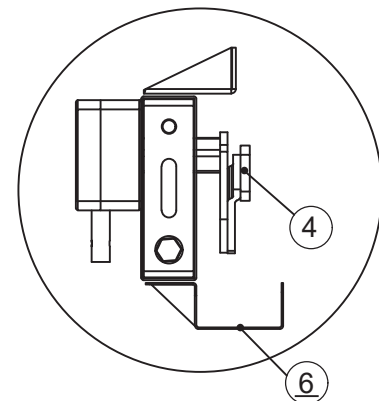
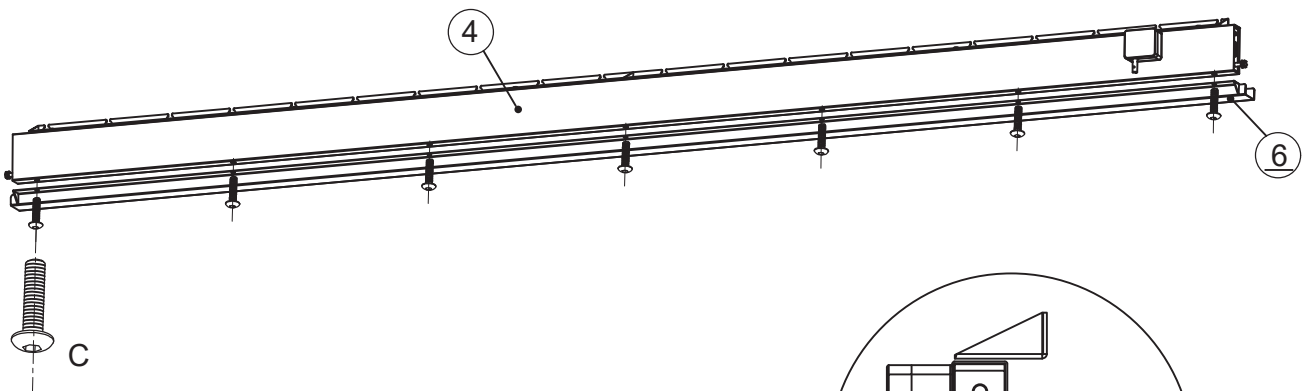

4

C x 6
M6 x 20 mm

K x 2
4 mm

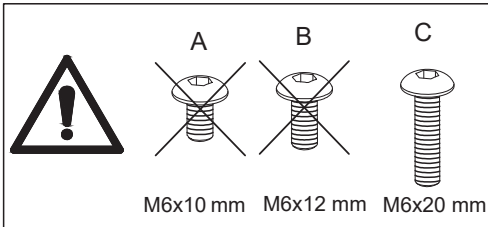
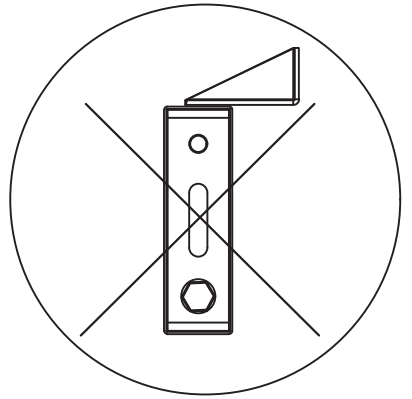
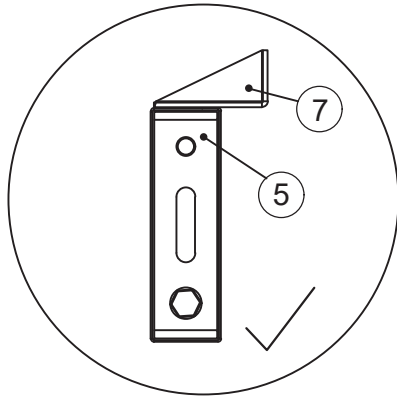
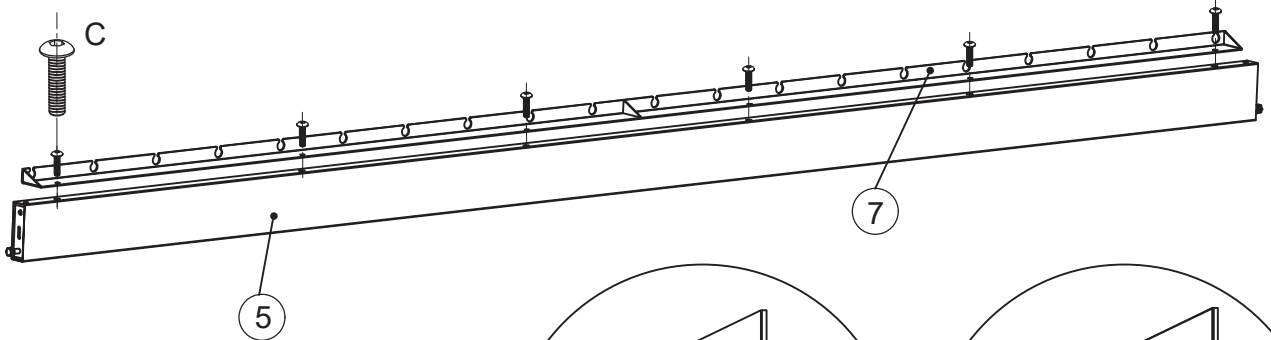

5

C x 7
M6 x 20 mm

K x 2
4 mm

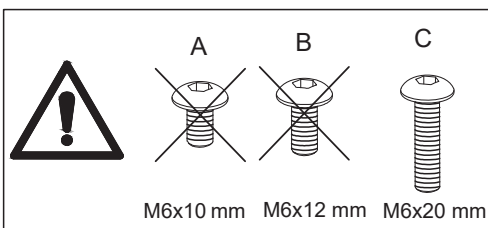
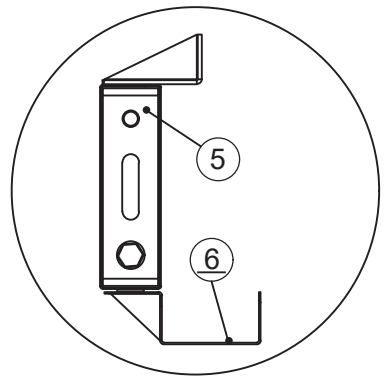
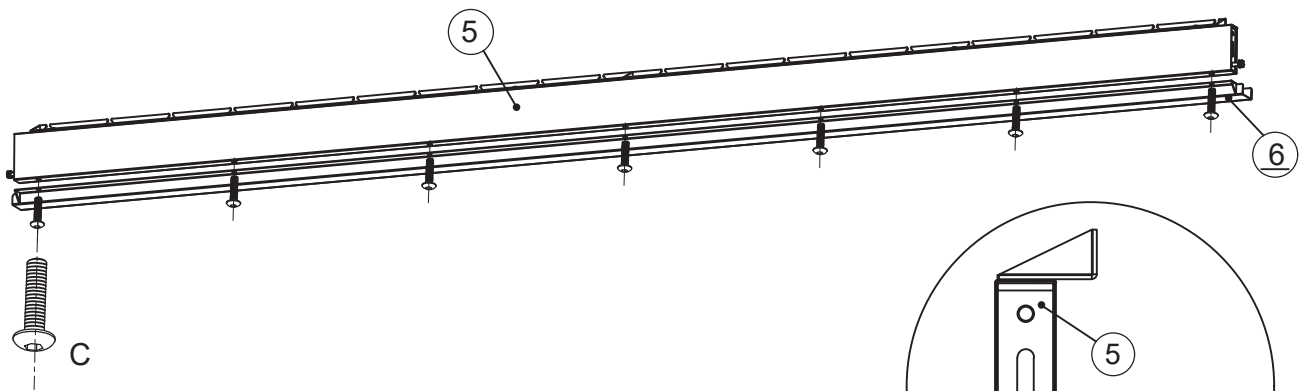

6

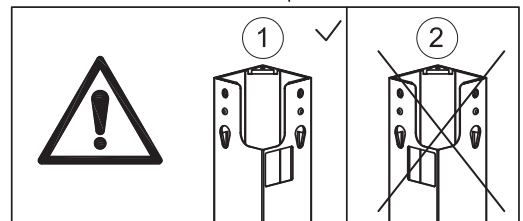
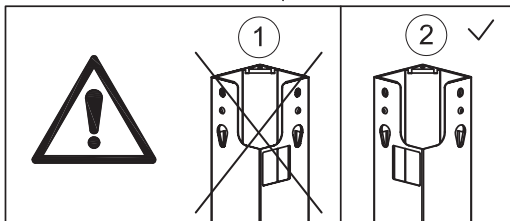
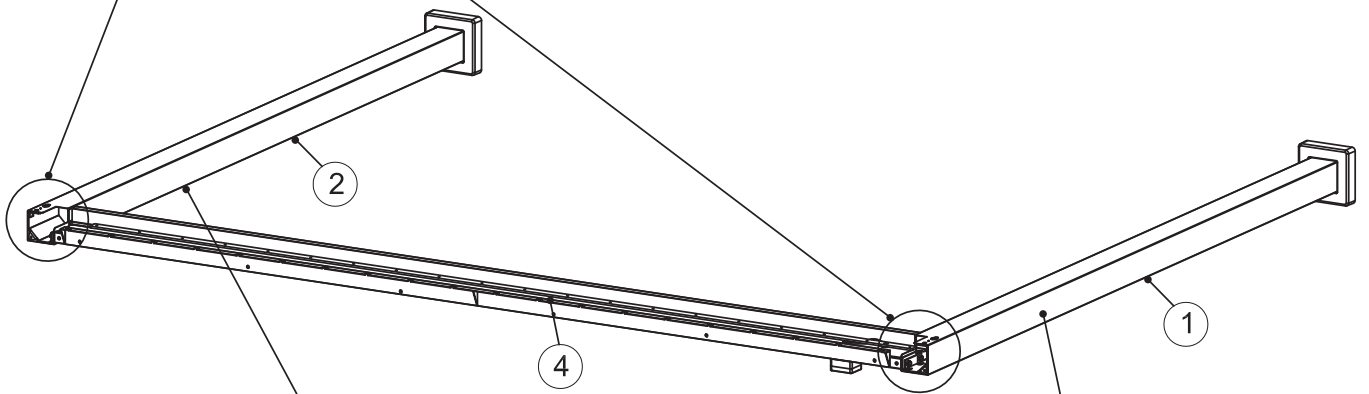
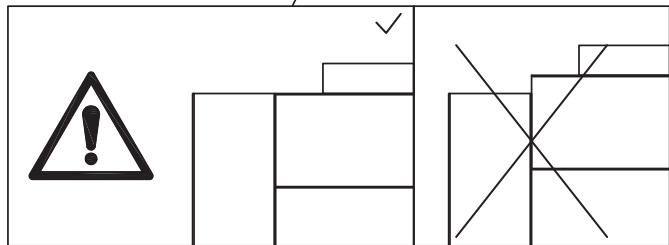
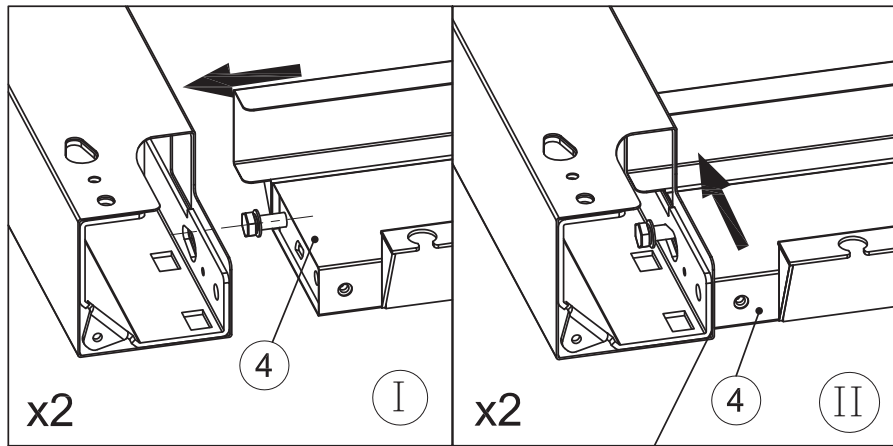

7

D x 2  M8 x 25 mm	M x 2  13 mm	
--	---	--

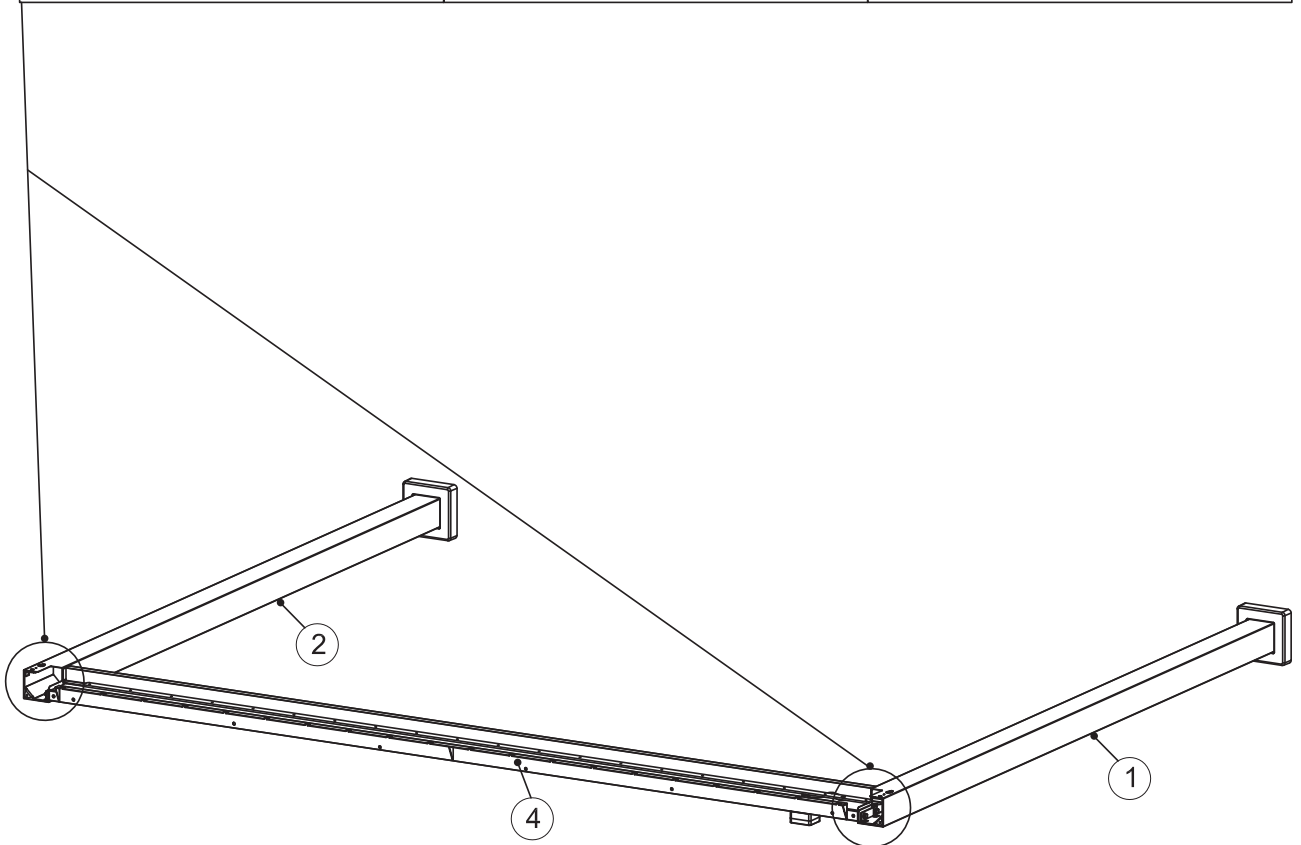
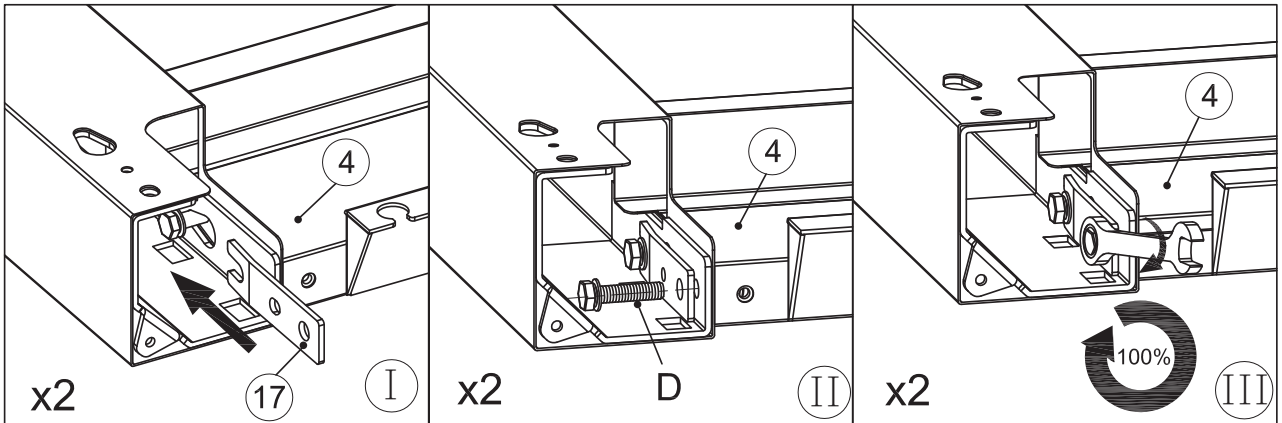

8

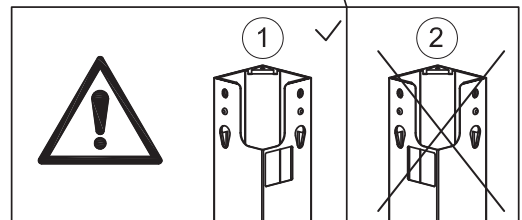
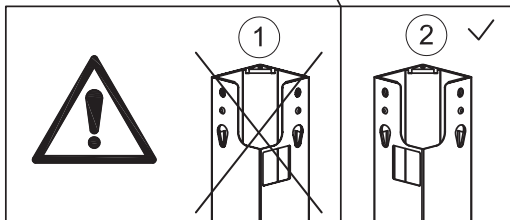
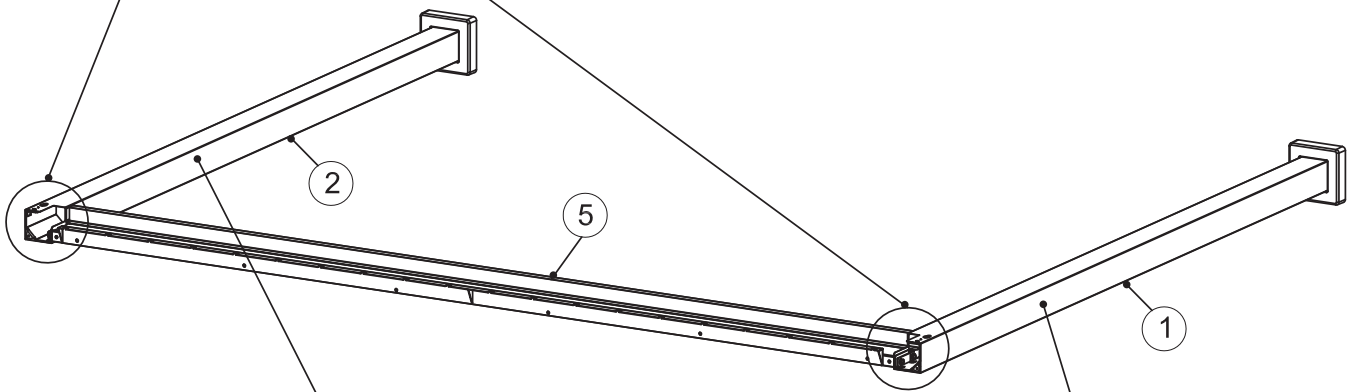
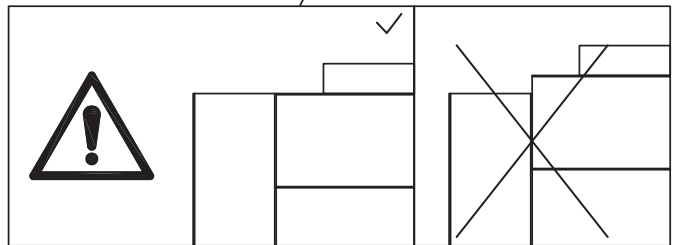
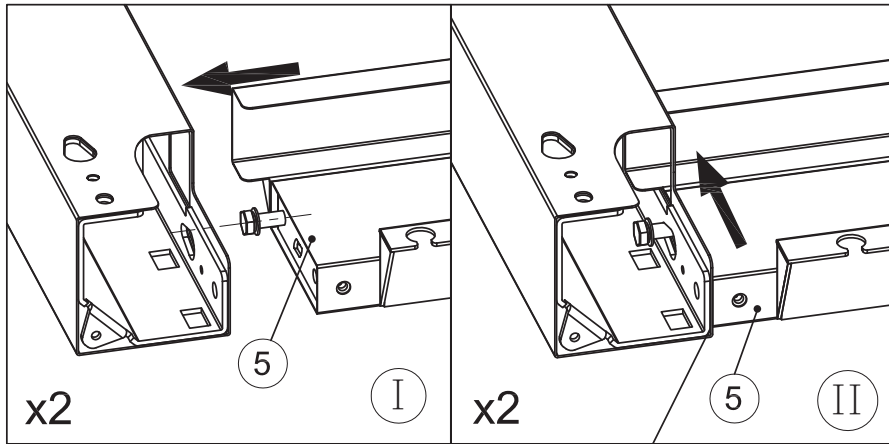

9

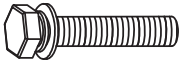

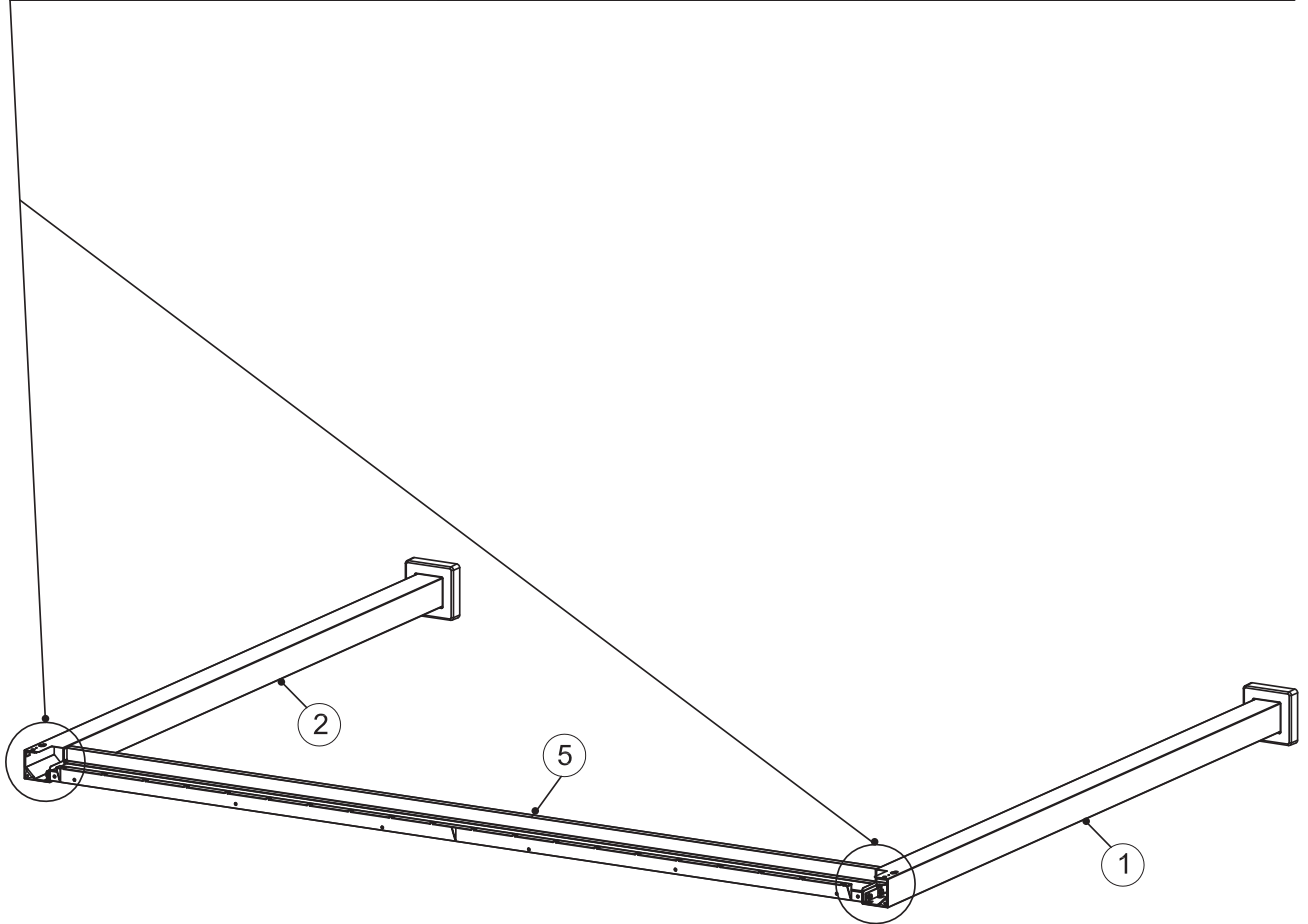
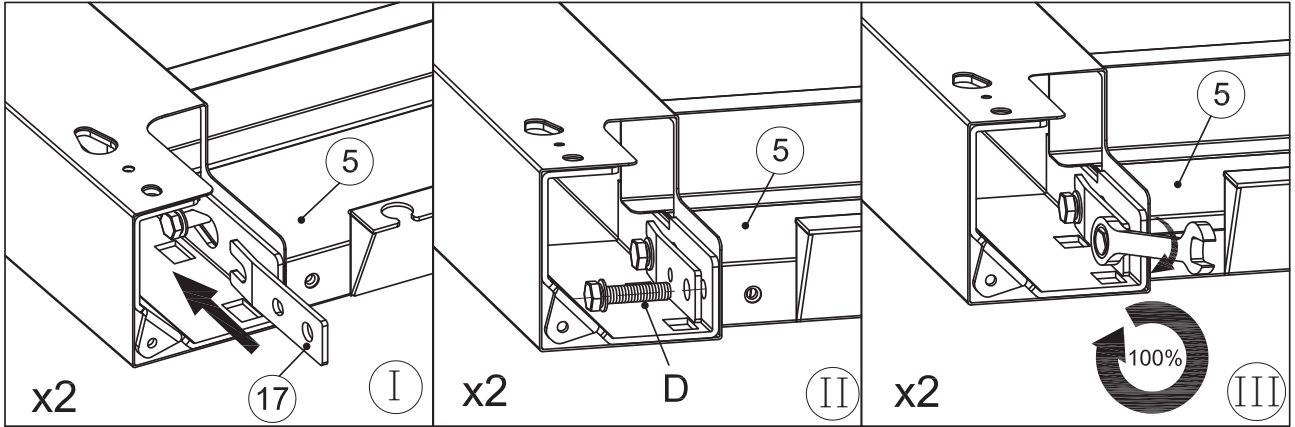
<p>D x 2</p>  <p>M8 x 25 mm</p>	<p>M x 2</p>  <p>13 mm</p>	
--	---	--

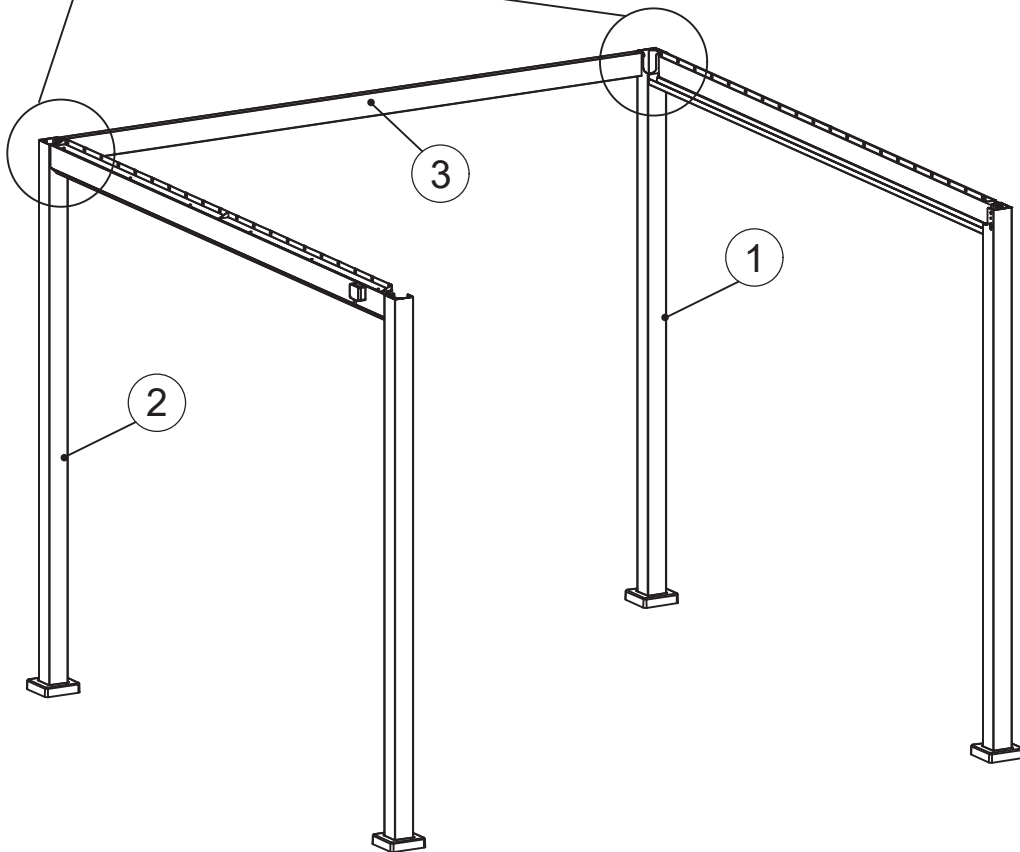
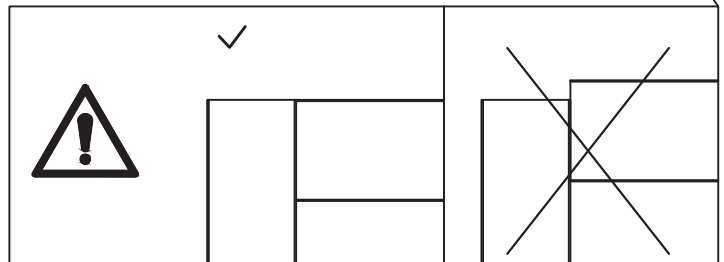
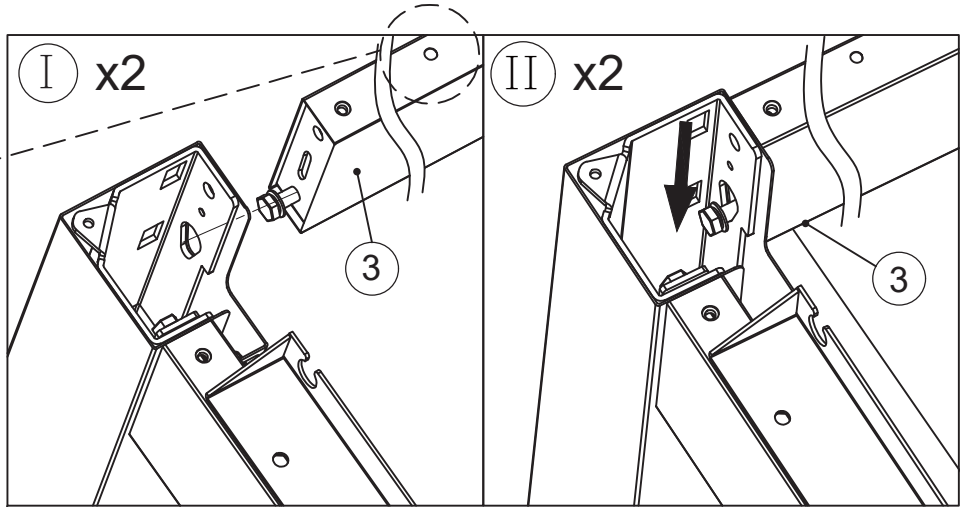
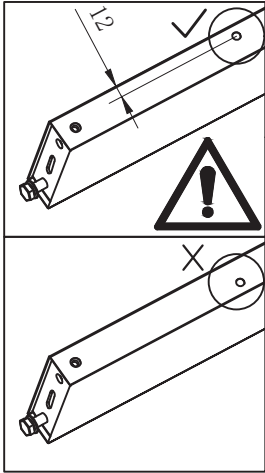
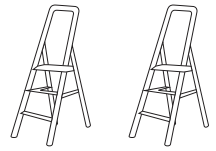

10

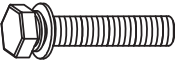

11

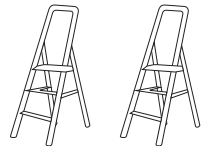

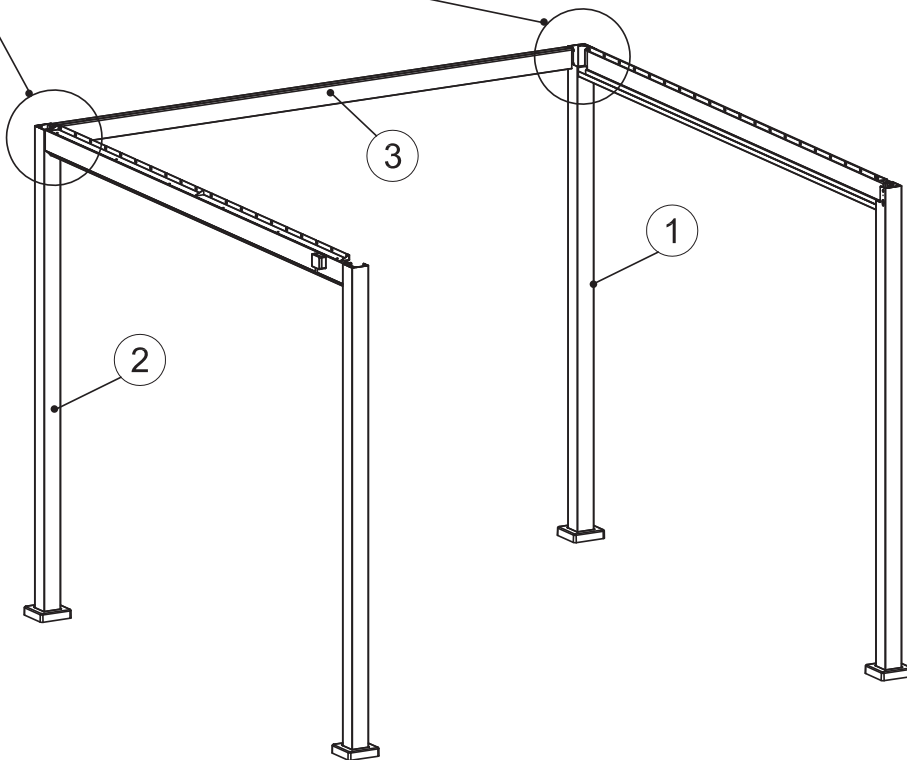
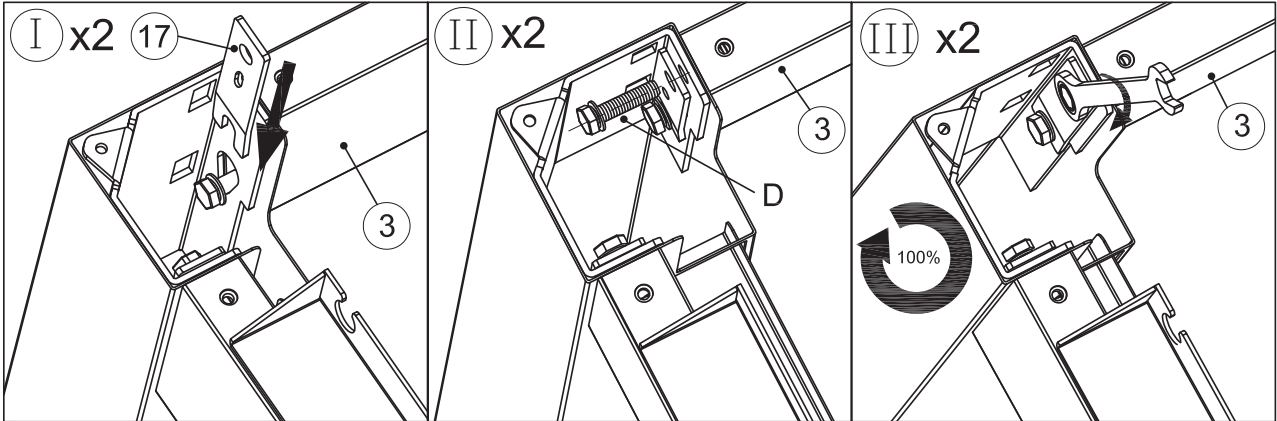
D x 2  M8 x 25 mm	M x 2  13 mm	
--	---	---

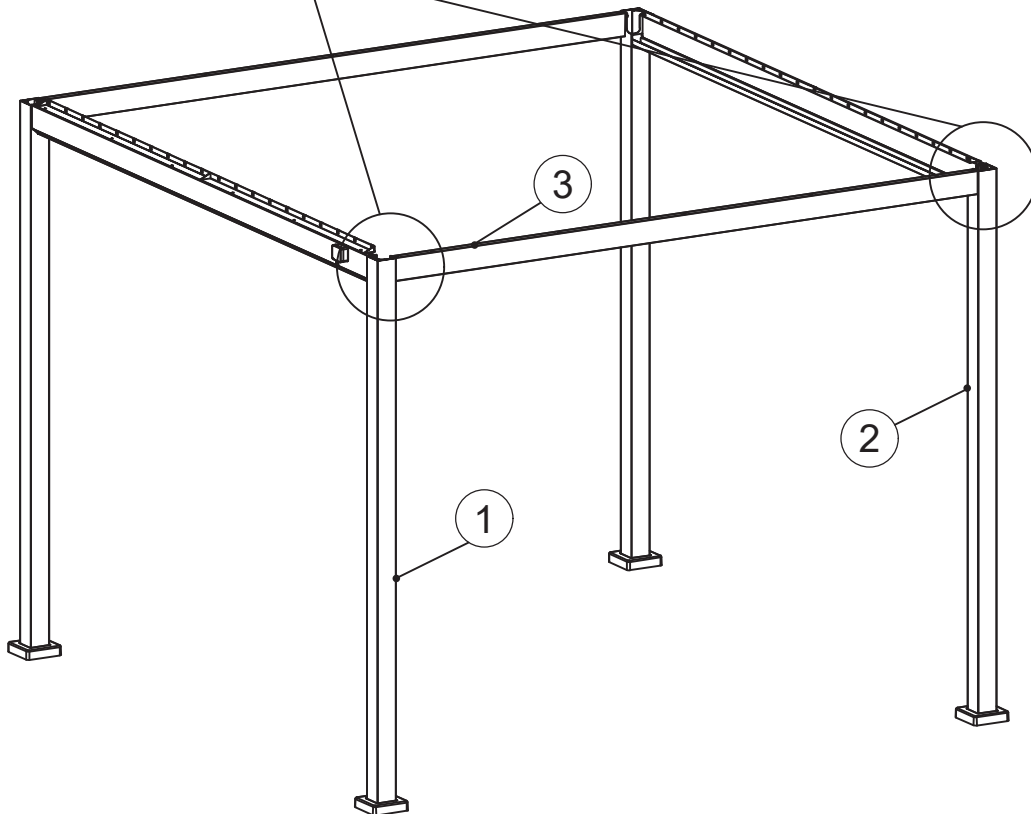
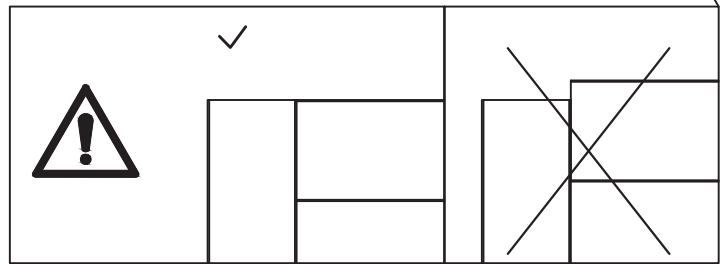
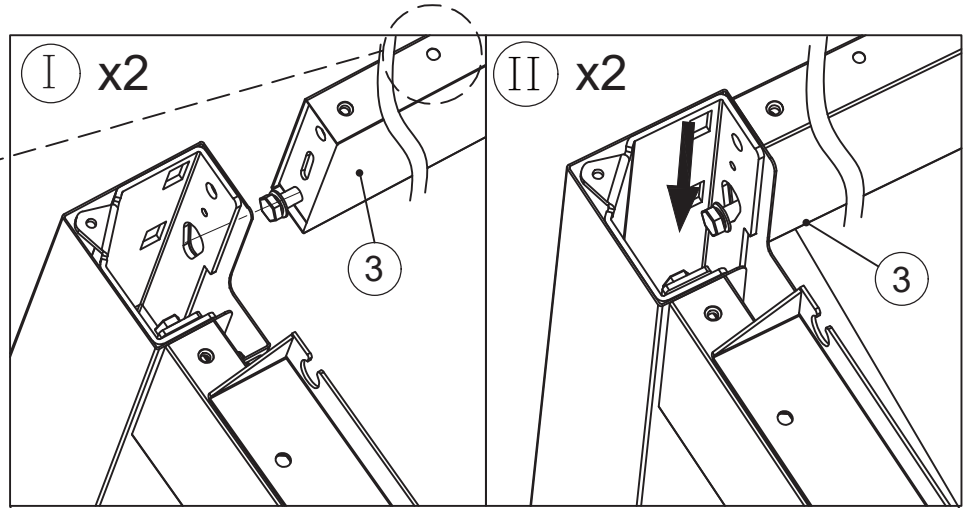
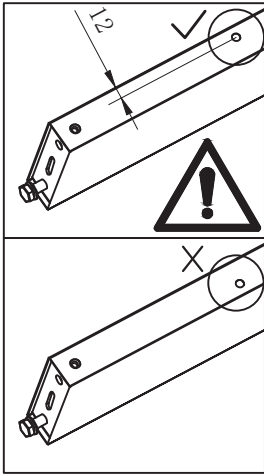
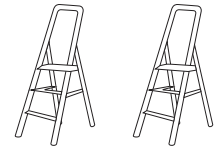

12

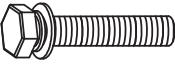

13

D x 2  M8 x 25 mm	M x 2  13 mm
--	---

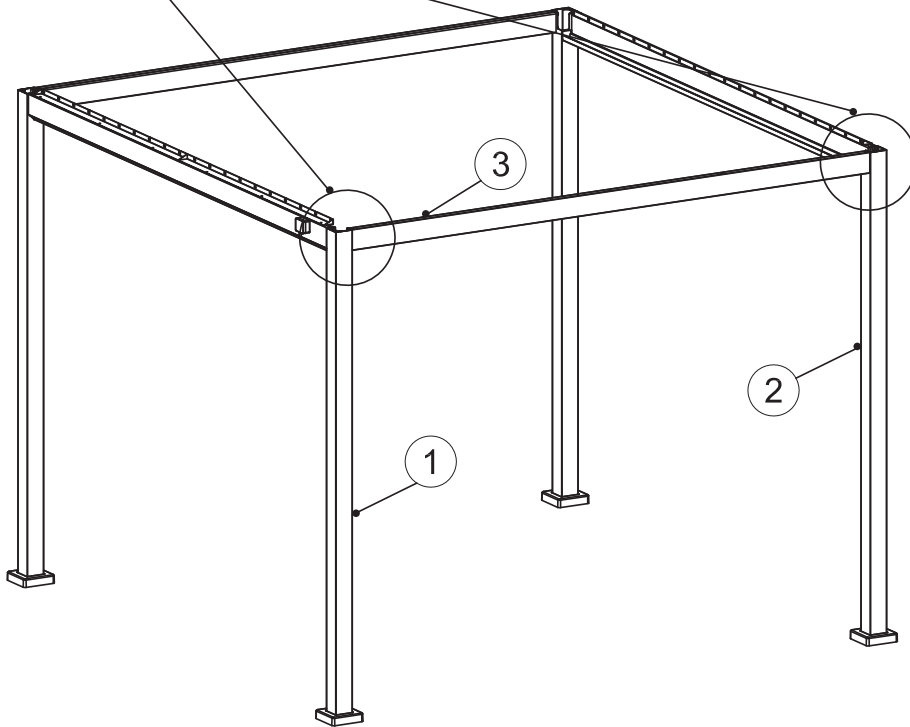
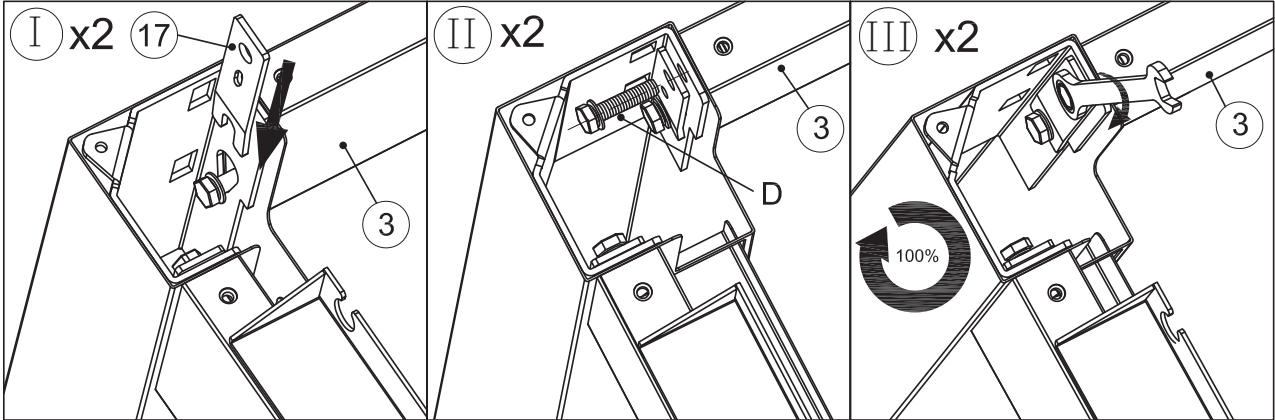
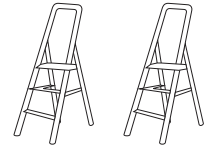

14

A x 12
M6 x 10 mm

K x 2
4 mm

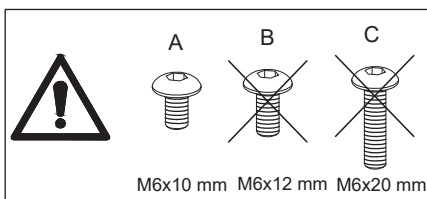
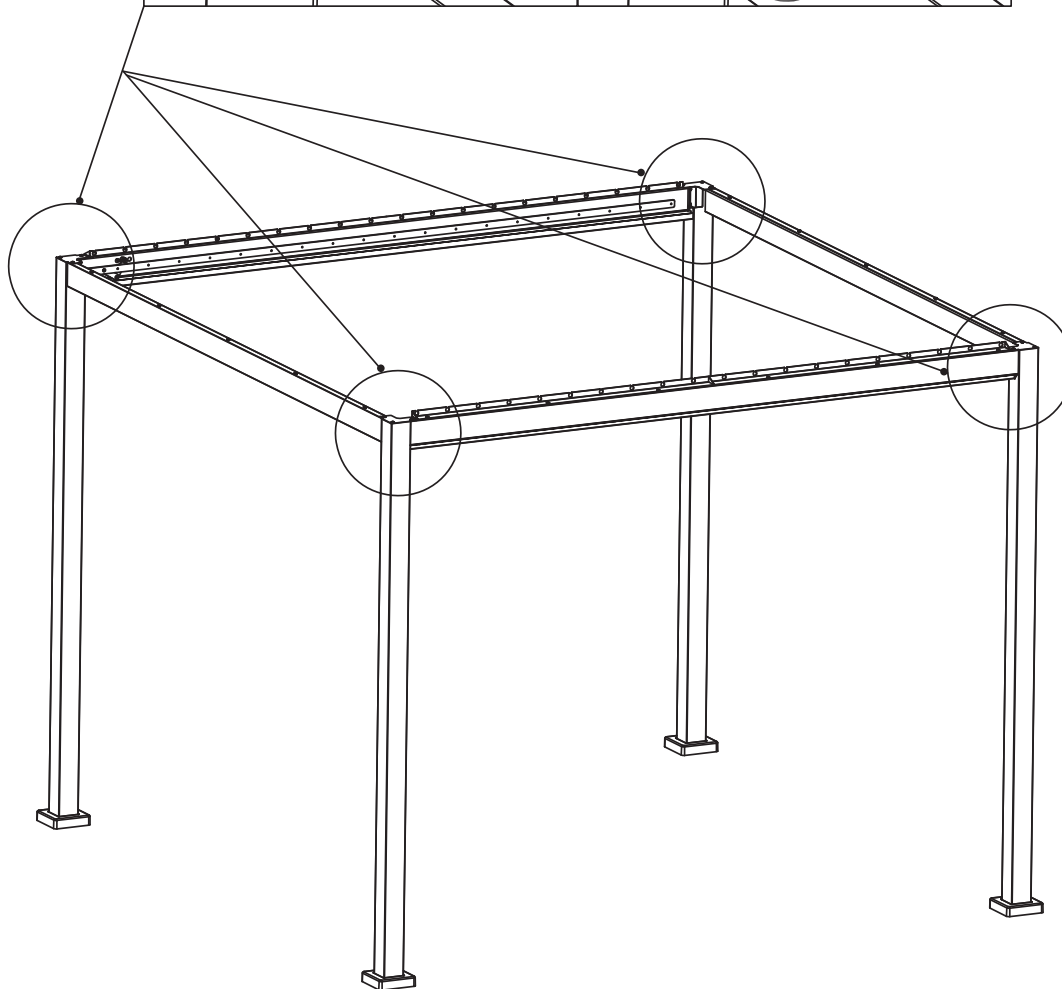
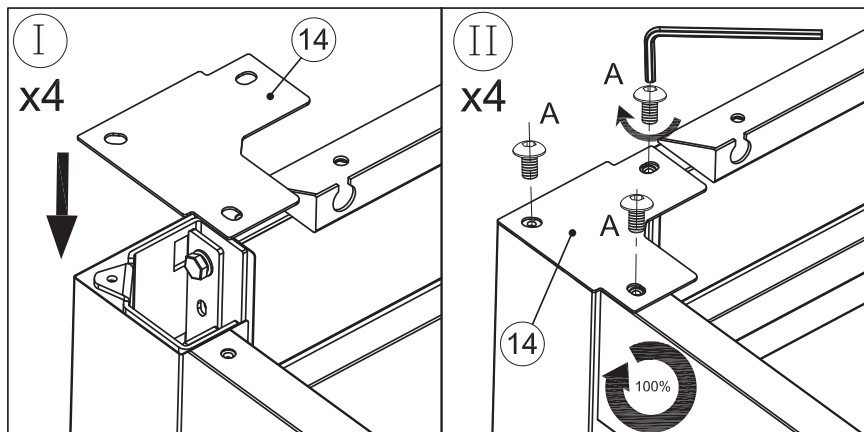
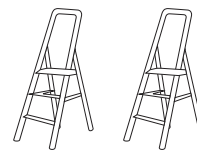

15

J x 1



Ø10 x 160 mm

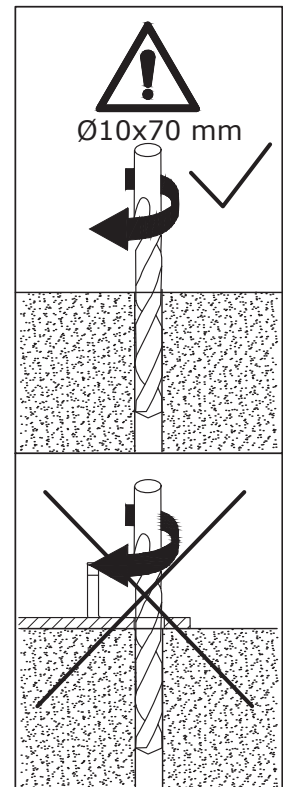
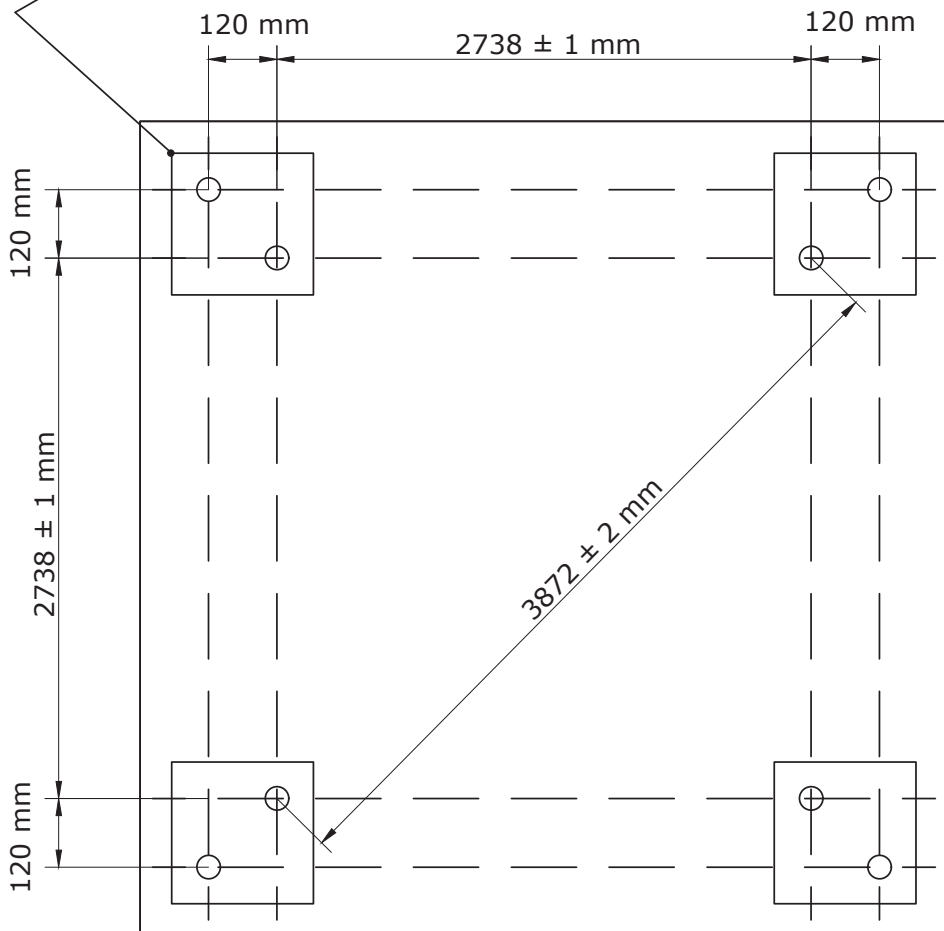
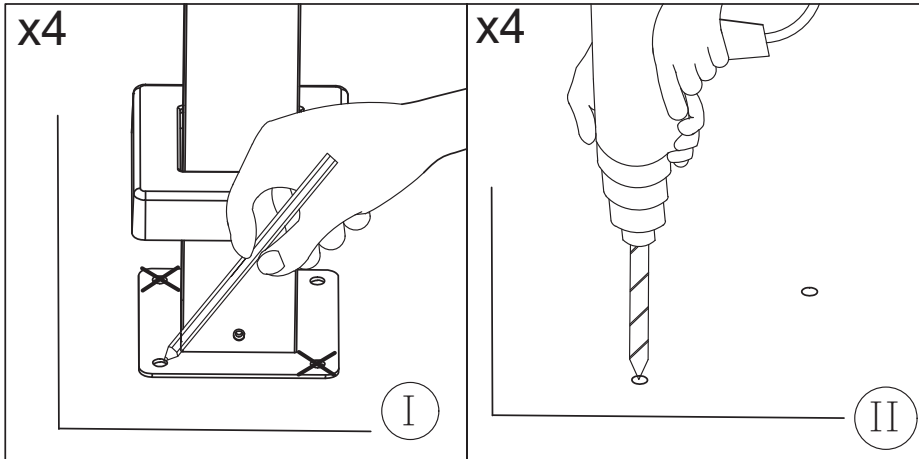

16

B x 40
M6 x 12 mm

K x 2
4 mm

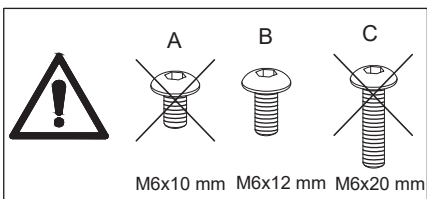
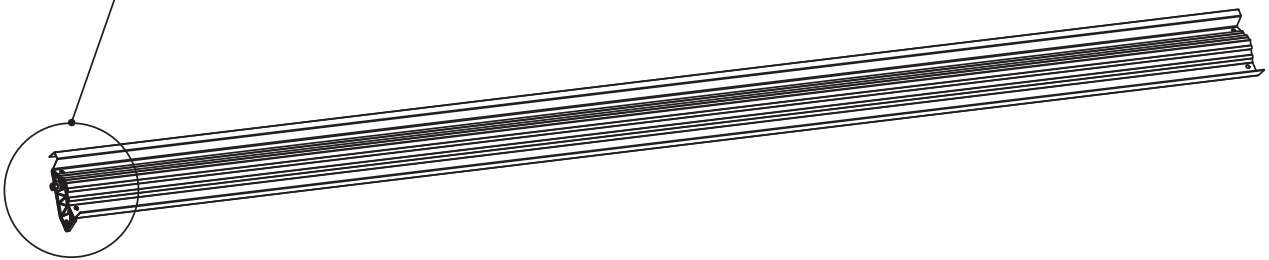
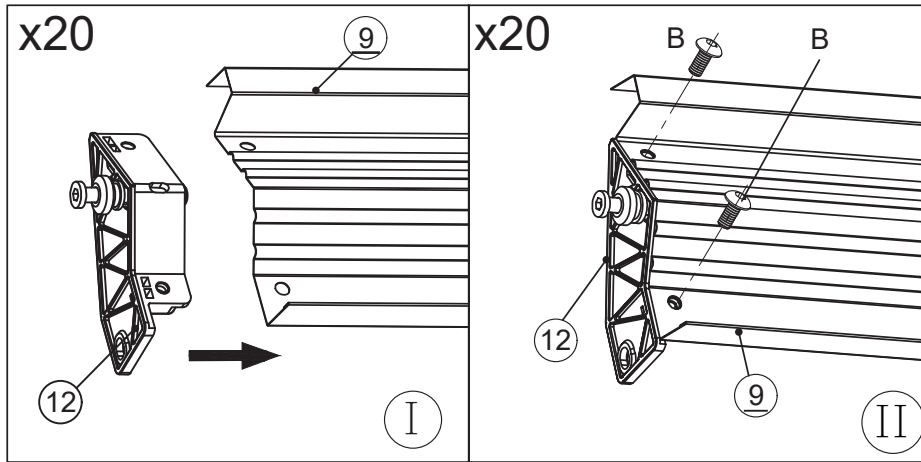

17

B x 40
M6 x 12 mm

K x 2
4 mm

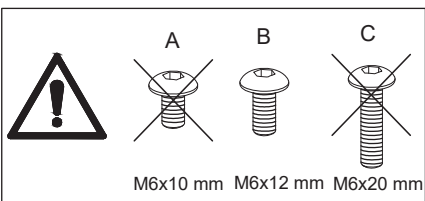
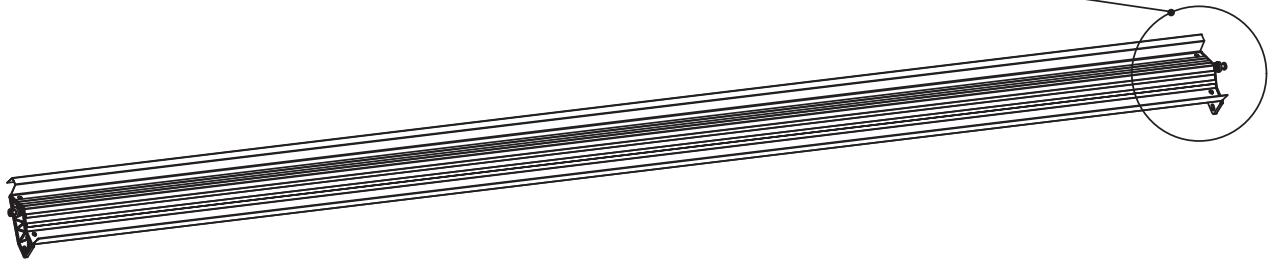
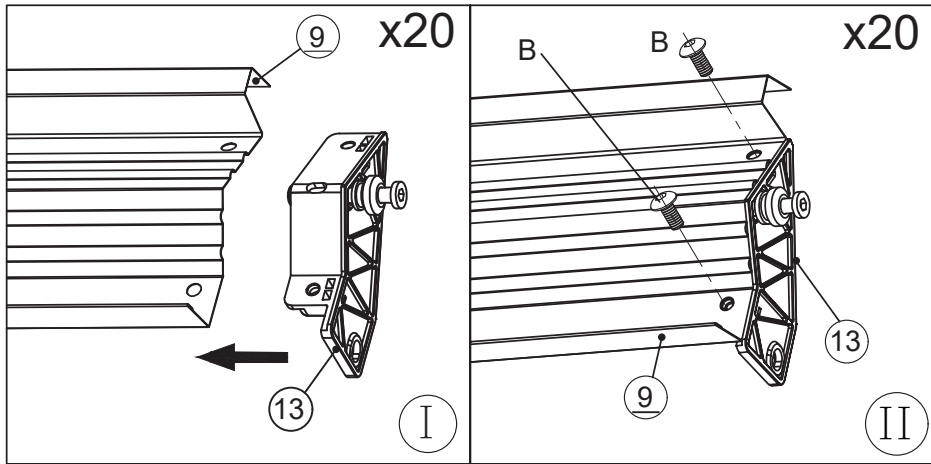

18

G x 2



Ø12.7/Ø17 mm

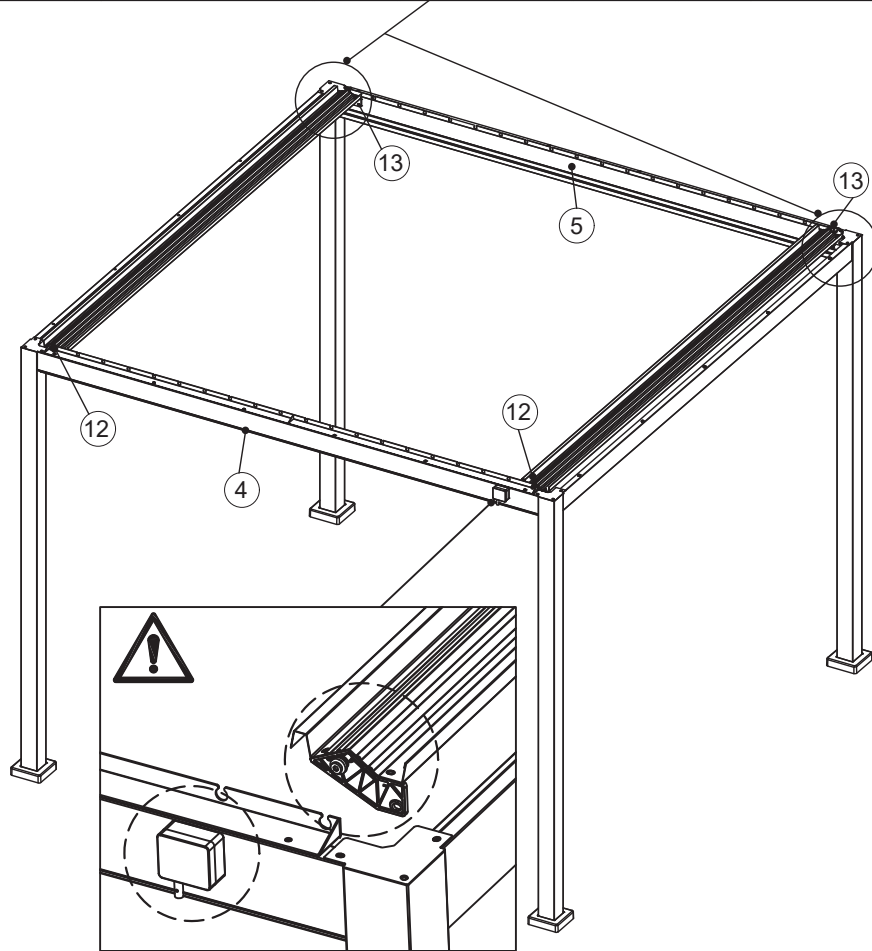
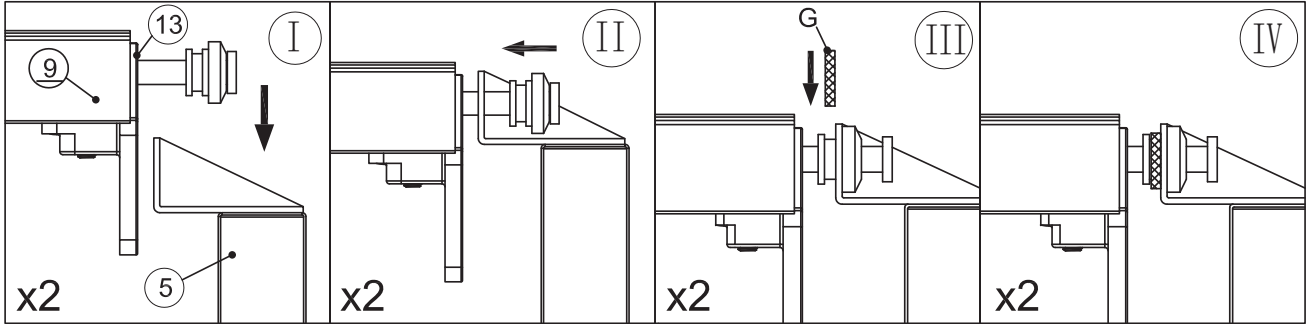
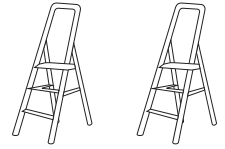

19

G x 2



Ø12.7/Ø17 mm

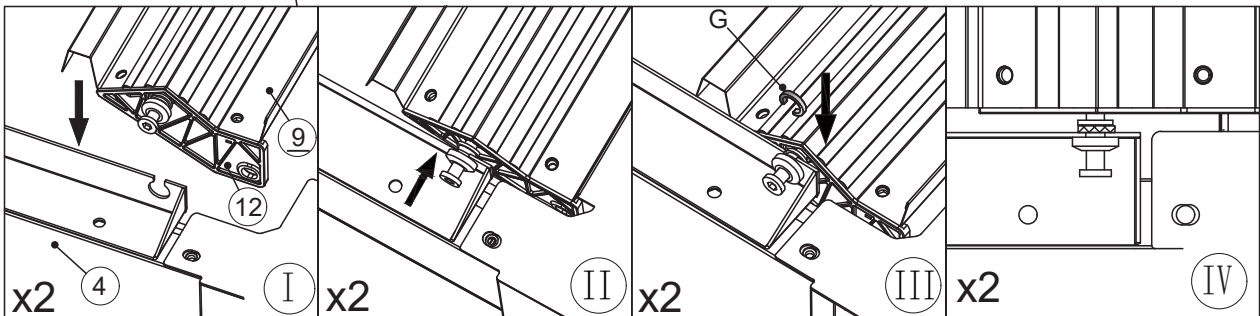
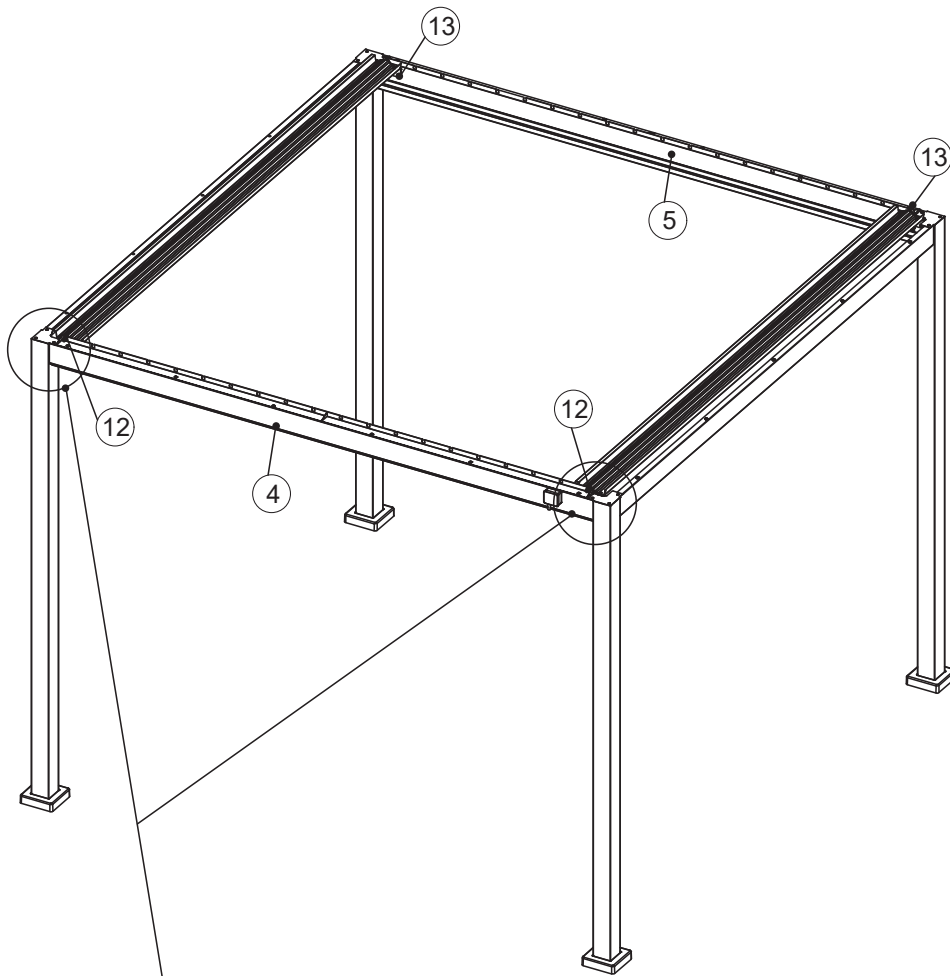
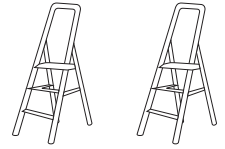

20



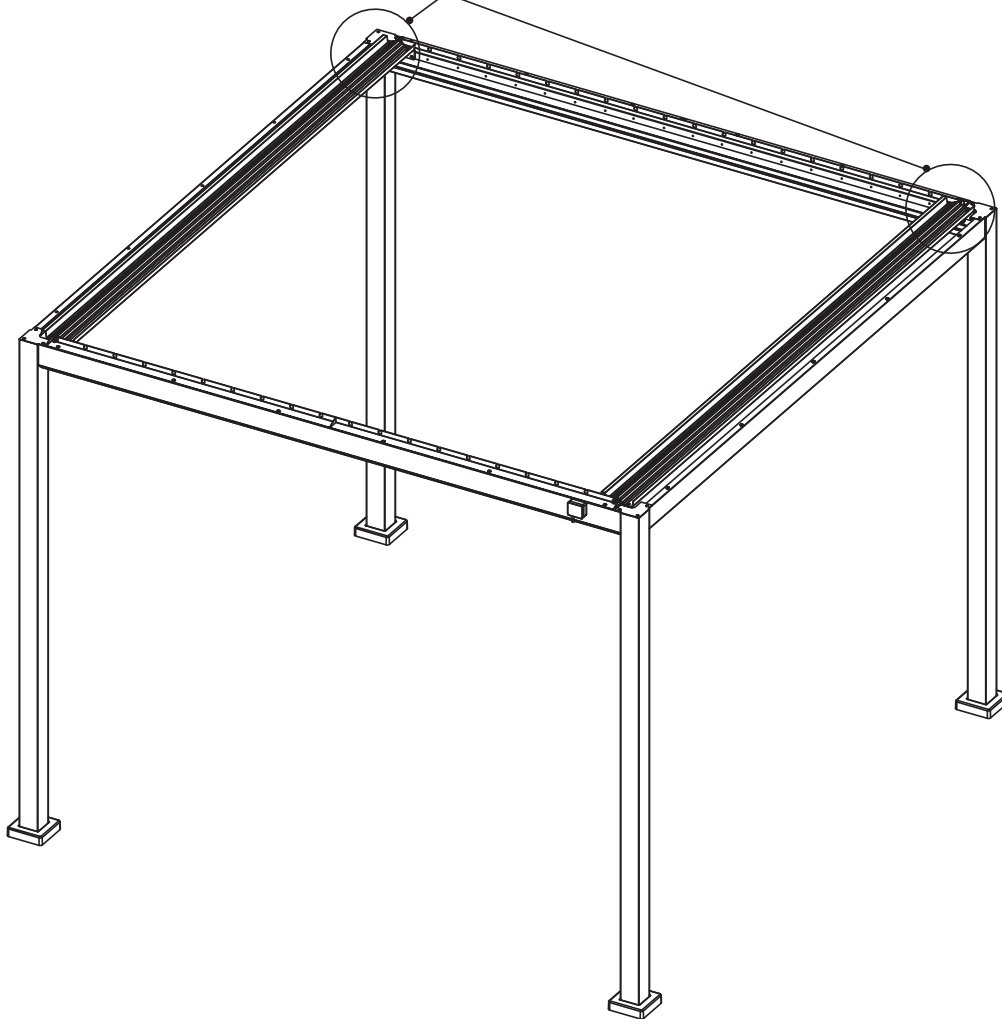
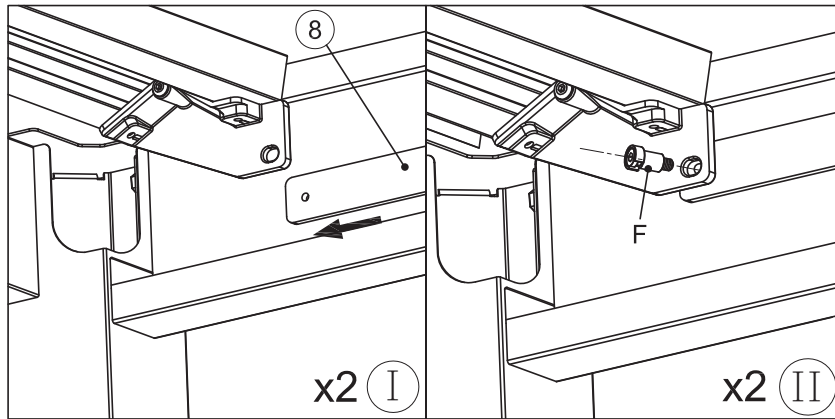
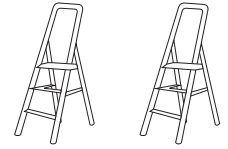

F x 2

Ø12 x 23 mm

K x 2

4 mm



21

<p>F x 2</p>  <p>Ø12 x 23 mm</p>	<p>K x 2</p>   <p>4 mm</p>	 
---	---	---

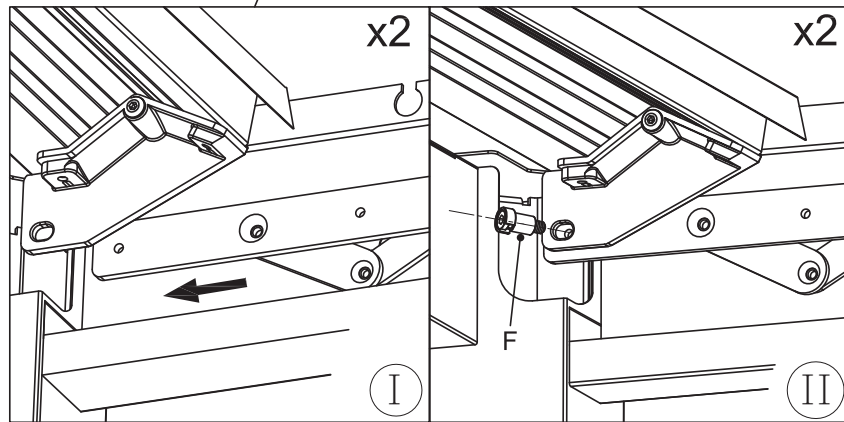
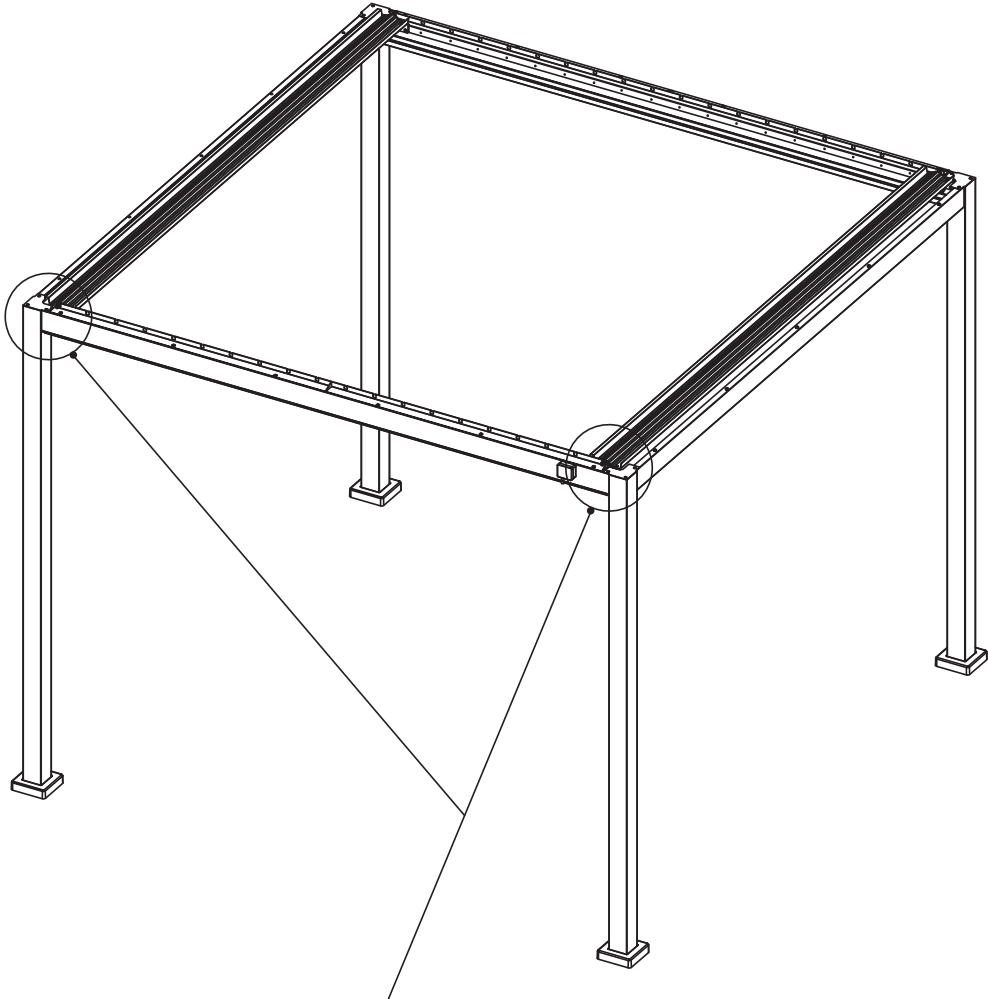

22

G x 1



Ø12.7/Ø17 mm

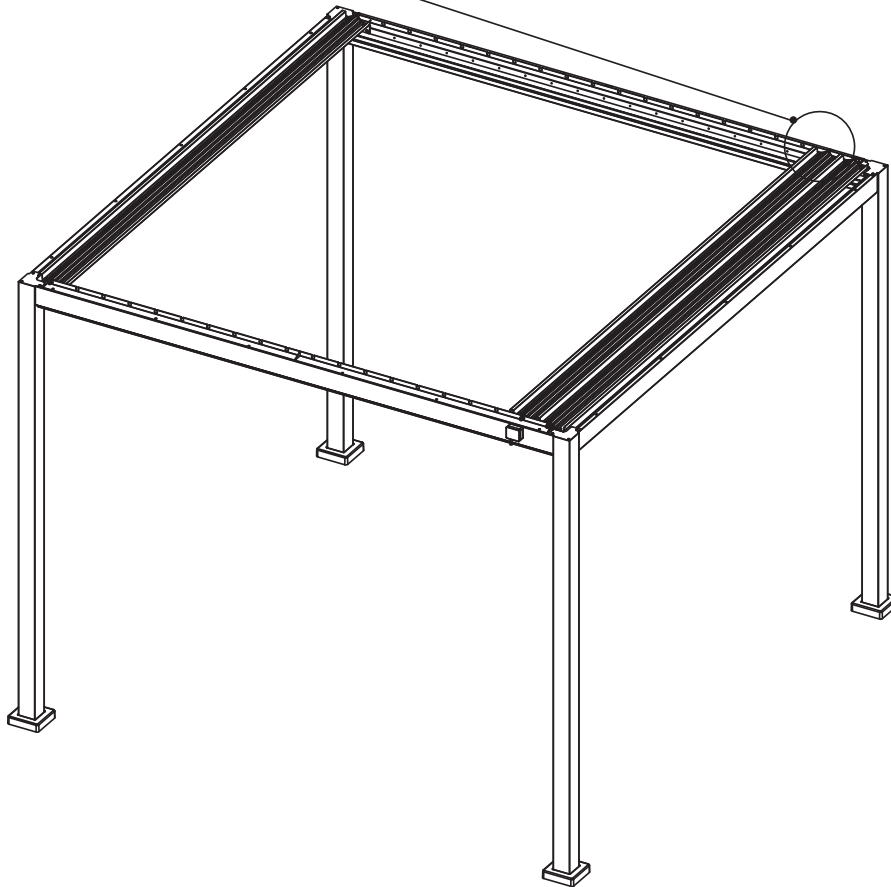
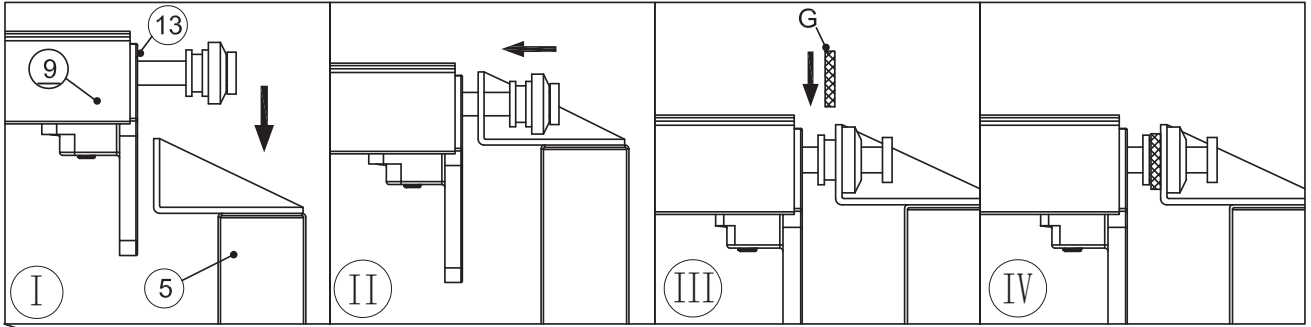
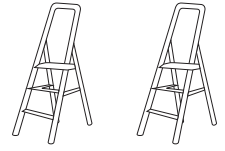

23

G x 1



Ø12.7/Ø17 mm

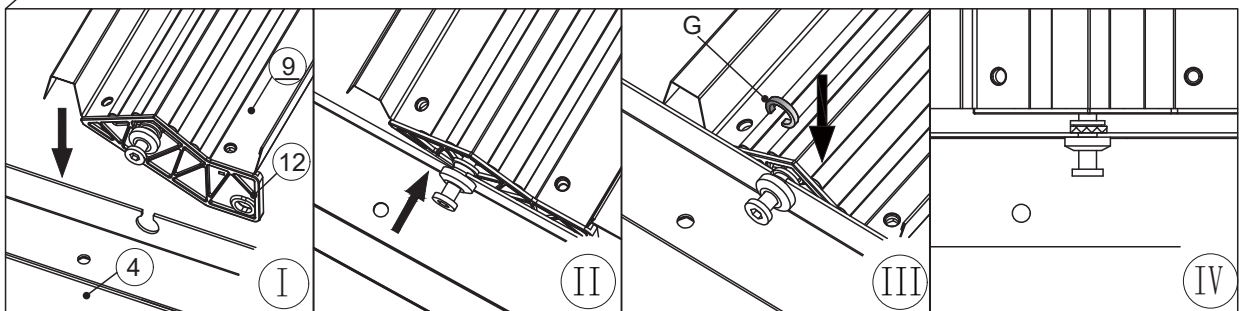
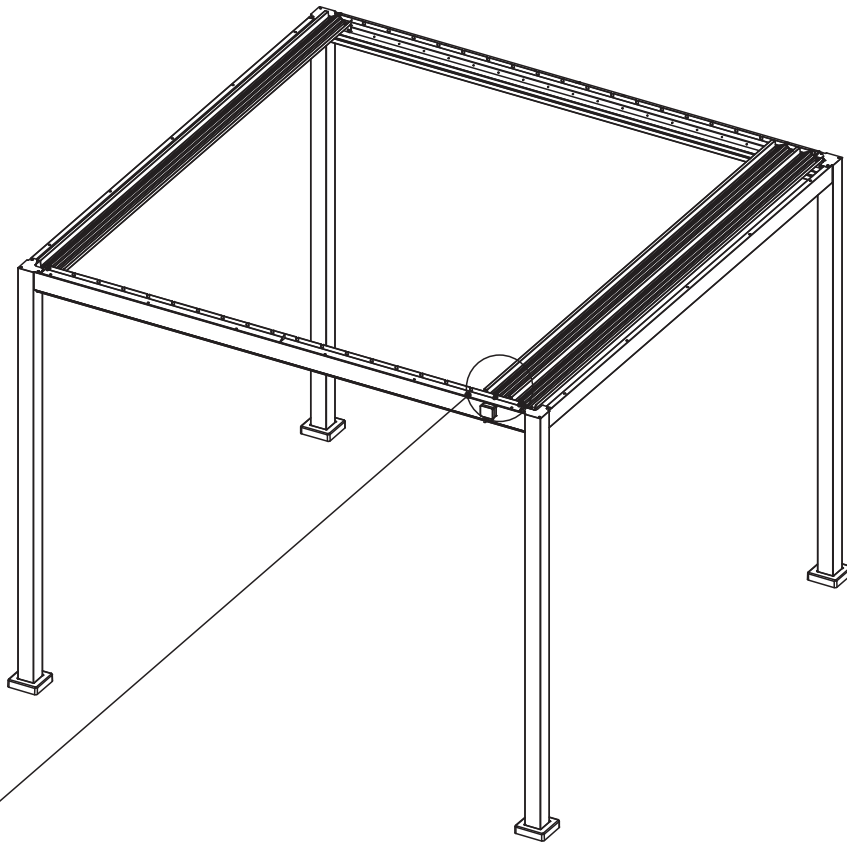
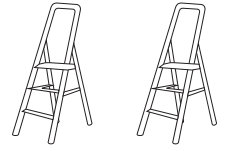

24

<p>F x 1</p>  <p>Ø12 x 23 mm</p>	<p>K x 2</p>   <p>4 mm</p>	 
---	---	---

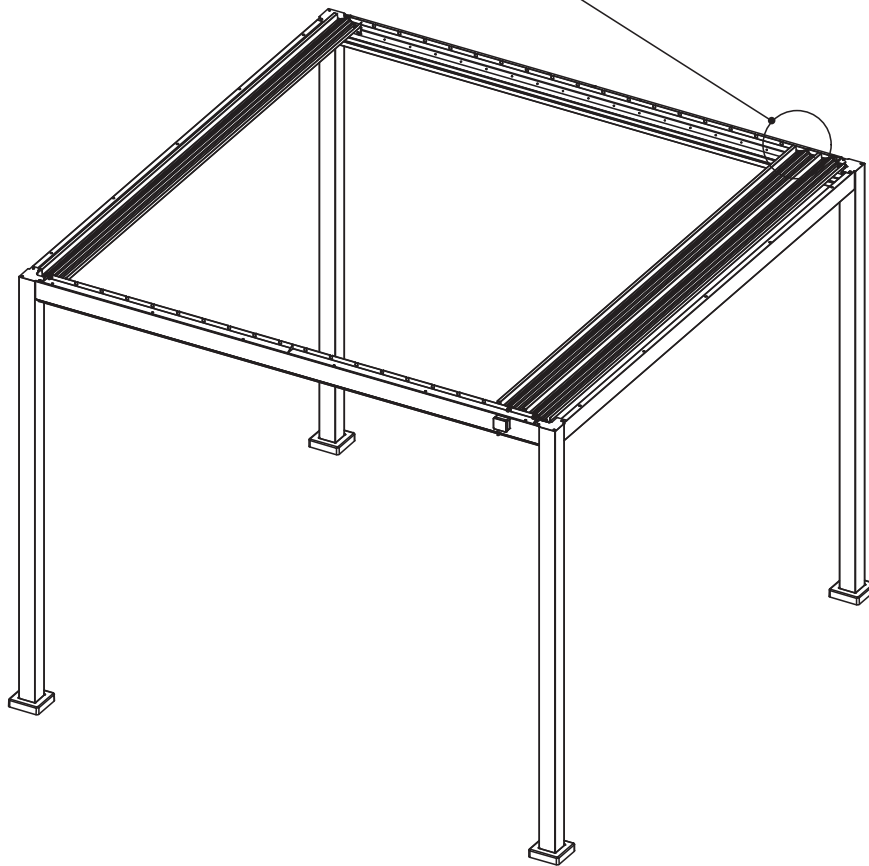
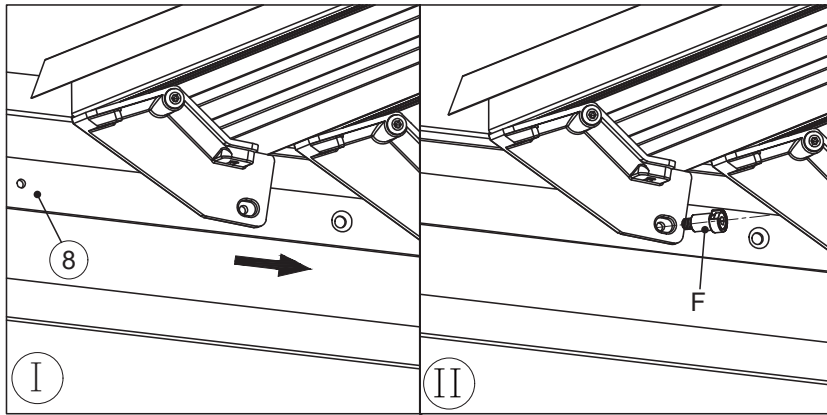

25

F x 1



Ø12 x 23 mm

K x 2



4 mm

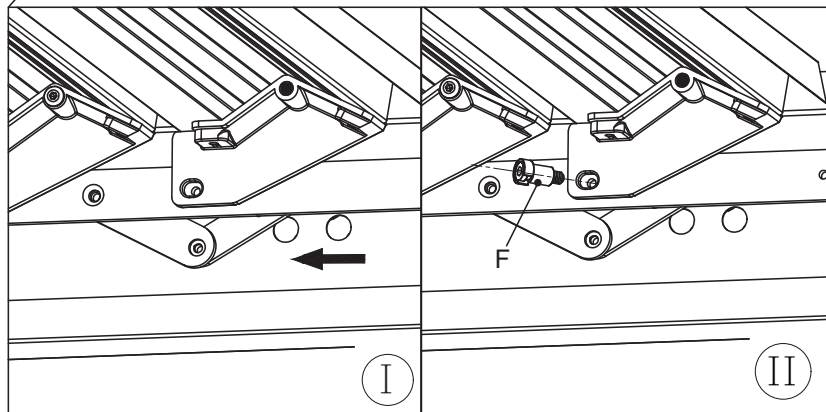
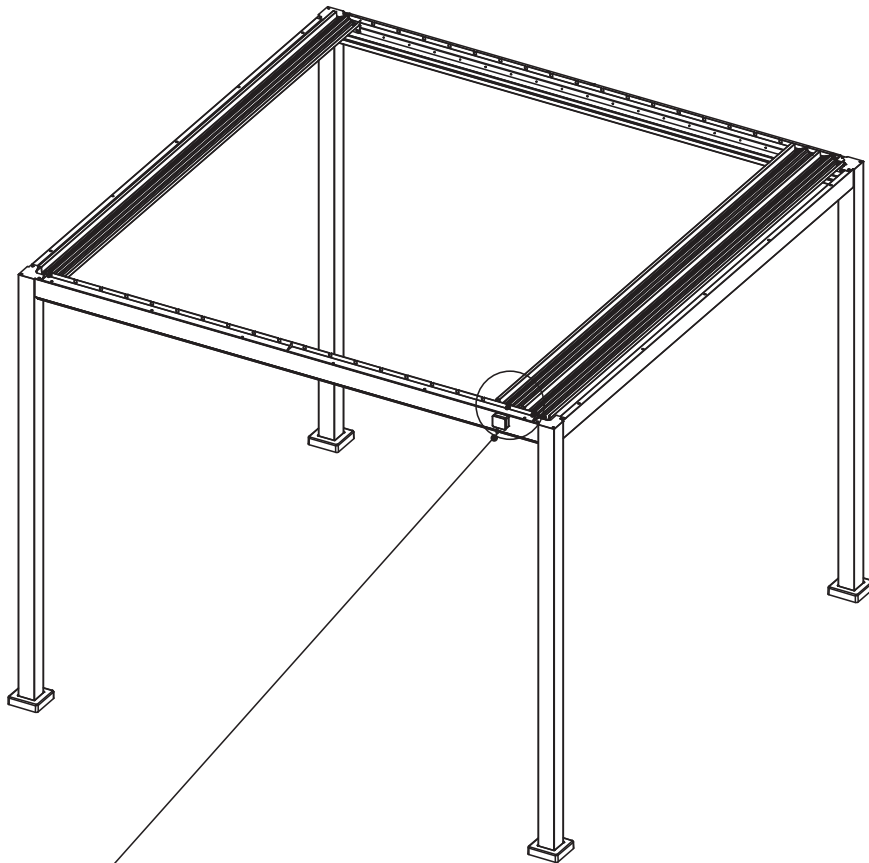
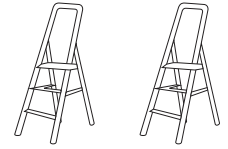

26

G x 17



Ø12.7/Ø17 mm

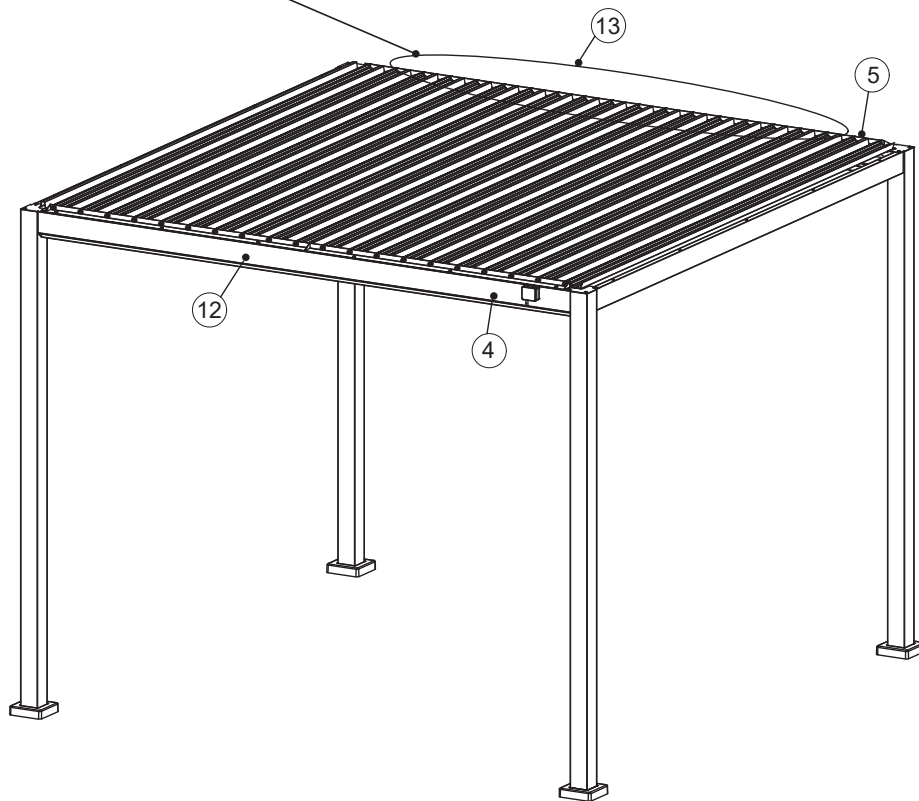
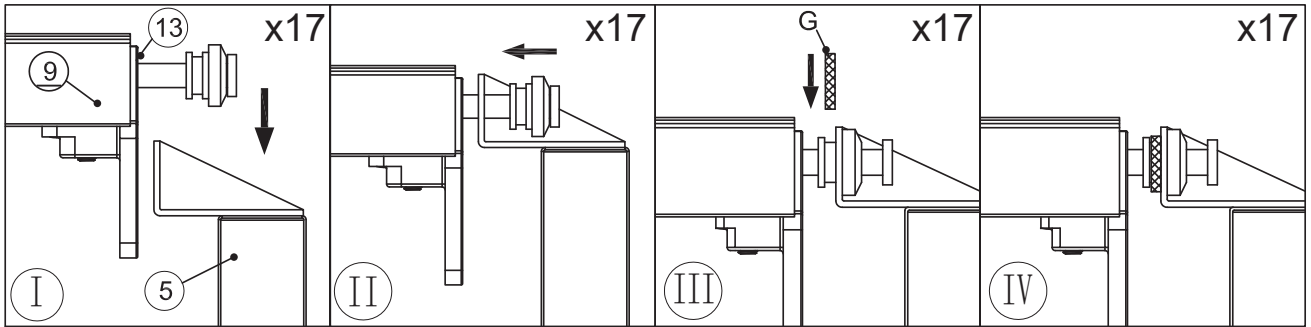
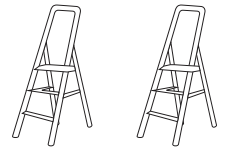

27

G x 17



Ø12.7/Ø17 mm

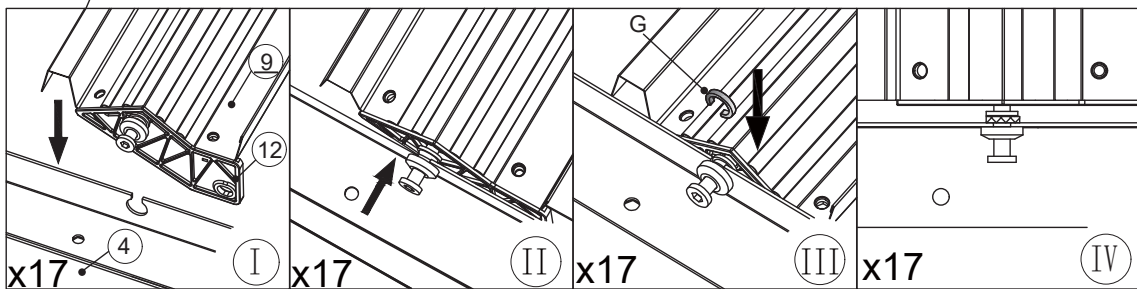
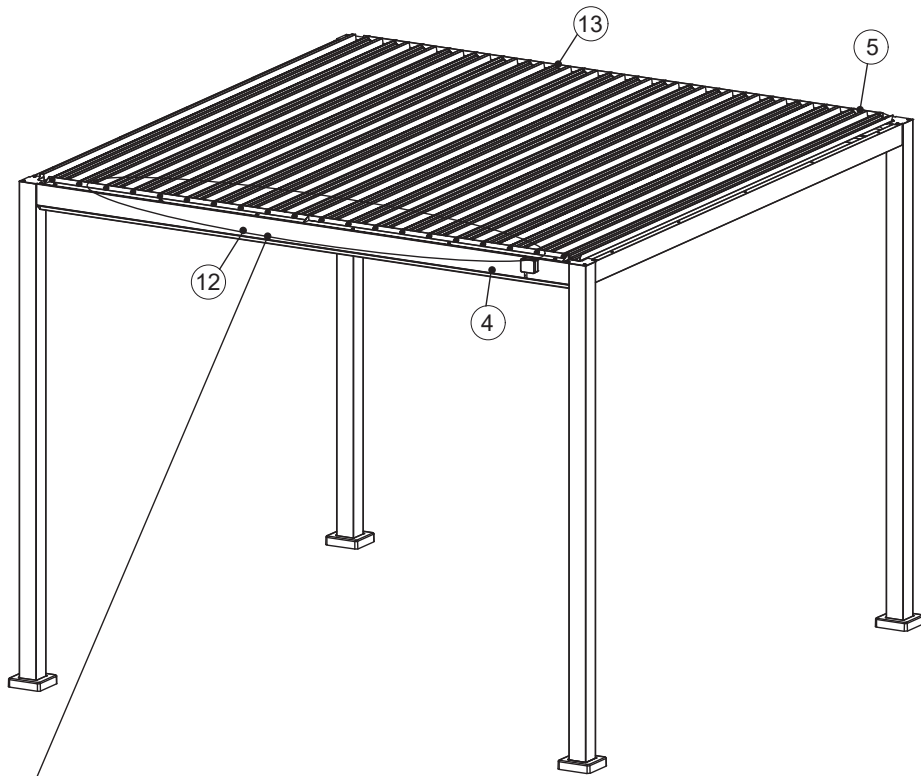
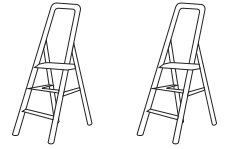

28

F x 17

Ø12 x 23 mm

K x 2

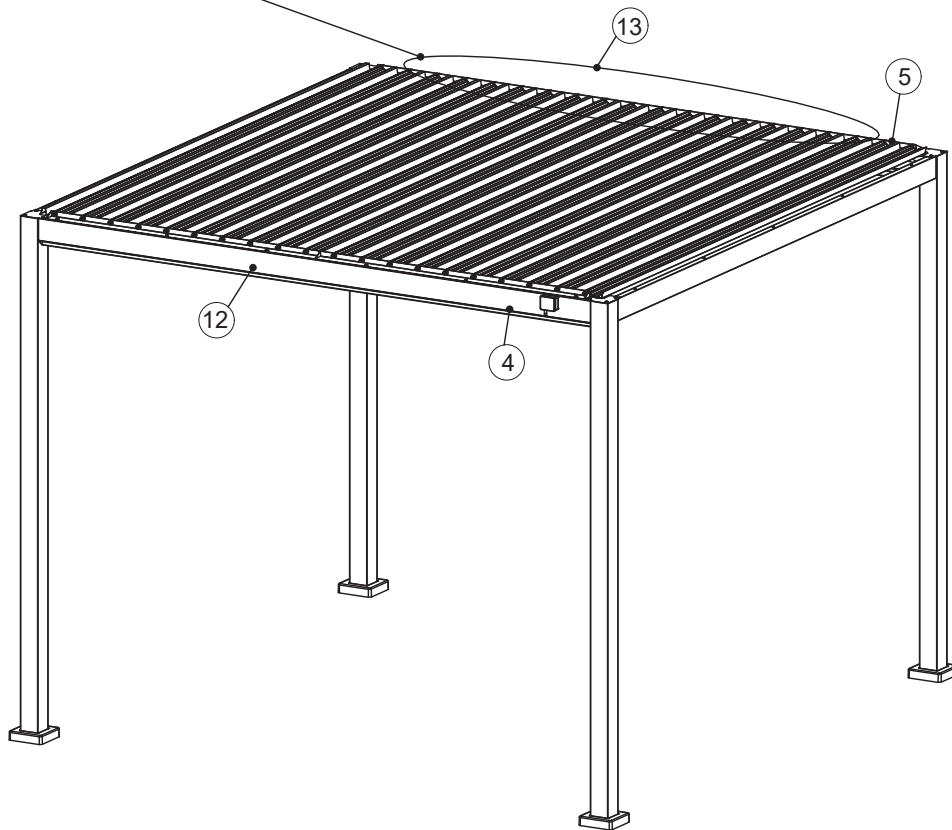
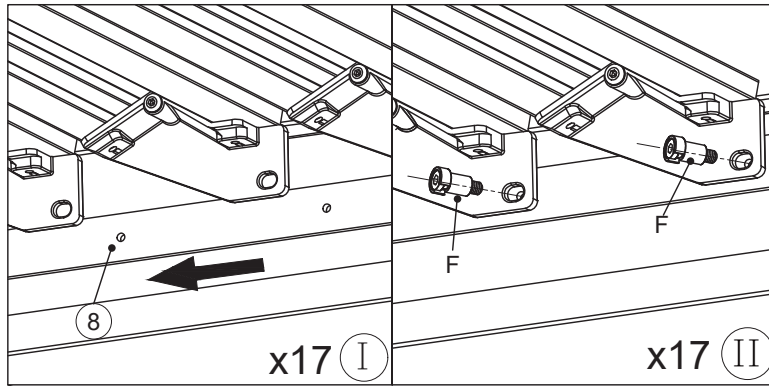
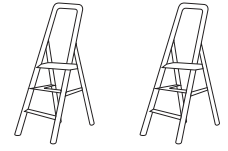
4 mm



29



F x 17

Ø12 x 23 mm

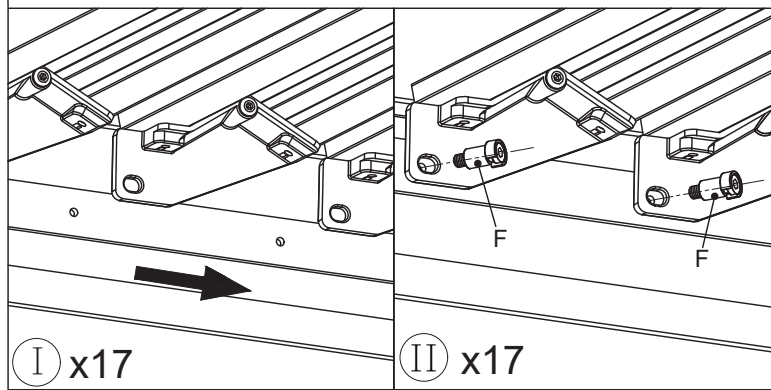
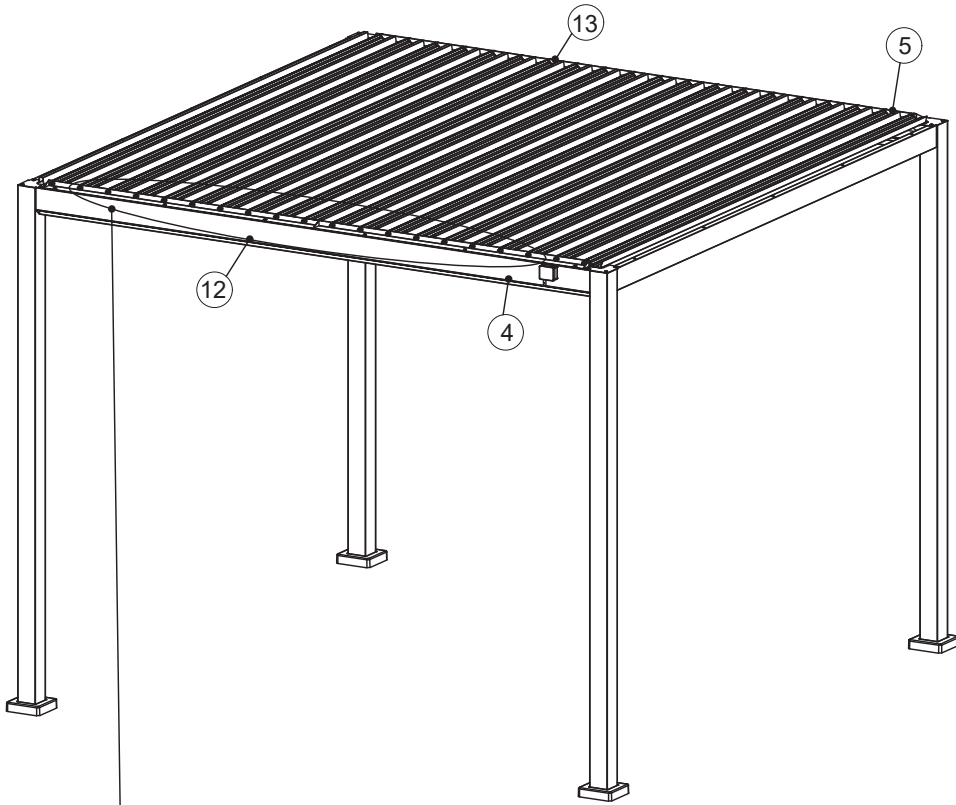
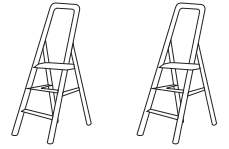
K x 2

4 mm

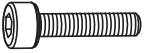

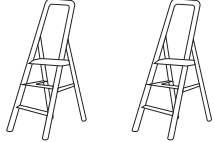
30

<p>E x 1</p>  <p>M5 x 20 mm</p>	<p>K x 2</p>  <p>4 mm</p>	
--	--	---

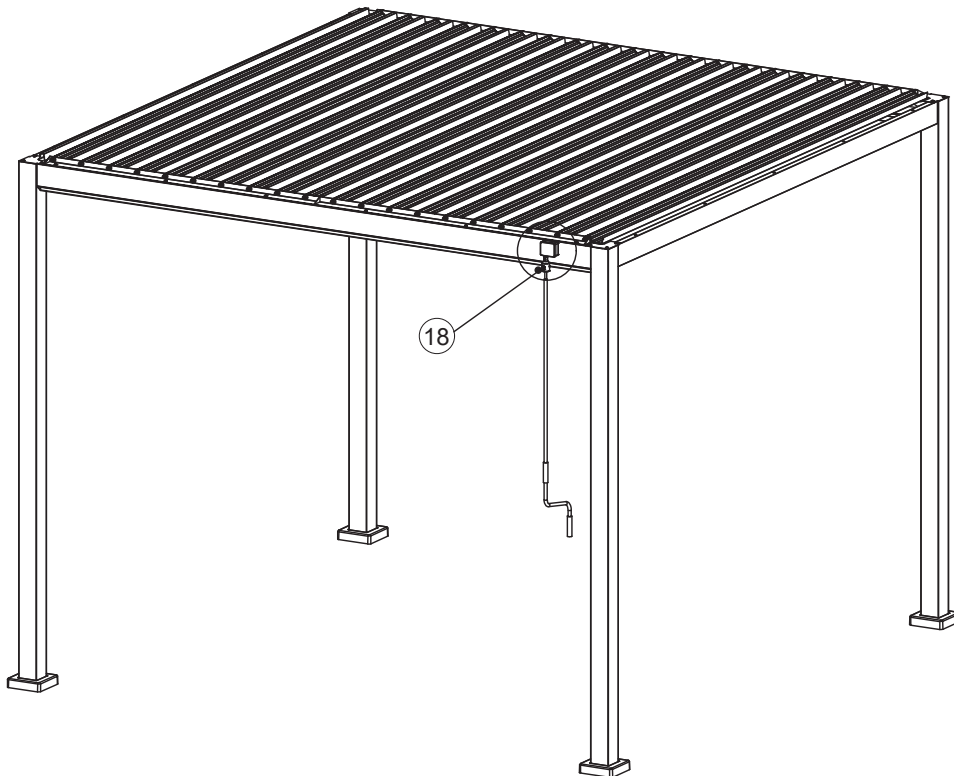
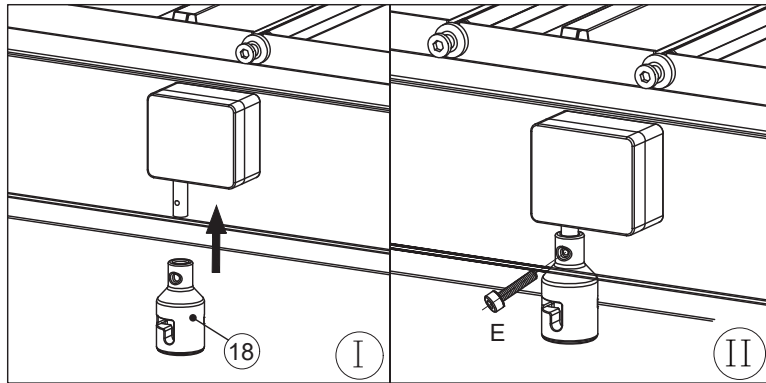

31

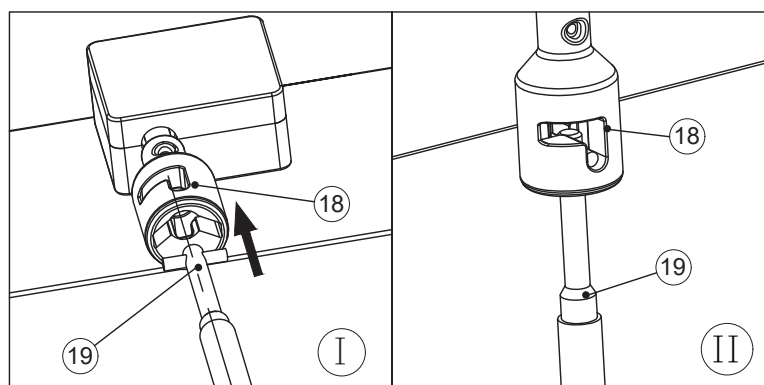
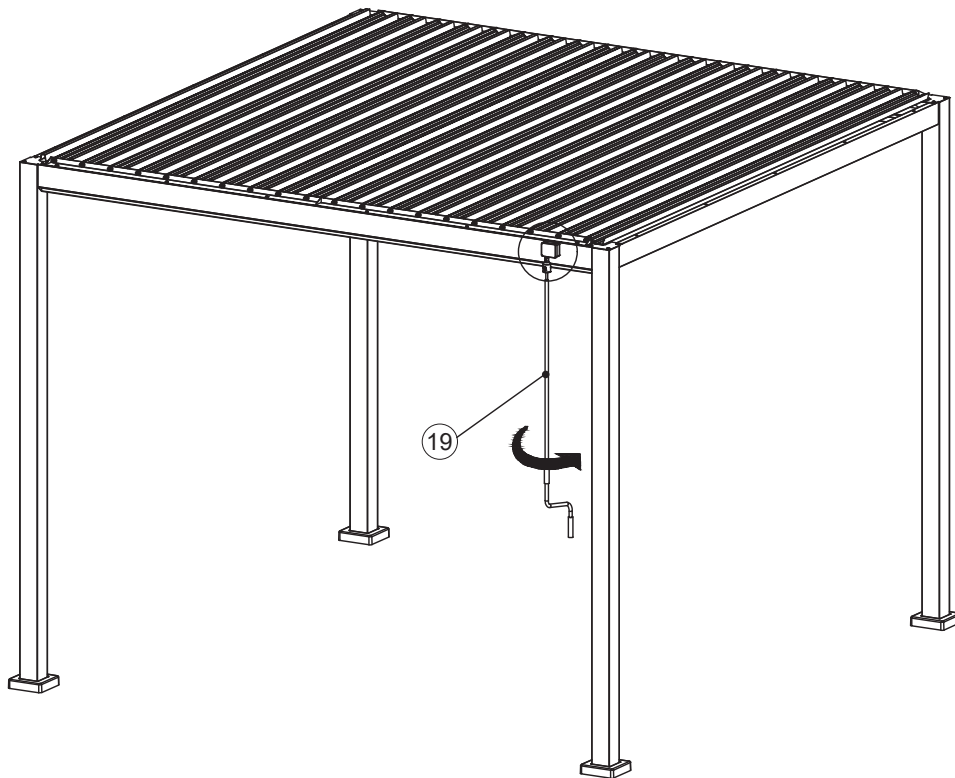

32

C x 5
M6 x 20 mm

K x 2
4 mm

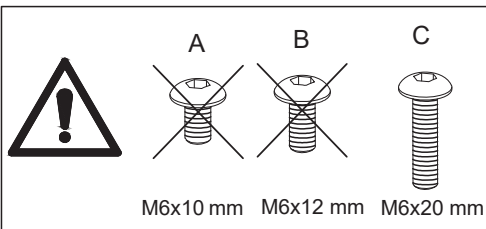
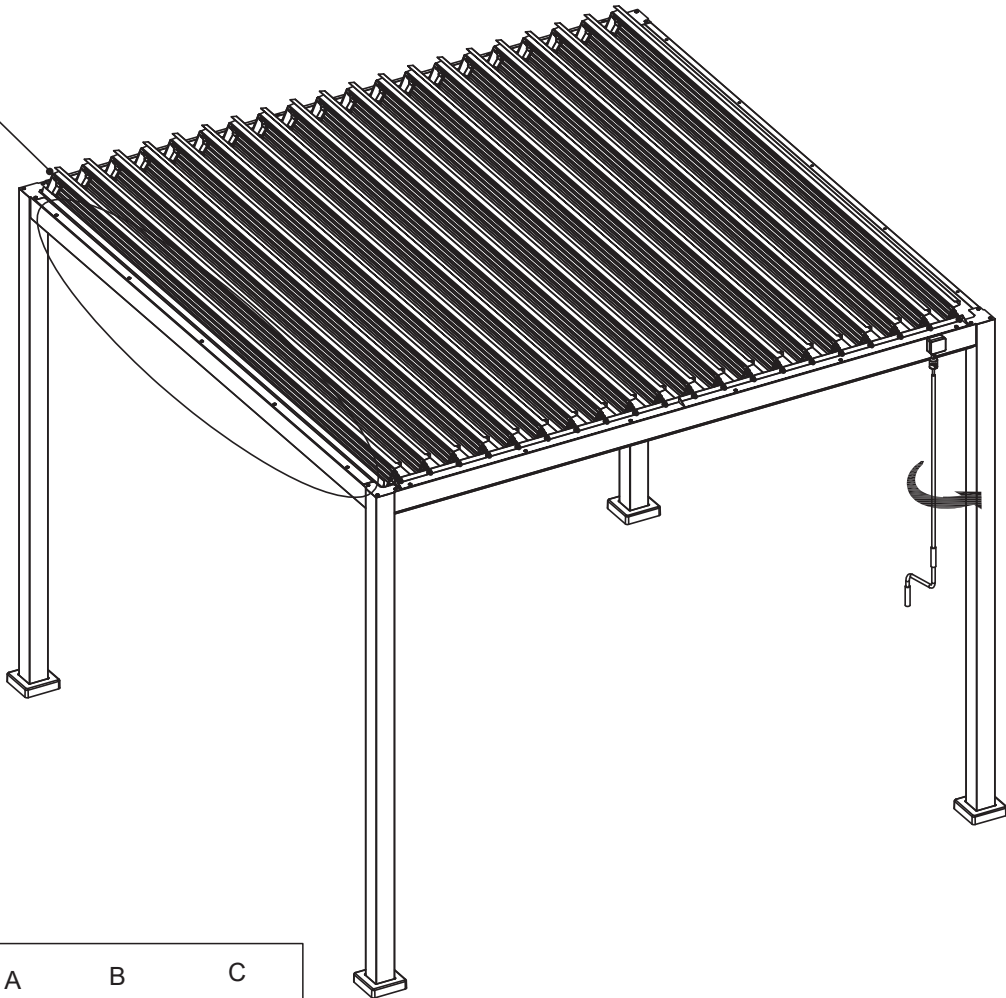
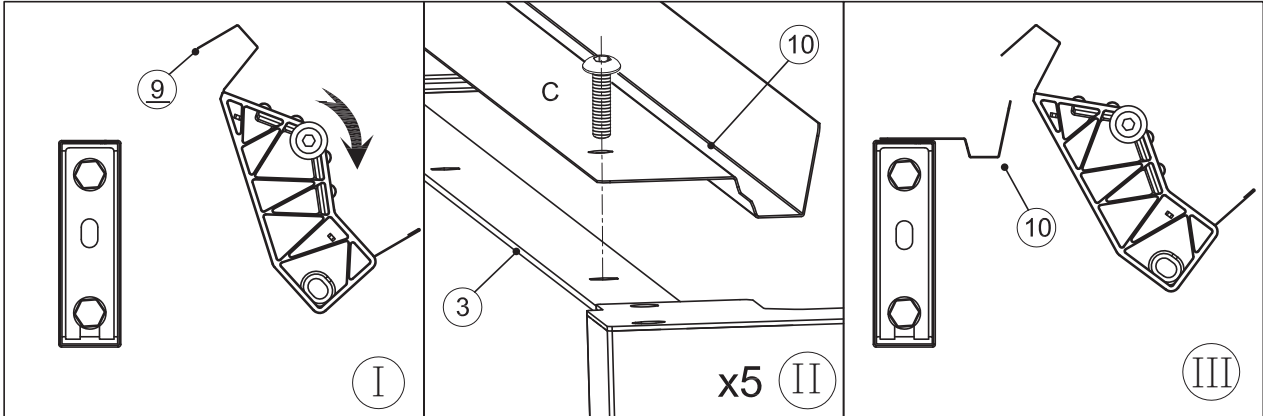
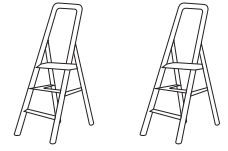

33

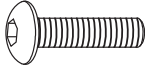

C x 5
M6 x 20 mm

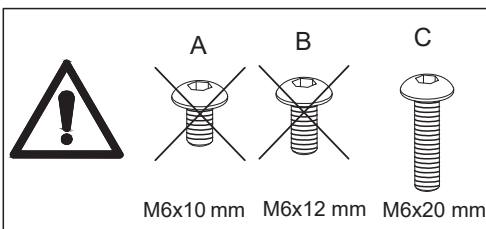
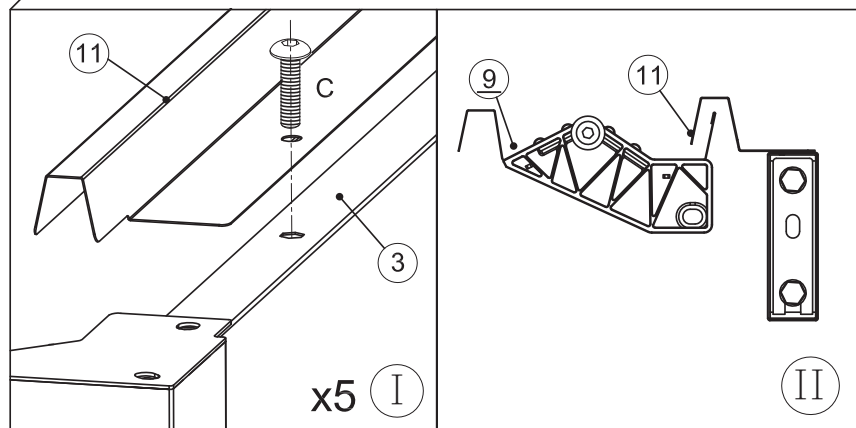
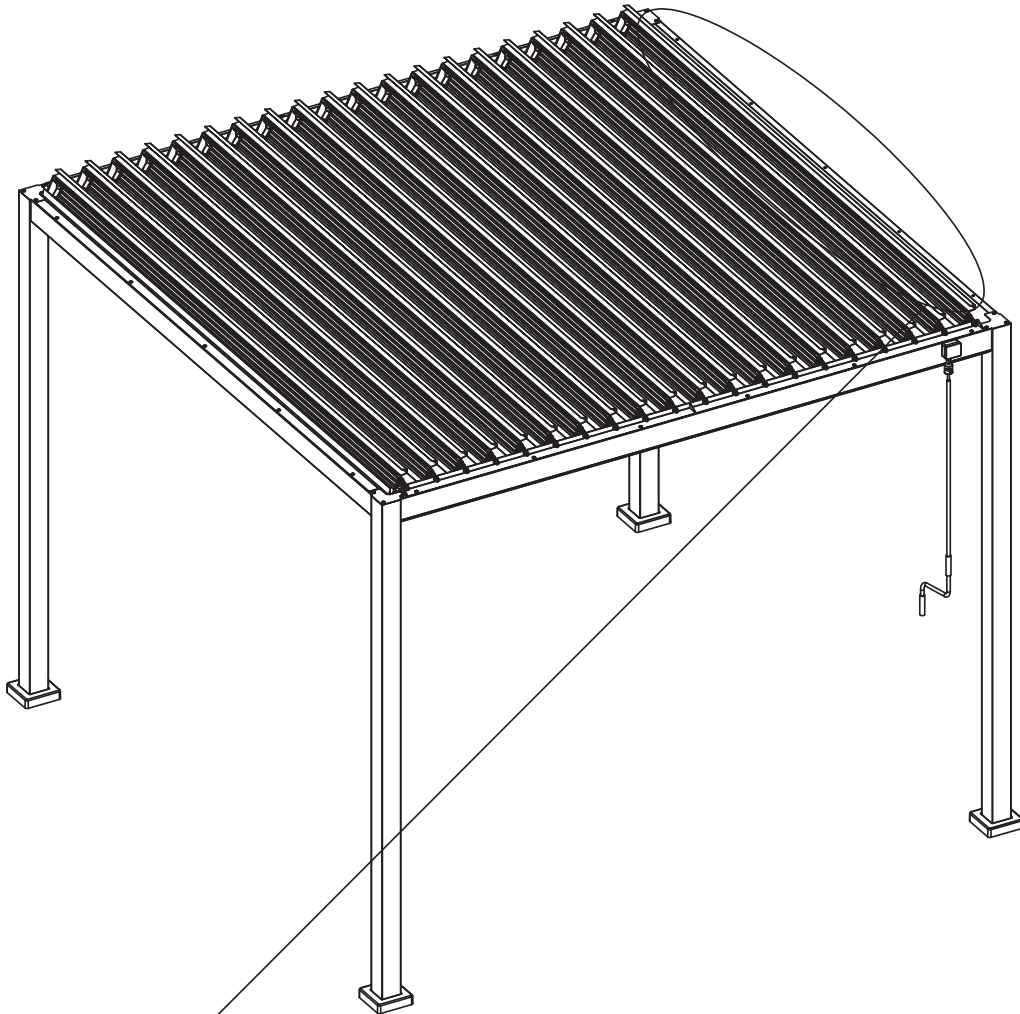
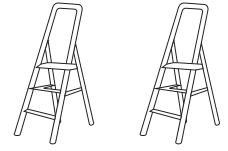
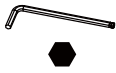

K x 2
4 mm

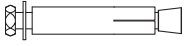

34

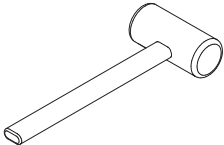
H x 8  M6 x 60 mm	L x 2  10 mm	
--	---	---

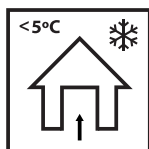
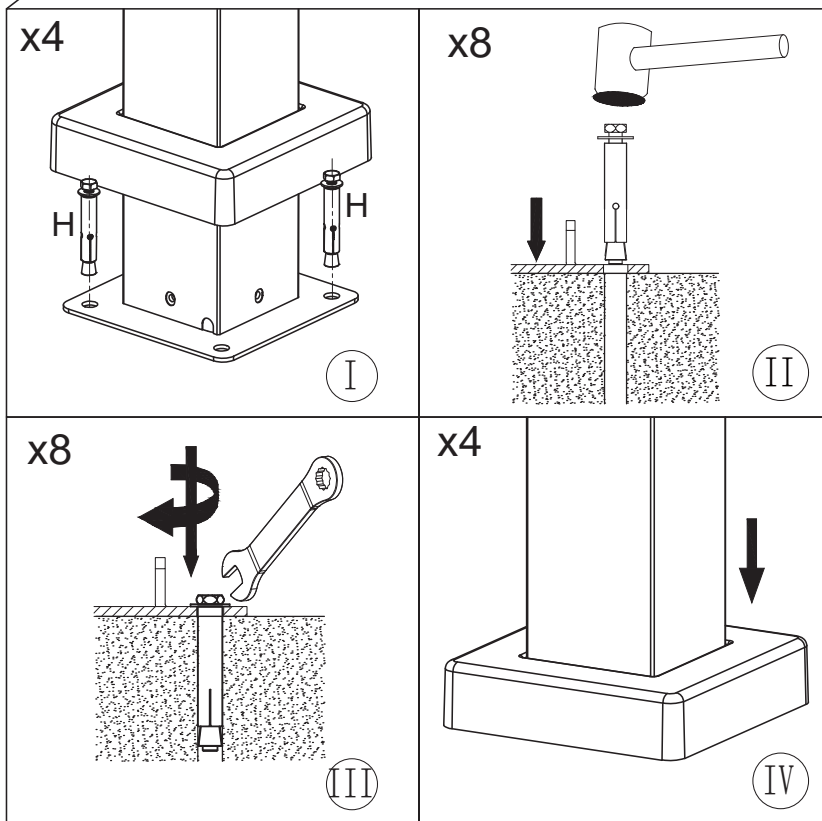
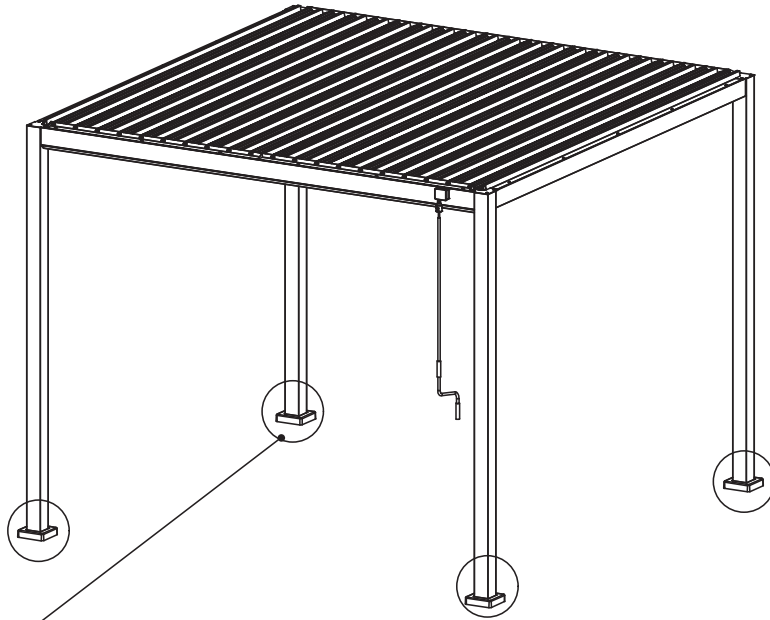

SIA "Do It",
Biķeru
iela 4, Ulbroka,
Stopiņu pagasts,
Ropažu novads,
LV-2130, Latvija;
info@doit.lv